

"Wireless World"  
Iliffe Electrical Publications Ltd.,  
Dorset House, Stamford Street,  
London, S.E.1

*Managing Director:*

W. E. MILLER, M.A., M.I.E.R.E.

*Editor-in-Chief:*

W. T. COCKING, M.I.E.E.

*Editor:*

H. W. BARNARD

*Technical Editor:*

T. E. IVALL

*Editorial:*

D. C. ROLFE

G. B. SHORTER, B.Sc.

*Drawing Office:*

H. J. COOKE

*Production:*

D. R. BRAY

*Advertisements:*

G. BENTON ROWELL

(Manager)

J. R. EYTON-JONES

© Iliffe Electrical Publications Ltd., 1965. Permission in writing from the Editor must first be obtained before letterpress or illustrations are reproduced from this journal. Brief extracts or comments are allowed provided acknowledgement to the journal is given.

VOLUME 71 No. 10

PRICE: 3s.

FIFTY-FIFTH YEAR  
OF PUBLICATION

# Wireless World

ELECTRONICS, TELEVISION, RADIO, AUDIO

---

OCTOBER 1965

- 469 Editorial Comment  
470 Domestic Receiver Survey  
474 The Season's Sets  
483 A Non-resonant Loudspeaker Enclosure Design *by A. R. Bailey*  
487 World of Wireless  
489 Personalities  
491 News from Industry  
493 Letters to the Editor  
495 German Radio Show  
499 Radio and TV in East Germany  
501 Paris Radio Show  
503 Slow-motion Television *by M. Leeuwin*  
507 R.E.M.E. School of Electronics  
509 INEL 65  
511 October Meetings  
513 Electronic Laboratory Instrument Practice—10 *by T. D. Towers*  
518 Economical Logic *by H. R. Henly*  
524 Keeping the Radio Peace  
525 Books Received  
526 New Products  
532 Real and Imaginary *by "Vector"*  
534 Commercial Literature  
534 H.F. Predictions—October
- 

PUBLISHED MONTHLY (4th Monday of preceding month). Telephone: Waterloo 3333 (70 lines). Telegrams/Telex: Wiworld Iliffepres 25137 London. Cables: "Ethaworld, London, S.E.1." Annual Subscriptions: Home £2 6s 0d. Overseas: £2 15s 0d. Canada and U.S.A. \$8.00. Second-class mail privileges authorised at New York N.Y. BRANCH OFFICES: BIRMINGHAM: King Edward House, New Street, 2. Telephone: Midland 7191. BRISTOL: 11, Marsh Street, 1. Telephone: Bristol 21491/2. COVENTRY: 8-10, Corporation Street, Telephone: Coventry 25210. GLASGOW: 123, Hope Street, C.2. Telephone: Central 1265-6. MANCHESTER: 620, Deansgate, 3. Telephone: Blackfriars 4412. NEW YORK OFFICE U.S.A.: 111 Broadway, 6. Telephone: Digby 9-1197.



By foreseeing the needs of the public; by anticipating the practical requirements of setmakers; by helping to solve the problems of service engineers and dealers; by building reliability and performance into every product they make, **MULLARD** have created a unique business philosophy.... in a word **INTRINSICALITY**



WW-103 FOR FURTHER DETAILS.

# Wireless World

ELECTRONICS, TELEVISION, RADIO, AUDIO

## Hi-Fi Television

IN an endeavour to fill, even if only in part, the gap caused by the cancellation of the London Radio and Television Show planned for September, we have devoted a considerable amount of space in this issue to a survey of technical trends in both television and sound receivers and to a review of new sets. The overall picture of what's new in the domestic equipment field is further enhanced by the inclusion of reviews of the recent German Radio Show, the International Show held in Paris and, for full measure, an impression of the East German industry gained during a visit to the Leipzig Autumn Fair.

What is the state of the art in television receiver design? As will be seen in the following pages there are few new techniques, and in fact some manufacturers are resorting to sales gimmicks. One interesting development is the inclusion of a d.c. restoring circuit to maintain black level in receivers. Perhaps the most significant is the growing use of transistors and there are now completely transistorized receivers both in this country and abroad. In the radio field the coming of semiconductors saw the introduction of low-quality portables—the ubiquitous “transistor”—and it is to be hoped that the same trend will not invade the television field.

This leads us to ask whether the present-day television receiver is really doing justice to the transmitted picture. Only those who have seen the picture on a monitor in a control room of either the B.B.C. or I.T.A. have had the opportunity of judging the true quality of our 405-line service, and it would be true to say that few viewers are getting anything like the transmitted picture.

In his Fleming Memorial Lecture to the Television Society a few months ago Dr. R. D. A. Maurice, of the B.B.C. Research Department, discussed “The specification of an adequate television signal.” One might ask, adequate for what? He showed the lengths to which the broadcasting organizations go to ensure a good quality picture, and also the impairment introduced in receiving installations. It would be unfair to lay the responsibility for poor pictures solely at the door of set manufacturers. For, although they are by no means blameless, they do, by and large, go to great lengths to design receivers to give a satisfactory picture. We believe that the weakest link in the chain is the aerial installation. This is undoubtedly where the users of a relay service have the edge on their “over-the-air” neighbours. The operators of relay services have the advantage of either a cable feed from the station, or of an aerial installation at a vantage point often well outside the range of interference. It need hardly be added that a good aerial installation—not necessarily outdoor—is of even greater importance for reception on the u.h.f. bands.

Despite what we have said we believe there is a growing demand for a hi-fi television set. This does not necessarily mean large-screen, but it must have those refinements which have been pruned in the run-of-the-mill receivers, in order to keep them within certain price limits. Some discerning viewers will want one thing and some another—better scanning linearity, maximum bandwidth, greater tuning stability, video response adjustment—but one thing that is certain to be demanded is better sound reproduction. In the average set it is deplorable—in fact, little better than from a pocket transistor set. One reader has recently suggested we should publish the design of a tuner for Bands I and III, so that he can feed the television sound into his audio amplifier.

It would be interesting to know readers' views.

VOL 71 NO 10  
OCTOBER 1965

# DOMESTIC RECEIVER SURVEY

## TECHNICAL DESIGN TRENDS IN TELEVISION AND SOUND

**T**HE television receivers produced by the majority of groups this year are similar to last year's with the exception of several smaller points of detail. In many cases system switching (405-625) is ganged to the push-button tuners so that selection of any programme is simply a matter of pushing the appropriate button. In the Thorn range of receivers solenoids are used to drive the system switch to minimize mechanical linkages.

The "panorama" (Mullard) or "rimguard" (Mazda) type of tube presentation is to be seen in many receivers. This type of picture tube does not require any implosion screen, the face of the tube being directly accessible to the viewer. The tube is completely safe from implosion by virtue of a steel band that surrounds the rim of the tube. The advantage of this type of picture presentation is that there is no dust trap behind the old type of

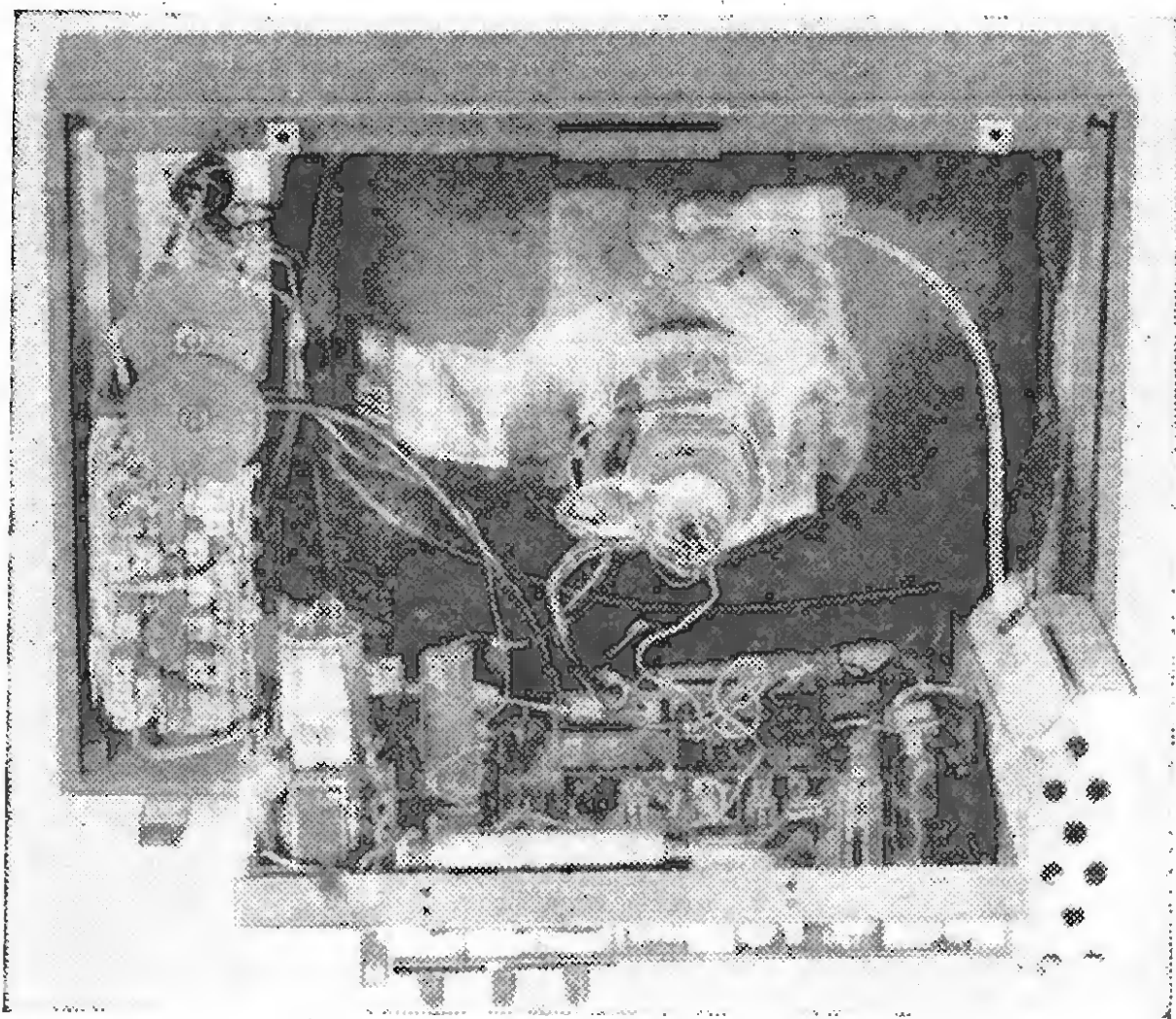

Rear view of the Pye 16 in transistor television receiver showing the i.f. strip and integrated tuner.

implosion screen and at the same time reflections caused by room lighting are minimized.

Although the majority of receivers are similar to last year's models there are one or two important trends emerging which will probably set the pattern for future receivers.

The first of these is the use of an "integrated" tuner, that is, a combined tuner for all the v.h.f. and u.h.f. channels. The first production receivers to feature the use of such tuners in this country are those marketed by the Pye/Ekco group. Also featured in the receivers produced by this group are fully transistorized vision and sound i.f. amplifiers.

The second is the use of a black-level stabilizing circuit to reinsert the d.c. component; this is incorporated in

the latest Bush/Murphy receivers. These receivers also feature transistor sound and vision i.f. amplifiers as do the latest in the Sobell/G.E.C./McMichael range. Transistor u.h.f. tuners are used in many otherwise valve receivers and in fact the days of the "all-valve" television receiver appear to be numbered.

Mean-level a.g.c. is used exclusively, the a.g.c. potential being derived in the conventional manner from the grid circuit of the synchronizing pulse separating valve. In the Plessey and Grundig receivers, however, an amplified mean-level system is used. In hybrid receivers, in which transistors are employed in the sound and vision i.f. amplifiers, a transistor is also used to provide the necessary forward bias for the i.f. and r.f. transistors but again mean-level circuits are used. In the Bush/Murphy and Sobell/G.E.C./McMichael receivers the a.g.c. potential is taken from a low impedance point in the video amplifier but in the Pye/Ekco receivers a separate video detector diode is used.

The normal complement of transistors is two for a u.h.f. tuner, one operating as an r.f. amplifier, the other as a self-oscillating mixer. In the v.h.f. tuner three transistors are normally employed, the first operating as an r.f. amplifier, the second as a mixer and the third as the local oscillator. A self-oscillating mixer cannot be used on v.h.f. because of the close spacing of channel 1 (45 Mc/s) to the i.f. (38 Mc/s). In the case of separate tuners a gain differential exists in that the gain of a typical u.h.f. transistor tuner is some 20 dB and for a v.h.f. tuner it is about 30 dB. This problem can be simplified in an integrated tuner.

Since a self-oscillating mixer cannot be employed on v.h.f. it follows that the v.h.f. part of an integrated tuner will require three transistors. However, the first stage can be common provided the transistor is suitable for v.h.f. and u.h.f. amplification and also that the combination of the u.h.f. and v.h.f. tuned circuits can be satisfactorily accommodated. If the mixer transistor is arranged to be of the self-oscillating type on u.h.f. the v.h.f. mixer transistor can be employed as an i.f. amplifier to equalize the gain. The block diagram of the Pye tuner is shown in Fig. 1.

Separate band filters apply the r.f. signal to the base of the r.f. amplifier transistor (AF186). The output of the r.f. transistor feeds the u.h.f. and v.h.f. bandpass filter circuits. A unique feature of the Pye tuner is in the use of a folded halfwave lecher line that is tuned at each end by a variable capacitor. The halfwave tuning elements are "U" shaped, allowing each end to be connected to the split stators of the tuning capacitors. On u.h.f. the circuits are halfwave but tuned at each end and hence the midpoint of the line is a low potential point. The v.h.f. tuned circuits are connected to this point of the line without influencing the u.h.f. performance. Since no switches are involved for this particular function no trouble from switch re-setting accuracy is experienced. On v.h.f. the u.h.f. bandpass tuning elements act as low inductance conductors for the v.h.f. circuits, thus placing the split stator tuner capacitors in shunt with the v.h.f. bandpass coils. In

Underside of the transistor v.h.f. unit used in the Bush/Murphy hybrid receivers.

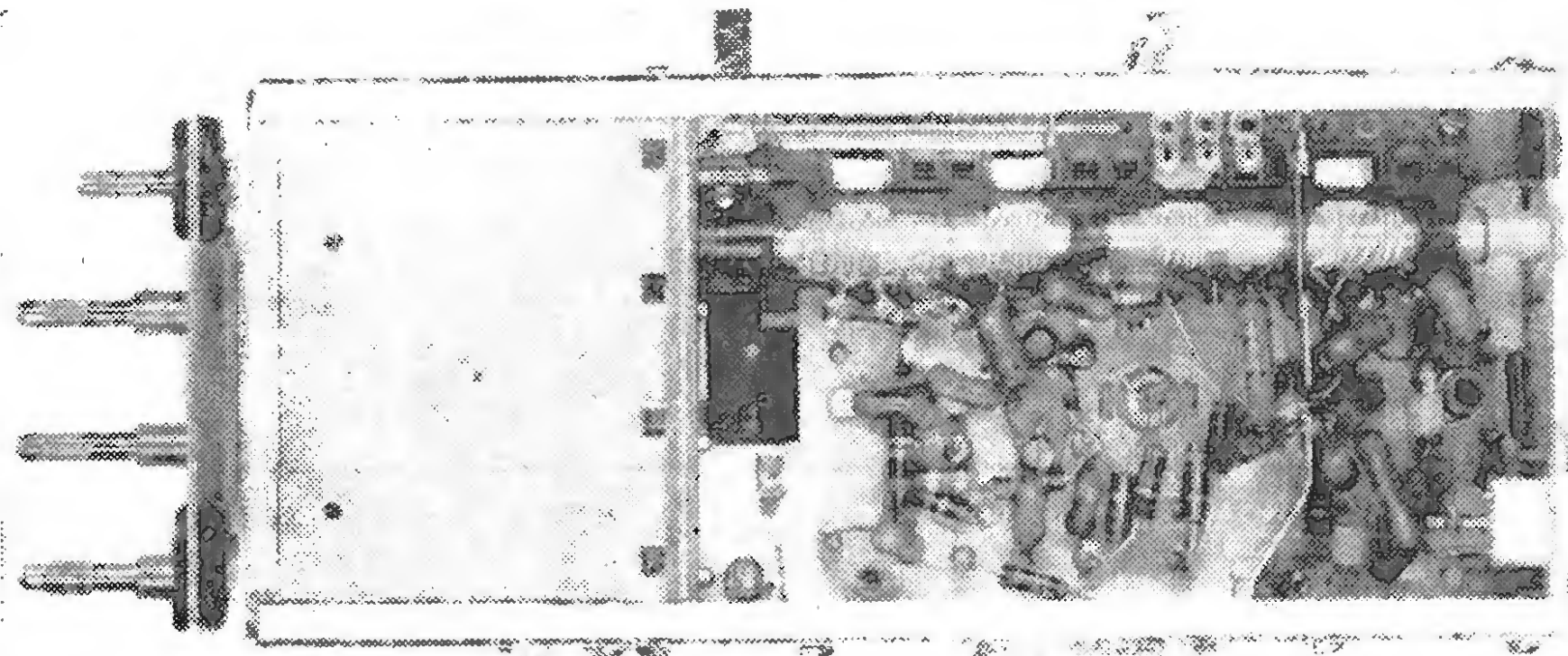

this way the same tuning capacitors are able to tune both the v.h.f. and u.h.f. circuits to any channel in Bands I, III, IV and V.

The u.h.f. and v.h.f. oscillator stages are not common. On u.h.f. a second AF186 transistor functions as a self-oscillating mixer, while on v.h.f. two AF178 transistors are used, one as the oscillator and the other as the mixer. The latter has two functions, for u.h.f. the particular circuit is re-arranged so that it becomes an additional i.f. amplifier. The overall tuner gain is substantially constant throughout the v.h.f. and u.h.f. bands.

The integrated tuner produced by Sydney S. Bird (Cyldon Type IT100) and used by several set makers features a push-button system switch ganged to the tuner. Only 60° gang rotation is used to eliminate errors due to gear drive. This tuner also employs four transistors (2 off AF186 and 2 off AF178) and has a substantially constant gain (27 dB) over the whole band.

Receivers manufactured by the Pye Group and the newest designs from the Bush/Murphy and Sobell/G.E.C. groups incorporate transistor i.f. amplifiers. In these receivers three transistors are used in the vision i.f. with a further two in the sound i.f. In the Bush range of receivers an additional transistor is used as an a.g.c. amplifier, the a.g.c. input being derived either from the anode or the cathode of the video amplifier valve depending upon which system of modulation is being used. In the case of the Pye receiver a second

video detector diode is employed to generate the necessary a.g.c. voltage together with the intercarrier sound signal and two transistors are employed as amplifiers between this diode and the i.f. transistors. The Sobell receivers also use a double-diode video detector circuit to reduce system switching but a single a.g.c. transistor driven from the cathode of the video amplifier is used.

With the use of transistors in the tuners and i.f. amplifiers the heater chain of the receiver requires a rather large mains dropping resistor. In these hybrid receivers the resistor is in fact replaced by a diode to reduce the power in the heater chain.

An additional problem of the hybrid receiver is that of obtaining the required power supply for the transistors.

In the Pye and Sobell receivers the d.c. for the transistors is obtained from the heater chain itself, see Fig. 2. A capacitor is shunted across the transistor supplies so that the a.c. component of the heater current flows to earth and the d.c. component of the heater chain is used to drive the transistor circuits. In parallel with the input to the transistor circuits in the Pye receiver is a positive temperature coefficient resistor (p.t.c.). The function of this resistor is to eliminate the switch-on surge that would possibly damage the transistors when the receiver is first switched on. When the resistor is cold it has a low value and therefore effectively shorts the transistors out. As it warms up its resistance increases and thus

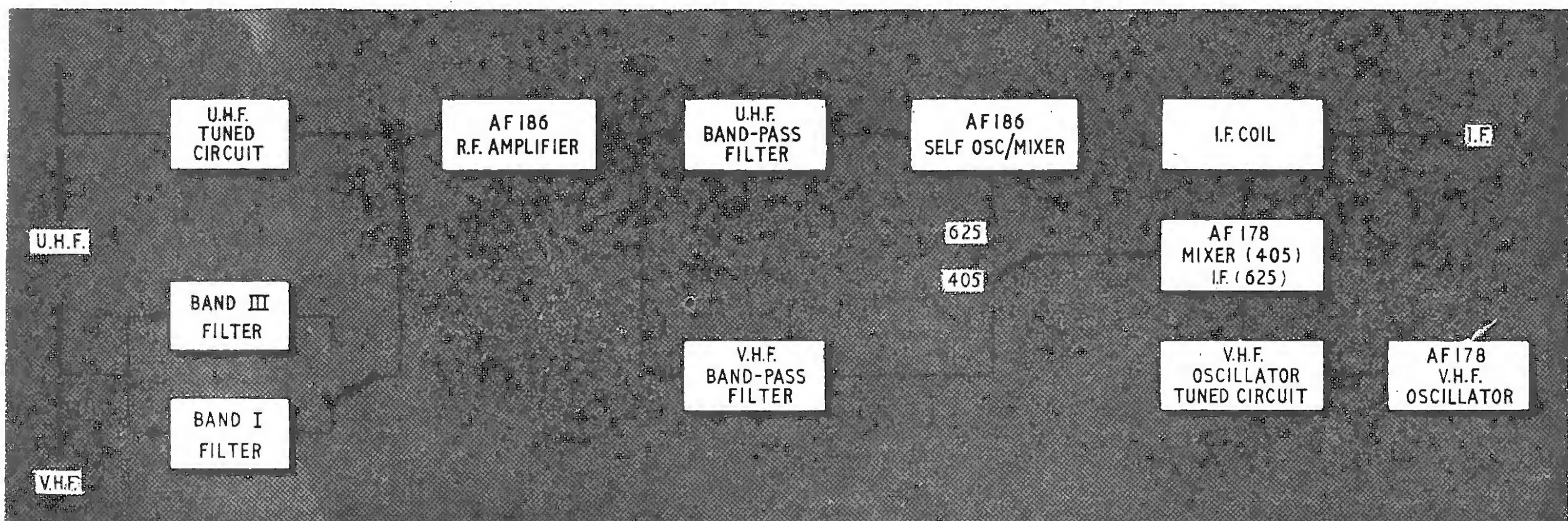

Fig. 1. Block diagram of the Pye integrated tuner.

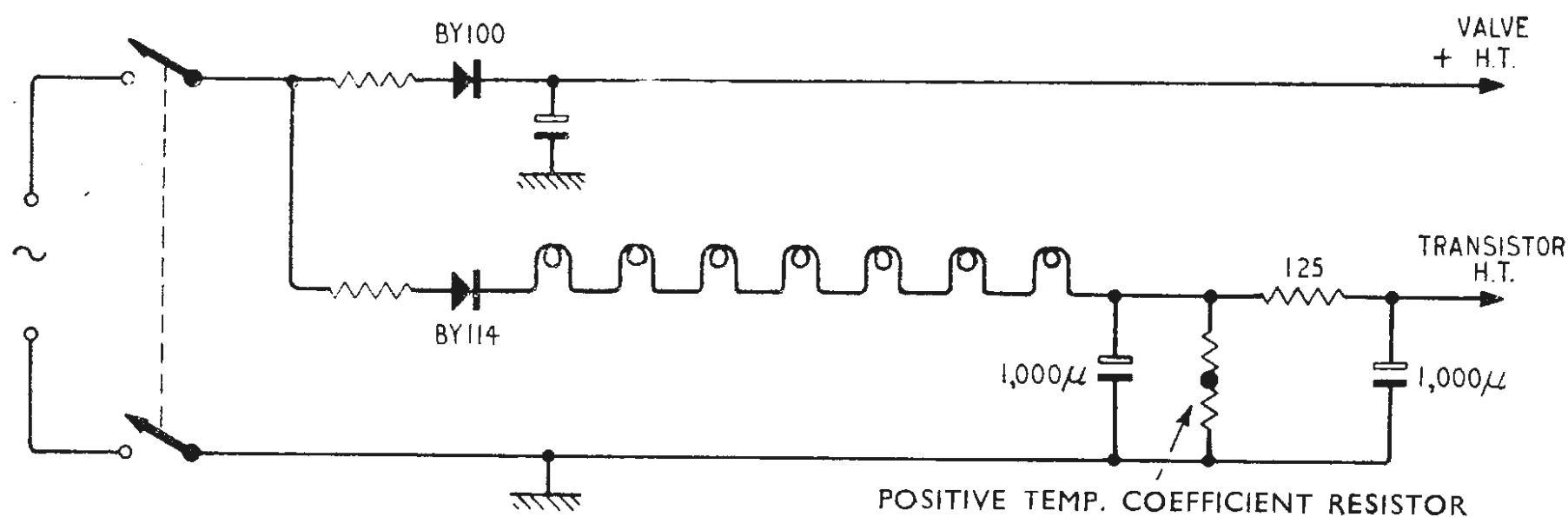

Fig. 2. Power supply system employed in the Pye hybrid receiver.

permits a voltage to be applied to the transistors. In this way it serves the same purpose in the reverse way to the normal thermistor used in the heater chain. In the Sobell receivers a catching diode is connected between the transistor h.t. line and the cathode of the vertical output valve to eliminate the switch-on surge.

The transistor supply in the Bush receiver is also unusual in that the d.c. for the transistors is obtained from the vertical timebase. The transistor circuits are connected in series with the timebase output valve as part of the cathode resistor. To prevent voltage variations a shunt regulator transistor is used (see Fig. 3). The regulator transistor acts as an emitter follower and holds the transistor h.t. potential at substantially the base potential of the transistor.

The Thorn range of receivers now includes a 16-in portable. The receiver chassis is basically the same as the 950 series (19 and 23 in) which employs selenium e.h.t. rectifiers (see *W.W.*, January, 1965), a mains auto transformer in the power supply and a 3-gang transistor u.h.f. tuner. In the 16-in receiver, however, the limited space precludes the use of a mains auto transformer and it has been replaced by a capacitor in series with seven of the valves, the remaining four being wired in series with the receiver's h.t. supply circuit.

The video amplifier and synchronizing pulse separator circuits in most receivers follow conventional lines; the Bush/Murphy circuit, however, is slightly unusual in that it incorporates a black-level stabilizing circuit. This circuit has been previously described (*Wireless World*,

May 1964) and is shown in Fig. 4 together with the contrast control and c.r.t. blanking circuits.

The principle of the circuit is that the pentode valve is normally non-conducting but driven into conduction on the trailing edge of the synchronizing pulse. When the valve conducts it charges the cathode capacitor to a voltage dependent on the black-level of the signal applied to the screen grid. The cathode voltage therefore effec-

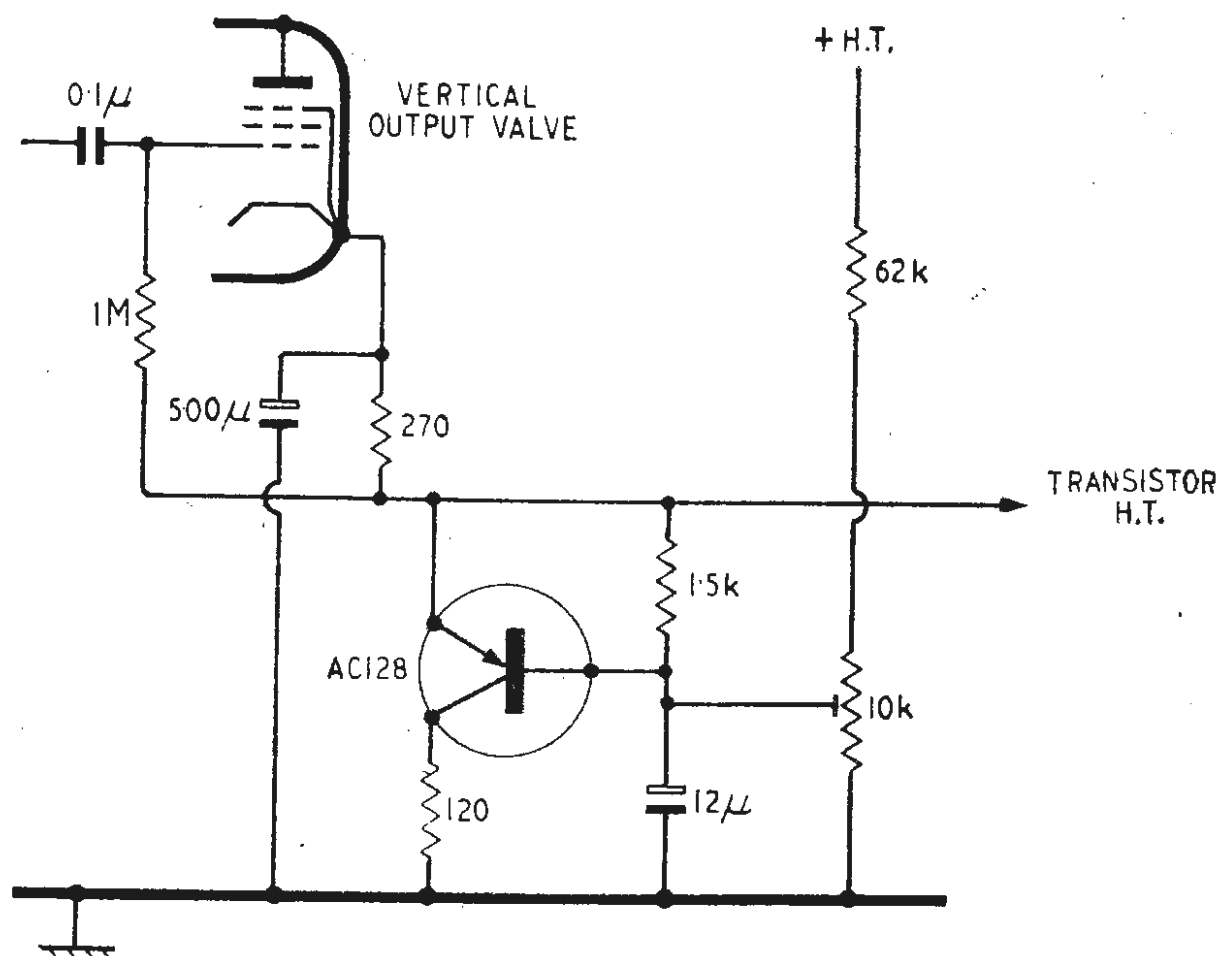

Above:—Fig. 3. Bush/Murphy transistor h.t. regulator circuit,

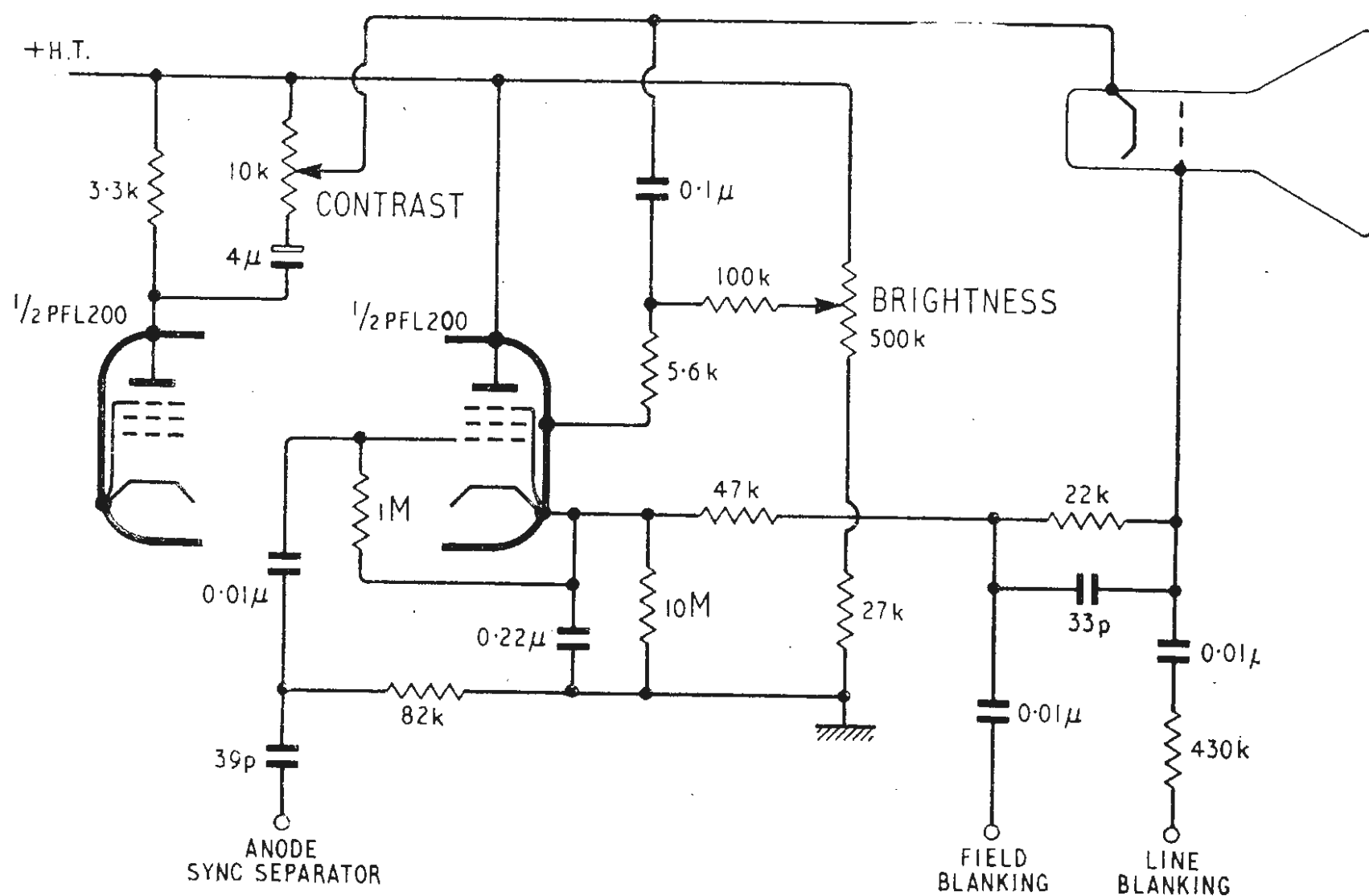

Left:—Fig. 4. Contrast control, blanking and black-level stabilizing circuit of the Bush/Murphy receivers.

tively follows the black-level variation of the picture tube cathode and this d.c. potential is applied to the picture tube grid. In this way the grid and cathode of the picture tube move up and down together so that variations in black-level caused by the mean-level a.g.c. system are not reproduced by the picture tube. Brightness control is affected by variation of the screen-grid potential of the valve.

Flywheel synchronizing now appears to be incorporated in virtually all receivers. Line oscillators consist of sine-wave oscillators controlled by a high impedance phase detector or in some cases a multivibrator or a blocking oscillator with a cathode follower.

Diode phase detectors are employed almost exclusively but in the Decca receiver a triode-pentode phase detector is employed which is of the coincidence type and in the Philips range of receivers a triode phase detector is used.

A feature of the Philips receivers is the increase in the e.h.t. potential to 18 kV which together with the use of the "panorama" tube presentation gives an increased brightness which is claimed to be some 20%. These receivers also feature a transistor u.h.f. tuner.

Also featured on one range of Philips receivers is an automatic time switch coupled to an electric clock. The "on" and "off" time can be pre-set so that the receiver switches itself on automatically for a selected programme. A clock/timer switch is also incorporated in the R.G.D. "Night Owl" combined television and u.h.f. sound receiver.

### Sound receivers

Radio receivers this year have followed more or less established lines, with one or two minor exceptions. The modern technique of modular construction, which by now has been applied to most branches of electronics, including television, is gradually infiltrating into radio. The Alba Scout (model 737) and the Ekco PT447 are typical examples. Ekco have eliminated the usually untidy situation surrounding the mixer/oscillator circuitry with their

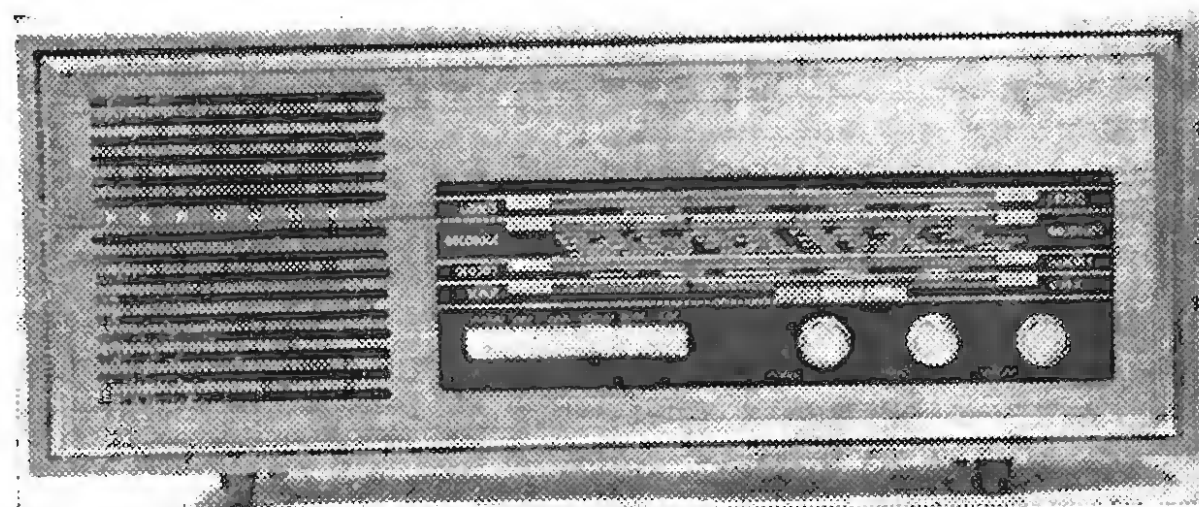

Ferranti A1143 mains-operated transistor receiver.

"integrated switch pack" (I.S.P.) which is featured in the PT447 and A449 and will be included in future models. The pack houses the waveband switches and associated mixer/oscillator wiring. The push-button wavechange switches are totally enclosed—a technique which is being increasingly used in the domestic field.

Transistor receivers in sizeable wooden cabinets are noticeably on the increase (teak in particular) and these are often quite broad and quite unrelated to the size of the chassis. Because of the use of larger loudspeakers, reproduction from these receivers is markedly better than from the ubiquitous "transistor" (*sic*).

The relative scarcity of mains-operated transistor receivers has always been something of a mystery (to us) since portability is not necessarily of primary importance. This year's additions to this class include the Ferranti A1143 (which incidentally uses a German standard D.I.N. tape recorder socket) and the Ekco A449. Both have wooden cabinets and the A449 includes the "integrated switch pack."

The crowded situation which exists at the high-frequency end of the medium-wave band is eased to some extent with the bandspread scales which appear on a number of receivers—and Radio Caroline has found its place on the scale in some cases! Alba, in the Japanese-

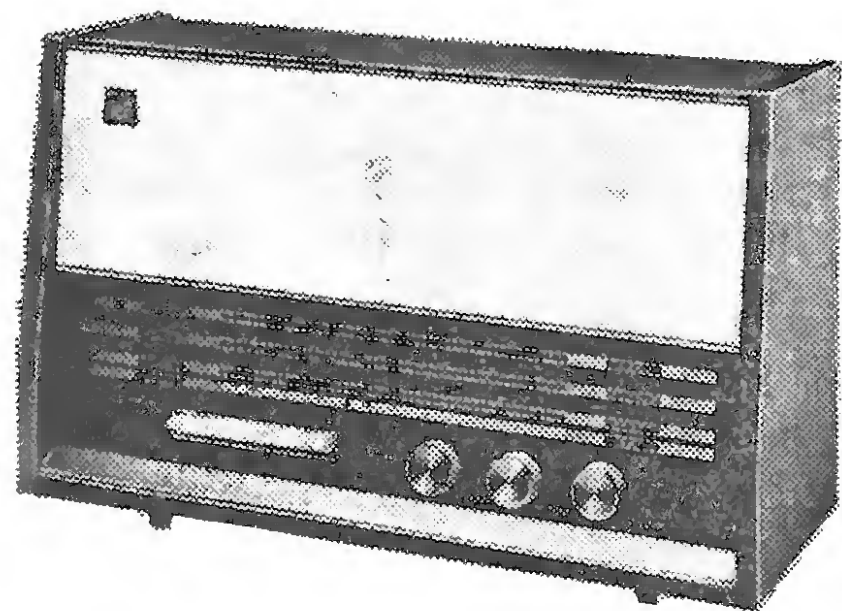

Ekco mains-operated transistor receiver (A449) with integrated switch pack.

Fig. 5. Basic circuit of stable oscillator for s.w. reception in Grundig "Ocean Boy" and "Satellit" receivers.

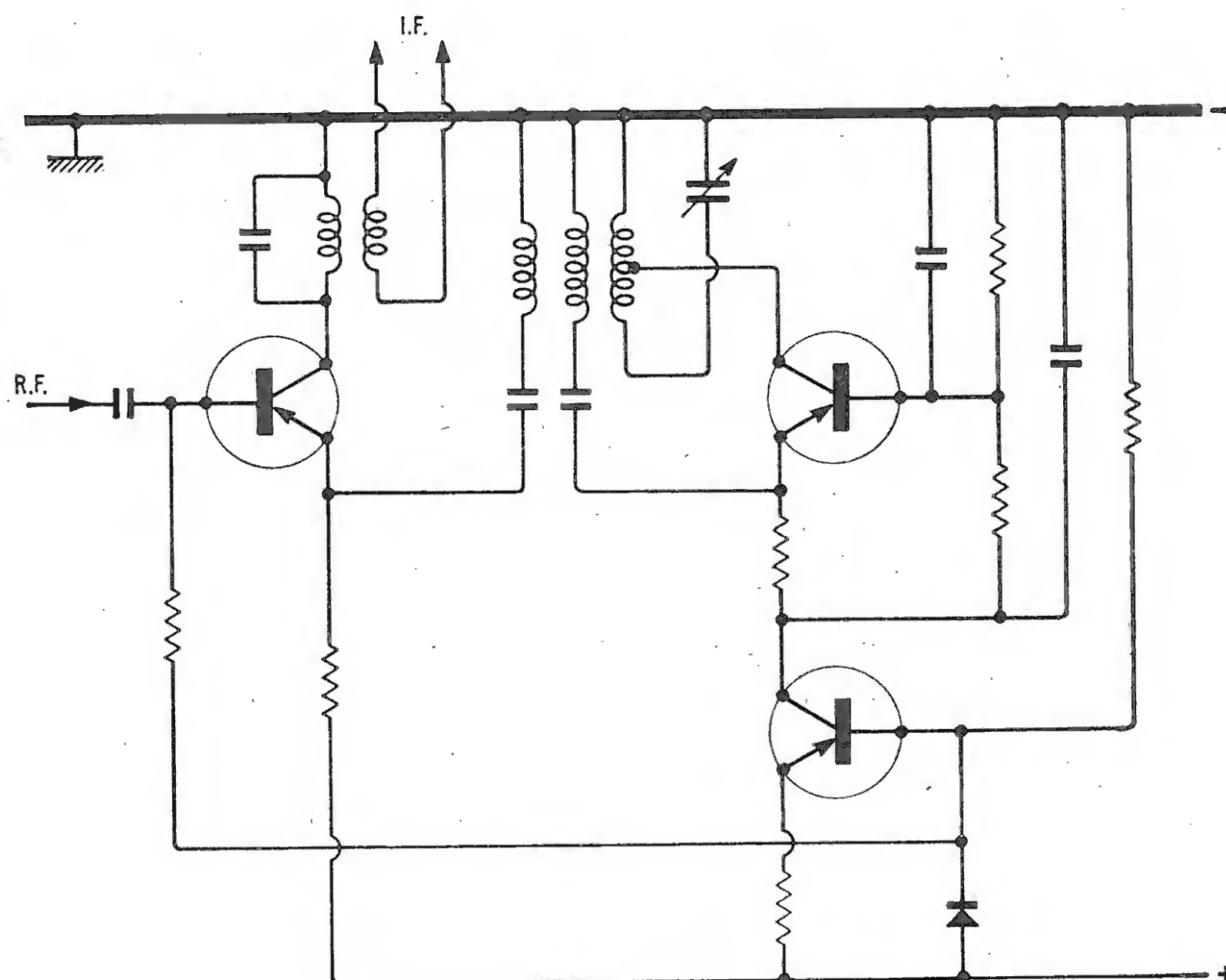

manufactured Transcontinental (model 838) choose the alternative and provide a fine tuning control, which is operative on all wavebands.

One of the minor problems of the portable transistor receiver is the provision of an illuminated scale and/or pilot lamp to indicate that the set is switched on. Filament lamps are quite greedy and will often consume as much power as the receiver itself. One solution for the pilot lamp is to use a transistor oscillator and step-up transformer in an inverter stage to provide sufficient voltage to fire a small neon tube. A number of receivers now use a dial illuminated by a filament lamp and operated by a spring-loaded push-switch often incorporated in the tuning control.

Whilst on the subject of dials, the confusing appearance of the average medium-wave scale could perhaps be eased by removing the station names completely (as is done in the U.S.A.) and instead a printed list of stations could be supplied on the inside of the receiver back or battery-cover. (We note that such a list is included in a brochure of one manufacturer.)

There have been no drastic changes in sound receiver circuitry—the vast majority using well-tried designs. Complementary transistors dominate the output stages, but there are still a large number of receivers using transformer-coupled output stages—the advantage of transformerless stages not being so great in receivers with small loudspeakers. In the more ambitious radiograms, complementary driver stages and p-n-p output transistors are common. Silicon transistors both in audio and r.f. stages are now appearing more frequently.

The Grundig Ocean-Boy receiver, now available in this country, uses a separate oscillator transistor. The mixer emitter current is stabilized by an additional transistor, for reception on the short-wave band. The essential circuitry is shown in Fig. 5. The new Grundig Satellit uses a similar circuit and also the mixer stabilizing arrangement, but includes an r.f. stage, an additional i.f. stage, and for the six s.w. bandspread ranges, separate oscillator, mixer and stabilizing stages. Both sets incorporate a 9 kc/s whistle filter, a feature not frequently met. The receiver uses a total of 18 transistors.

## THE SEASON'S SETS

MANY of the British receiver manufacturers have held exhibitions during what has traditionally become known as "Show time." From the information gained from visits to these shows and from the manufacturers who were not holding exhibitions, we have compiled a brief summary of the new television and sound receivers and radiogramophones. In the following pages these are listed under trade names and where several come from the same "stable" these are grouped together under a combined heading.

It will be obvious that in the available space it is impossible to do justice to all the new sets on the market, but we hope this section of the issue will provide an "arm-chair" radio show for readers.

At the end, under "Imported Sets," we have listed most of the makes which were shown at one or other of the trade exhibitions. Some of the latest products from overseas will be found elsewhere in the issue in the reviews of the German Radio Show and the International Show held in Paris.

### K.B., Regentone, R.G.D.

"Night Owl" is the name given by R.G.D. to a combined television set, v.h.f. sound receiver and clock/timer, in which the clock can be used to switch on either the television or the sound receiver at a predetermined time, thereby providing an early morning alarm or ensuring that a selected programme is not missed. A two-hour delay

timer allows the receiver in operation to be switched off automatically at the end of a programme. The set is based on S.T.C.'s "Featherlight" chassis but has a larger cathode-ray tube—a 12-inch.

K.B.'s latest television set is a 23-inch de luxe model, KV107. It has two front-facing loudspeakers, an illuminated u.h.f. tuning scale and push button v.h.f. station selection, with two sliding doors on the cabinet. Flywheel sync and pre-set fine tuning are used, and the u.h.f. tuner can be either a valve or a transistor unit. K.B. has also introduced a four-waveband radiogram with stereo output, the KG031. It has a seven-valve chassis, a B.S.R. record changer and each sound channel has an output of 2.5 watts, driving a 10in×6in elliptical speaker. Stereo balance and tone controls are provided.

A portable 12-transistor radio receiver from Regentone, the TR419, covers the medium- and long-wave bands and v.h.f. It has front-facing controls, a 3½-inch speaker and a 25-inch telescopic aerial for v.h.f. The K.B. model KR019 is similar in electrical design.

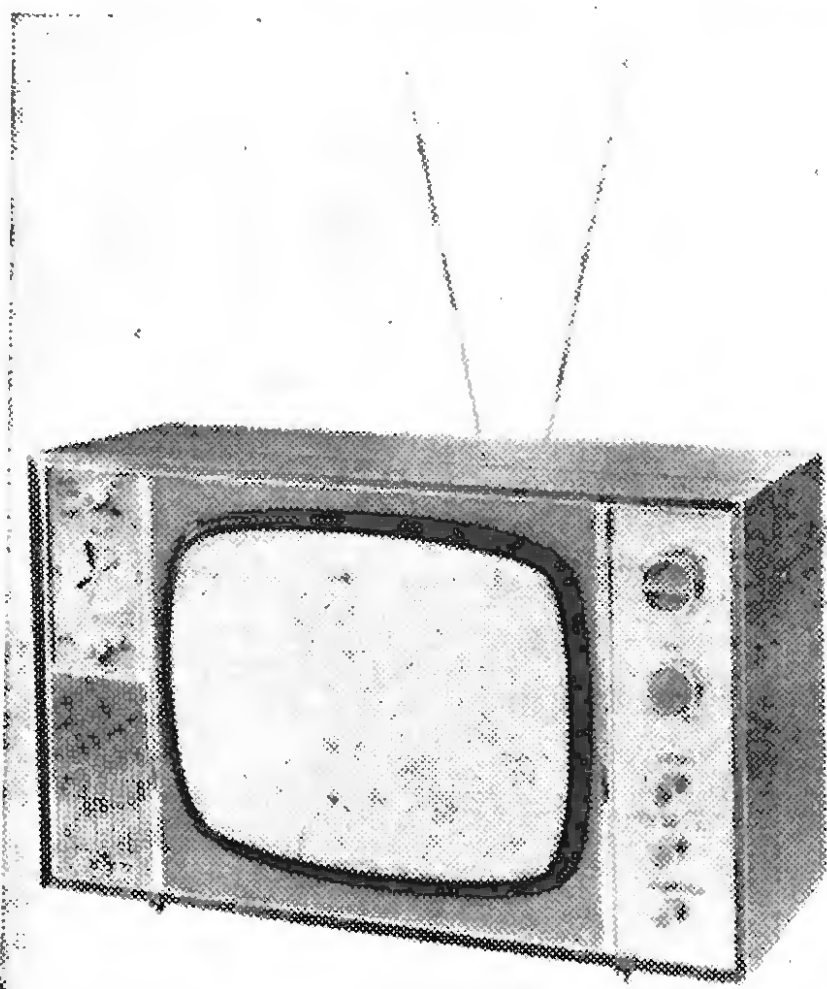

(Left) R.G.D. Night Owl combined receiver and timer.

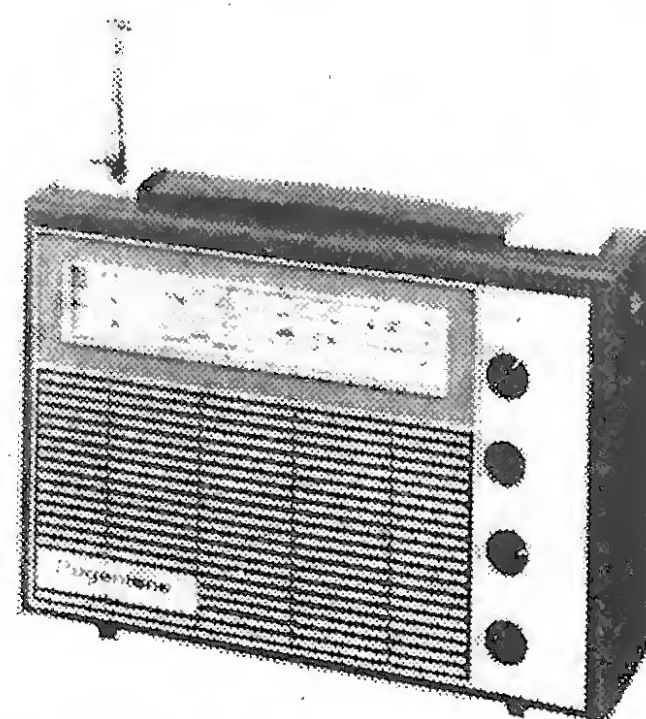

Regentone TR419 transistor receiver.



# Ferguson, H.M.V., Marconiphone, Ultra

A 16-in portable television set in "brief-case" format weighing 27 lb has been introduced by this group (British Radio Corp.). Known variously as the "Courier" (Ferguson), "Companion" (Ultra) and "Sixteen" (H.M.V.), it features automatic line system switching (using switches operated by solenoids when the channel selector is turned to the BBC-2 position); a transistor u.h.f. tuner; pre-set ("memory") fine tuning for individual channels; and a capacitive mains dropper which

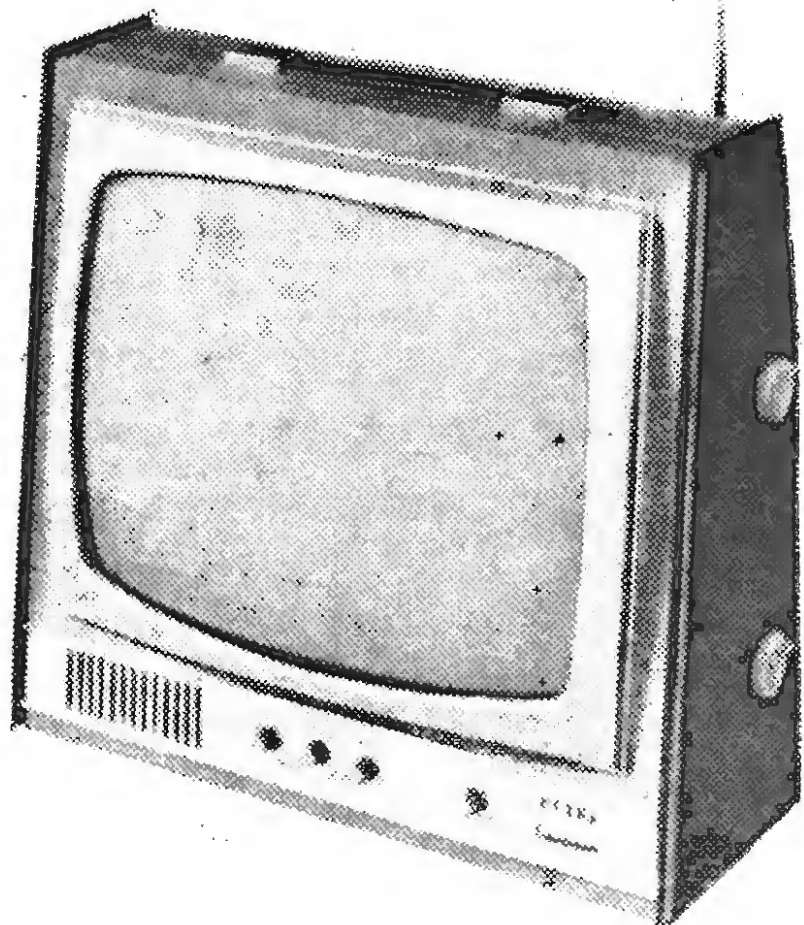

*Ultra Companion portable receiver.*

reduces heat dissipation within the cabinet but restricts the set to a.c. mains supplies. The chassis is the standard Thorn design on a single printed-circuit board, except that in the interests of compactness the scanning and sound output circuits have been separated off and conventionally wired.

All four makes have an all-transistor radiogram with four wavebands and stereo output; a common chassis and record-changer (Garrard 3000 with low-mass pickup arm and high-compliance ceramic cartridge) are used, but the cabinets and other details of presentation vary (as

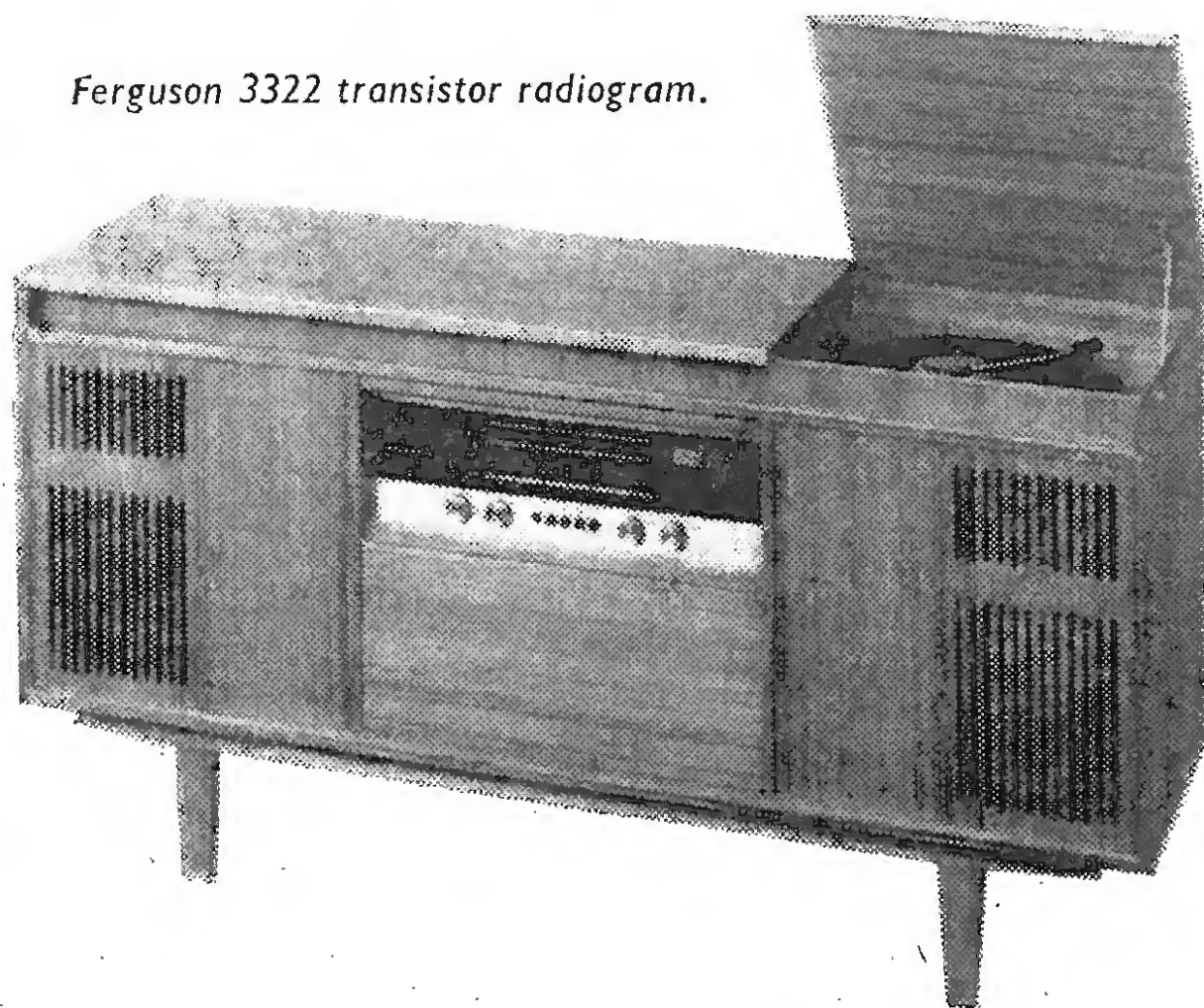

*Ferguson 3322 transistor radiogram.*

do the prices). The Ferguson 3322 has 7 watts output per channel while the H.M.V. 2318, Marconiphone 4310 and Ultra 6320 have 3 watts output per channel. Marconiphone, who, unlike the other makers, supply only through wholesalers, have a remarkably low priced four-waveband radiogram (monophonic), the 4308 "Popular," at 39½gn.

Dual-purpose car/home portable transistor radio receivers are also featured by the group—the Ferguson Auto Twin Mk. II, the H.M.V. "Convertible," the Marconiphone "Travelmaster" and the Ultra "Road Ranger." All are characterized by a "car" push-button which when operated cuts out the internal ferrite aerial and substitutes a permeability tuned circuit for working with the car aerial, thereby improving performance and reducing ignition interference. Wavebands are m.w. and l.w. but H.M.V. have a de luxe model providing in addition v.h.f., and another model housed, unusually, in a wooden (teak finished) case.

## Decca

Latest of this company's radiograms with stereo output is the SRG700 Mark II, which has an all-transistor circuit, four-waveband reception and a Garrard AT6 record changer with a Decca Deram pickup. In each sound channel the 5-watt output drives a system of four loudspeakers: a 10in×6in bass unit, and three 4-in units for middle and high frequencies which can be rotated on their axes to vary the sound direction by an edge-operated wheel on the front of the cabinet.

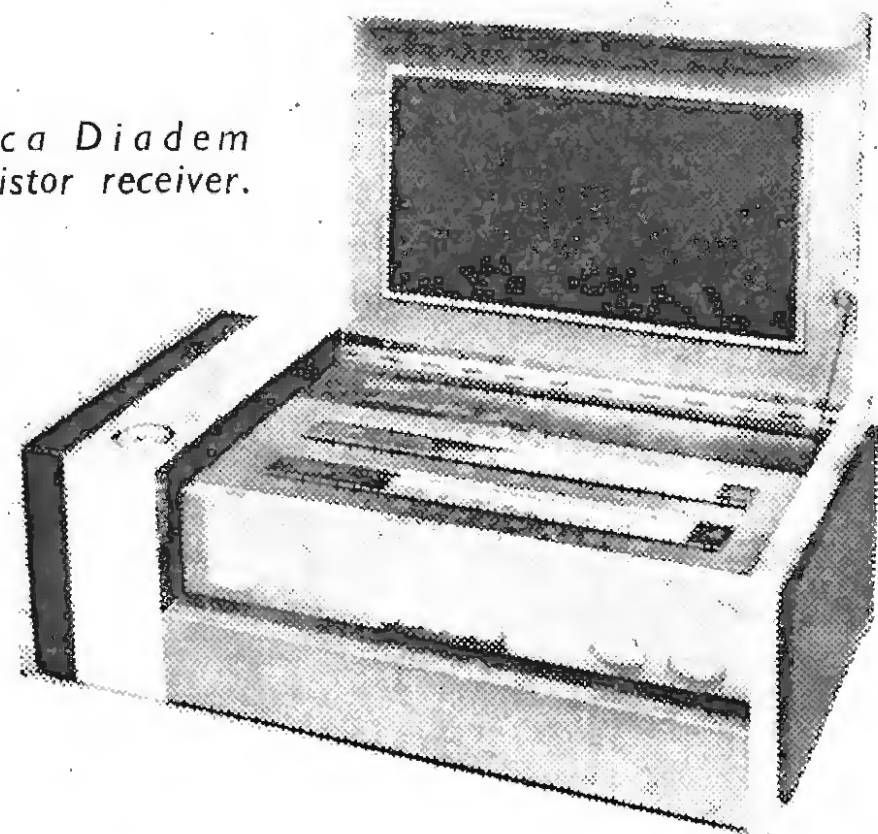

*Decca Diadem transistor receiver.*

All the new portable transistor radio receivers cover v.h.f. as well as m.w. and l.w., and one model, the TP89, priced 30 gn, includes also a short-wave band (16.4-51 m). A telescopic aerial is provided for v.h.f. and s.w. reception. One of the three-waveband sets, called the "Diadem," is presented in a solid wooden cabinet (teak or rosewood), with a lid covering the horizontal tuning scale, after the fashion of a musical box.

Two 19-inch and one 23-inch dual-standard television sets all have forward-facing loudspeakers and a pre-set fine tuner for 405-line channels.

# Pye, Ekco, Ferranti, Invicta, Pam, Dynatron

New television receivers from the group use a transistor integrated tuner with six push button settings which can be preset mechanically to select any six channels in Bands I, III, IV and V. A separate line system switch is not required, changing from 625 to 405 lines is automatic when selecting the channels. Some of the television receivers which use the integrated tuner are—the 19-in Pye 40/F (69½ gn), the 16-in Invicta 7166 (65 gn) and the 23-in Pam 5151 (82 gn).

In their radio receivers, Ekco have introduced the recently developed integrated switch pack which they state will form the heart of new Ekco press button receivers for several years. The pack contains the wave change circuit in one precision-built unit which is connected to the printed circuit by only four wires. One of the first Ekco receivers to incorporate the switch pack is the PT447 (25 gn) which uses a 7-in elliptical speaker giving over 1 W output. Four wavebands are covered, and v.h.f. Sockets for earphone, tape recorder and external aerial are provided.

Features of the range of Dynatron radiograms with stereo output include separate tuners and preamplifiers and amplifiers utilizing semi-conductor circuit tech-

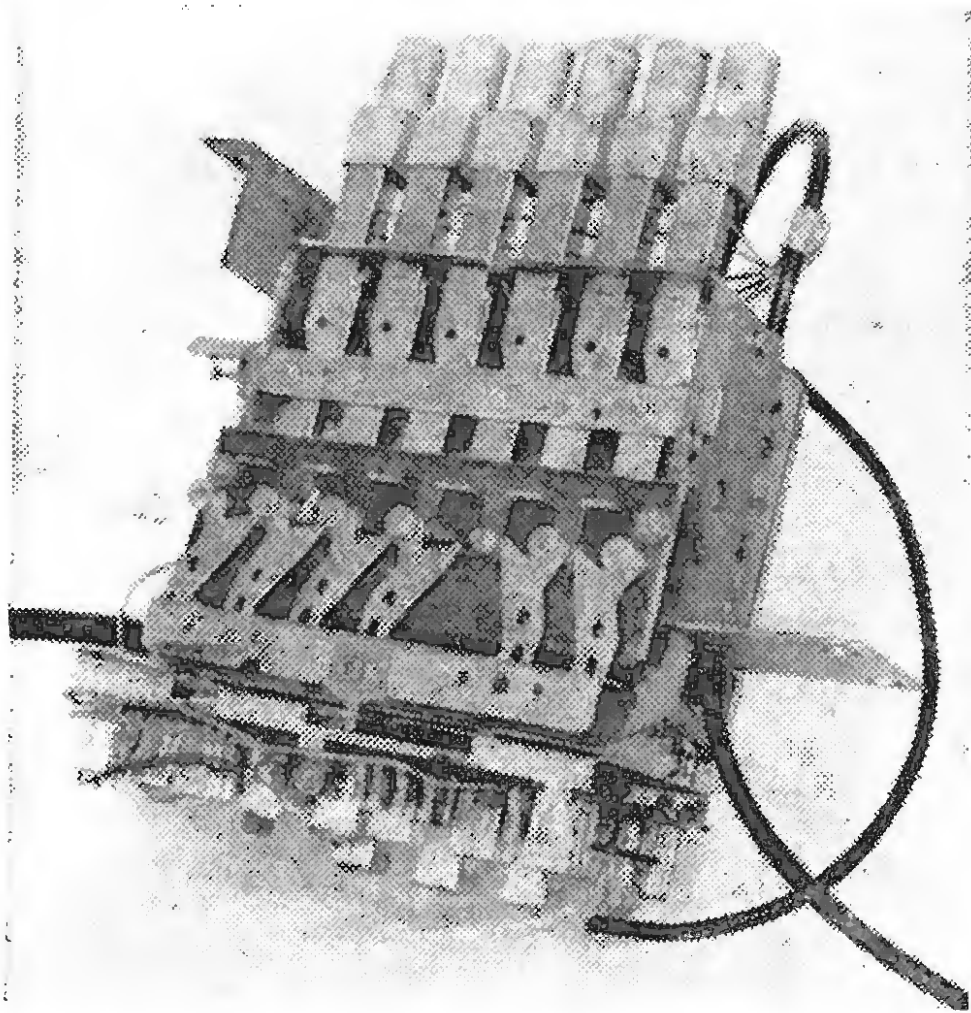

"Integrated" all-transistor tuner used in some of the Pye/Ekco group's television receivers.

niques. The range is divided into two groups—the 16/20 Transpower and the 12/10 Transpower. Details of models in the 16/20 group include a four-waveband press button radio tuner (long, medium, short and v.h.f.) which is adaptable for multiplex stereo radio by plugging in a decoder unit; a preamplifier; and two 10 W push-pull output amplifiers which at full power have less than 3% distortion and an overall frequency response of 30 c/s to 15 kc/s  $\pm$  3 dB; a Garrard AT6 Mk. 11 auto changer. In this group, prices range from 132 gn for the RG37S to 260 gn for the RG29S. Models in the 12/10 group cover the same wavebands but the power output is 5 W per channel and the overall frequency response is 80 c/s to 14 kc/s. Prices range from 99 gn for the RG41S to 139 gn for the RG39S.

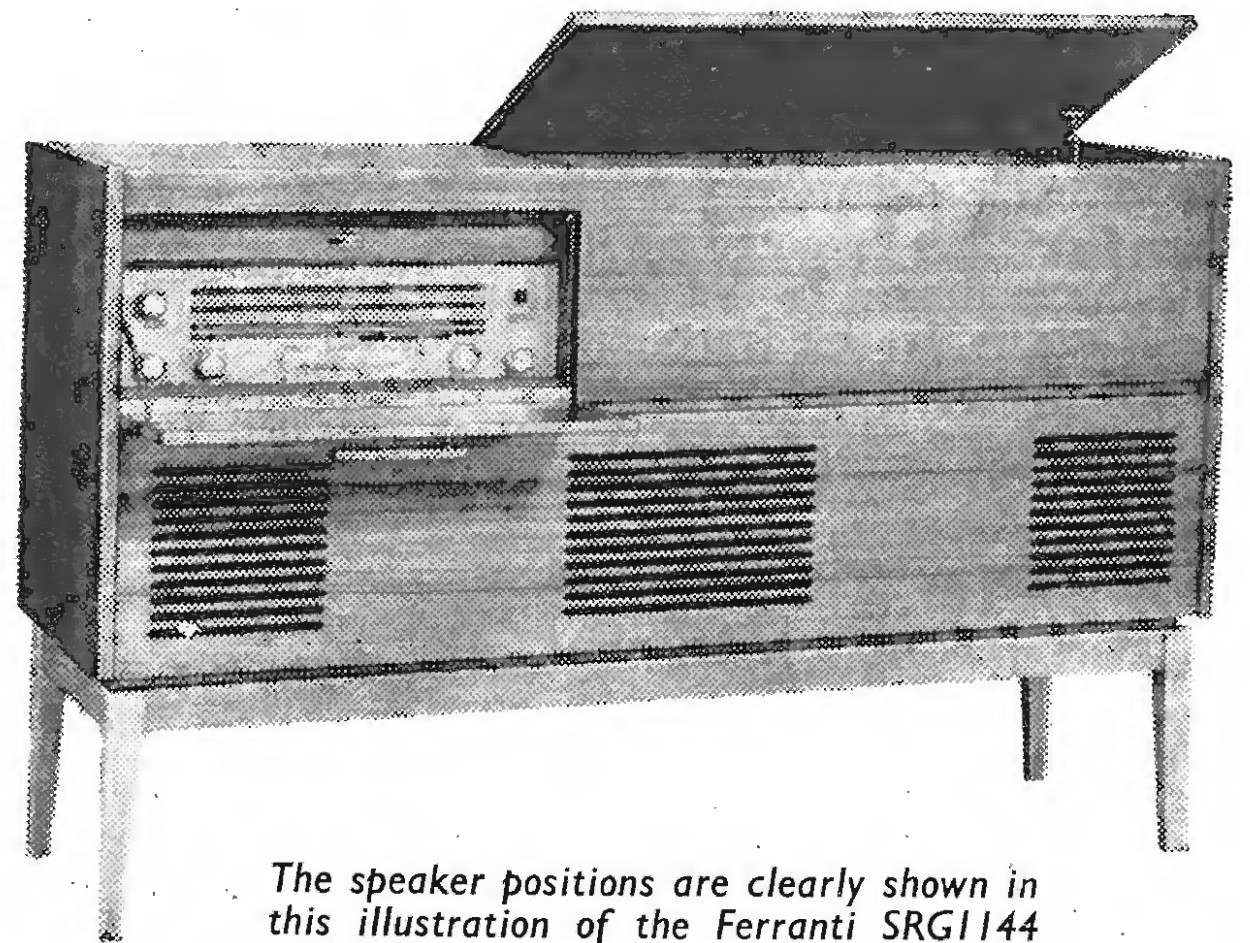

The speaker positions are clearly shown in this illustration of the Ferranti SRG1144 three channel radiogram.

Ferranti have introduced a three-channel four-waveband radiogram, SRG1144 (96 gn) in which the output from the pickup is fed into a 500 c/s crossover filter for frequency separation in order to minimize intermodulation distortion. Signals above 500 c/s are fed to left and right channel amplifiers for normal stereo reproduction, but signals below 500 c/s, not being particularly directive, are fed to a third amplifier channel which drives a 10 in elliptical bass-reflex speaker mounted between the two 8-in left and right speakers. Music power is 3 W for each stereo channel, 5 W for the bass channel and distortion is less than 0.5%. Sensitivity is 5  $\mu$ V for 500 mW output.

Two table model transistor receivers for a.c. mains operation are available from Ferranti. These are the four waveband A1143 (33gn) and the A1149 (15 gn) covering the l.w. and m.w. bands.

## Roberts

Latest addition to the Roberts range of portable radio receivers is the R404. This two-waveband set employs seven transistors (including a complementary pair in the output stage feeding one watt to a 7×4in loudspeaker) and three diodes. Sockets are provided for a car aerial and earphones. The wooden case, which stands on a ball-bearing turntable, measures 11½×7×4in. It weighs 6 lb and costs 17 gn.

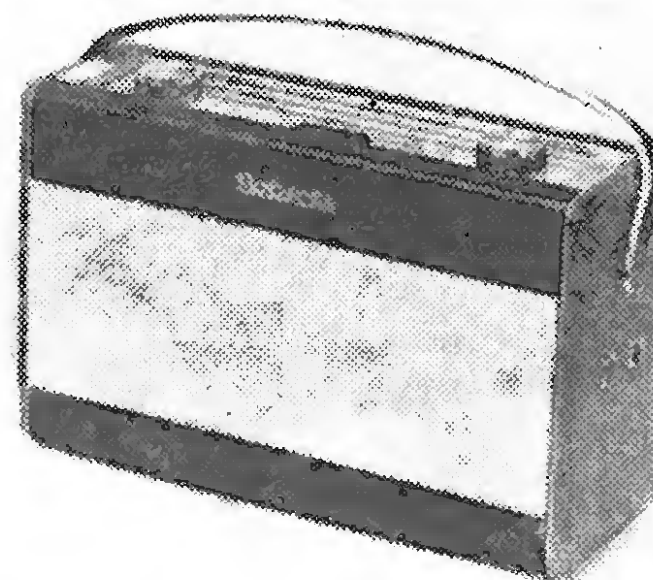

The Roberts R404 which is mounted on a turntable.

## Bush, Murphy

Included among the new transistor radio receivers from Bush are the TR116 (17 gn) with long-, medium- and short-wave coverage and the TR130 (15 gn) for the medium- and long-wave bands. Two receivers which incorporate bandspread tuning for the lower end of the m.w. band are the TR132 (17 gn) covering also the l.w. band, and the VTR133 (23 gn) with l.w., m.w. and v.h.f. coverage. A new radiogram with stereo reproduction, the SRG107 (125 gn) has been introduced. Three wavebands are covered, long, medium and v.h.f. The circuit contains twelve semiconductors, and an output of 5 W per channel energizes a loudspeaker system which incorporates six speakers in an acoustically balanced network. Three new television receivers, each available with a u.h.f. tuner, have also been announced. These are a 19-in TV 135R (59 gn), a 19-in TV 135 (65 gn) and a 23-in TV 138R (71 gn). The tuner costs an additional 8 gn for each model.

In the Murphy Magna range three new transistor radio receivers are available each of which has an output of approximately 1 W. Bandspread at the lower end of the m.w. band is featured on two of the models. The B815 (16 gn) for medium and long waves, and the B837 (23 gn) which also covers the v.h.f. band. A tele-

scopic aerial is fitted for v.h.f. reception and provision is made to connect an external v.h.f. aerial. The other model, the B818 (15 gn) has push button selection for long and medium bands and 208 m. Sockets for car aerial, earphone, tape recorder or extra speaker are fitted.



The Murphy Magna will operate for approximately 250 hours from two 9V batteries of the Ever Ready PP9 type.

Three new 19-in television receivers—V939 (63 gn), V979 (66½ gn) and V929 (59 gn)—are announced together with a 23-in model (69½ gn). Each model can be obtained with a u.h.f. press button tuner for BBC-2 at an additional cost of 8 gn.

## Sobell, G.E.C., McMichael, Masteradio

Three screen sizes are available in the new range of television receivers and six of the seven models use identical chassis. The 19 in receivers are models 1012 (Sobell), 2012 (G.E.C.), 3011 (McMichael) and 4011 (Masteradio) and the 23 in are models 3013 (McMichael) and 4013 (Masteradio). (The price of the 19 in models is 69 gn and the 23 in models 79 gn.)

The model 2015 (G.E.C.) is the first British 13 in receiver to appear on the market and uses an RCA tube. The chassis is a modified version of the 1010 (which

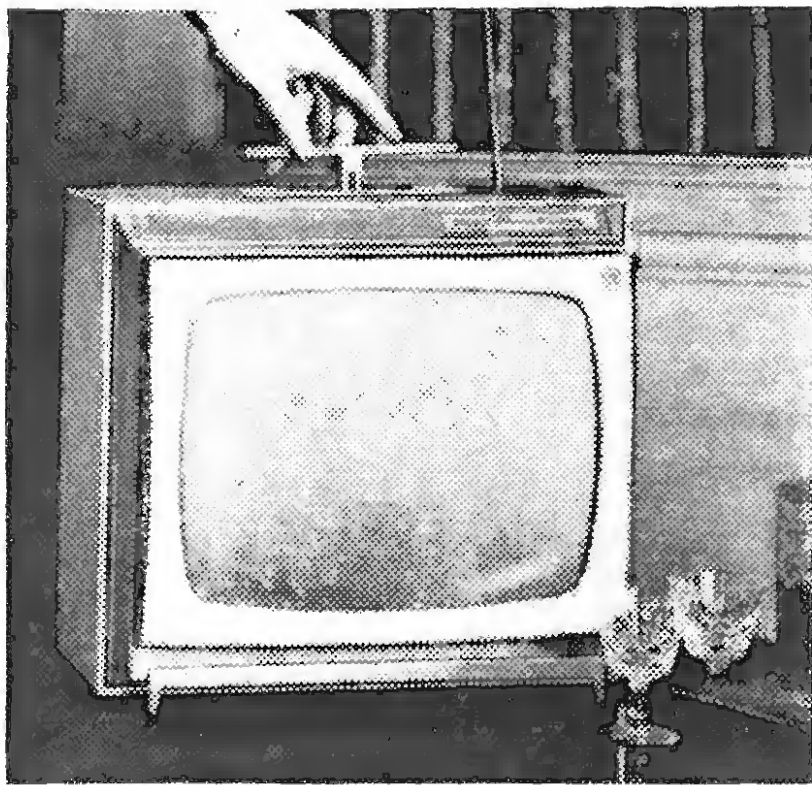

G.E.C.'s portable receiver (2015) which employs a 13 in tube.

uses the Mullard v.h.f. tuner and a transistor u.h.f. tuner)—a PL81A is used in the timebase circuits in place of the PL500.

The 19 and 23 in receivers are hybrid, 10 transistors being used in the v.h.f. and u.h.f. tuners and i.f. stages, with valve timebases. An OC44 is used as an a.g.c. amplifier which controls the first i.f. stage and provides delayed a.g.c. to the u.h.f. and v.h.f. first stages. The supply lines for the transistor stages, incidentally, are taken across resistors in the d.c. heater chain.

There are two basic types of sound receiver, one receiving a.m. and f.m. broadcasts, the other a.m. only. The G.817 (G.E.C.) and D.517 (Masteradio) have 10 transistors, which include an AF178 low-noise v.h.f. amplifier and an OC81-AC127 complementary output stage. Three bands are covered, m.w. (with bandspread in the region of 1.41-1.8 Mc/s), l.w. and v.h.f. The loudspeaker measures 6×4 in and the price of both models is 22 gn. The a.m.-only receivers are the G.826, G.828 (G.E.C.) and M126 (McMichael), which cover the m.w. and s.w. from 5.7-10.2 Mc/s. Bandspread is available on both s.w. and m.w. A 25 Ω-impedance socket is provided for tape recording, etc. The dust-proof loudspeaker is 4½ in dia. and the three receivers cost 14½ gn each.

Again, two basic types are available in radiograms, the D.580 (Masteradio), S.680 (Sobell) and G.982 (G.E.C.) at 85 gn and the G.980 (G.E.C.) and G.981 (G.E.C.) at 110 gn. The latter use the Garrard 3000 turntable fitted with a stereo ceramic cartridge and diamond stylus, while the former are equipped with either a B.S.R. UA30 or the Balfour Princess turntables. The tuner section is provided with a tuning meter, bandspread on m.w. and a.f.c. on the v.h.f. band. The s.w. coverage is from 5.7-16.5 Mc/s. Sockets are provided for tape recording and tape playback. The complementary output stages (AD161-AD162) provide about 7 W per channel into 10×6 in and 3 in loudspeakers.

# Philips, Cossor, Stella

Features of the new range of Philips television receivers are increased e.h.t. giving, it is said, a 12.5% increase in brightness, and the inclusion of an electric clock which automatically switches the set on at a pre-set time. The two receivers incorporating a clock are the 19 in model 9173 (72 gn) and the 23 in model 3173 (81 gn) which

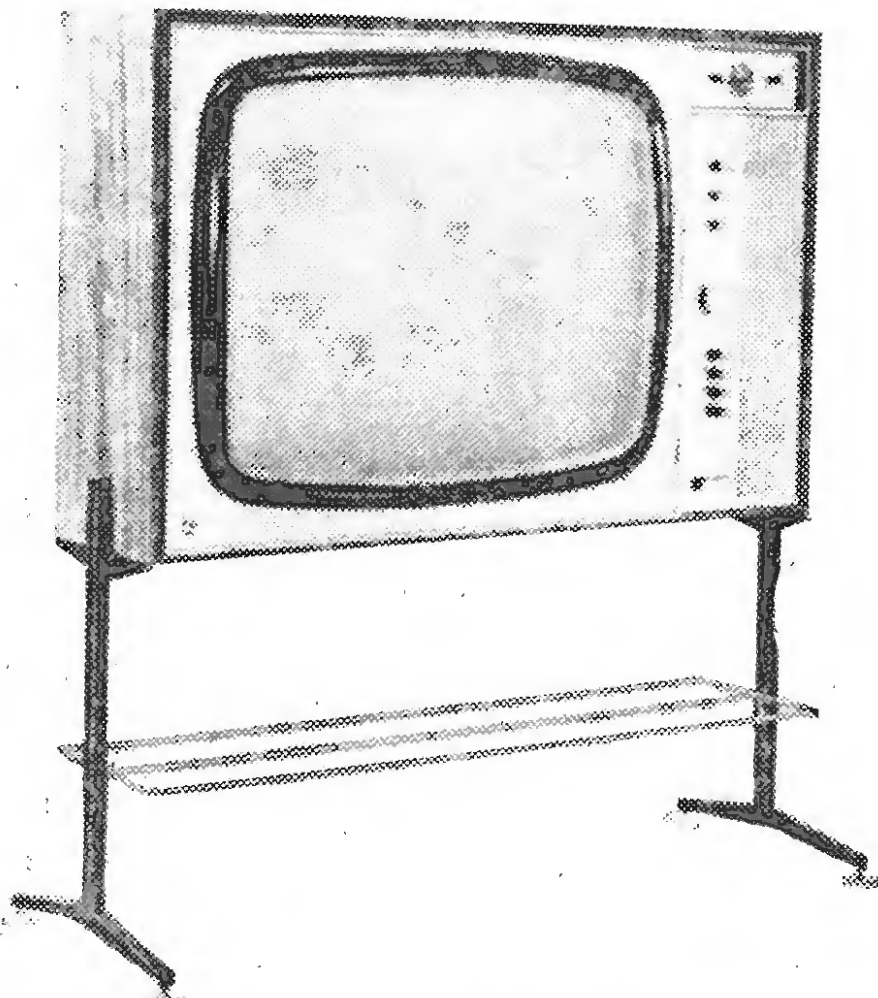

One of the two Philips receivers which incorporate a clock timer.

each employ a panorama tube, as do the companion models 9170 (63 gn) and 3170 (75 gn) which have different styled cabinets and no clock. A new 19 in receiver (CT1974A/02) has been introduced by Cossor which has the same basic chassis as the Philips range.

Two new transistor portable radio receivers are added to the Philips range—the 345T “Le Mans” and 247T “Cadiz”. A feature of the “Le Mans” (15½ gn) is that its normal output of 400 mW can be stepped up to 1 watt for group listening. Two i.f. stages give increased selectivity. A 6×4 in speaker is employed and sockets are provided for car aerial, tape recorder and earphone.

A feature of the new Stella ST7228T a.m./f.m. portable is a special biasing circuit which reduces distortion normally introduced as the battery voltage falls. Nine transistors and seven diodes are employed. The ST7228T weighs 4 lb and costs 25½ gn. Cossor’s latest portable is the CR1315T (13½ gn) which covers the l.w.

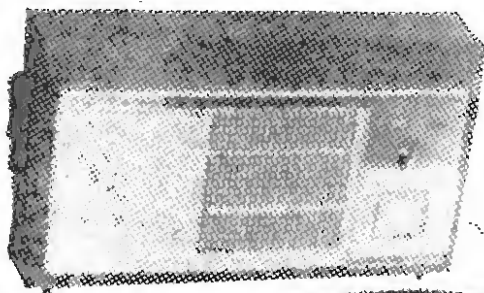

The smallest radiogram? It weighs 5½ lb, covers l.w. and m.w. bands, and is powered by six U2 batteries. (Philips)

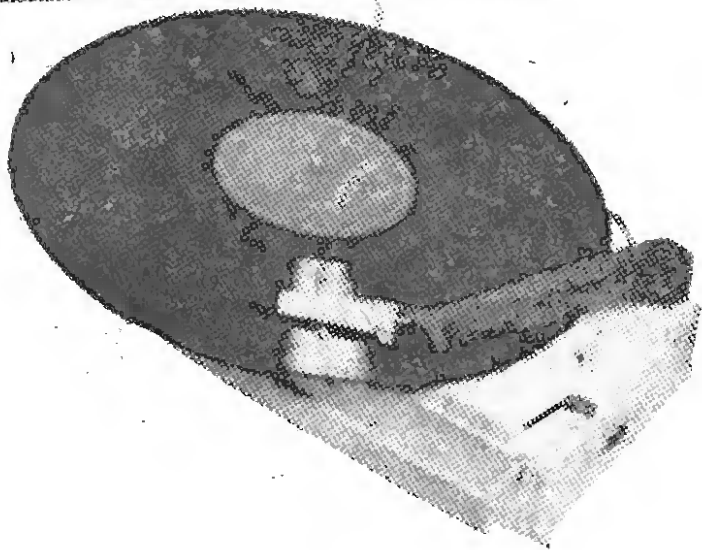

and m.w. bands, has a 500 mW output from its 5×3 in speaker and has provision for a car aerial and earphone.

Four radiograms, two with stereo outputs, comprise the new Studio Range of Philips. They are the Studio Three (39½ gn) the radio of which covers the m.w. band only, the Studio Five (47 gn) covering both l.w. and m.w. and employing a Garrard 1000 autochange unit; the Studio Seven (61 gn) with an output of 3 W on each channel; and the Studio Nine (72 gn) covering v.h.f., l.w. and m.w. with stereo output and the Garrard 2000 autochanger.

## Defiant

Under the trade name of Defiant, the Co-operative Wholesale Society has introduced several new models among which are four new dual-standard television receivers, two radiograms and two radio receivers. The television receivers are the 19-in, 9A72U (72gn); the 19-in, 9B63U (79gn); the 23-in, 3A66U (81gn) and the 23-in, 3C65P (89gn): each uses the well tested Mk. 9 chassis with refinements. The 3C65U has separate push-button tuners for u.h.f. and v.h.f.; the u.h.f. tuner utilizes mesa transistors, whereas low-noise frame grid valves are used in the v.h.f. tuner. One of the radiograms, the PG1 (33gn) for a.m. reception and mono record reproduction has a four-valve circuit with a B.S.R. UA25 record changer. The other radiogram, the AF88, is “all transistor” (14 in all), has stereophonic output of 4 W per channel and is priced at 72gn. A Garrard 1000 series record changer, fitted with a Sonotone 20T1 stereo cartridge, is used. Both the new radio receivers—the A44 (14gn) and the A58 (16gn)—cover the l.w. and m.w. bands and employ 7-transistor circuits with a complementary-symmetry output stage. Power output is 0.4 W and 1 W respectively for the A44 and A58.

## Portadyne

Two new a.m. radiogramophones, one (RG400S) with stereo output, have been brought out by Dynaport Radio and Television. Both receivers cover three wavebands. The mono radiogram (RG880 costing 32 gn) has a 4.5 watt output from the three-valve receiver. The RG400S (38½ gn) has an output of 2.5 watts per channel. Both have four-speed automatic record changers and are fitted with roll away doors concealing the motor compartment.

## Fidelity

Latest introduction to this firm’s range of sound receivers is the RG32 radiogram with stereo output. The receiver covers m.w., l.w. and v.h.f. and each 3-watt sound channel feeds a 9in×6in loudspeaker. The record changer is a B.S.R. 10½-inch model. A companion monophonic radiogram is the RG31, again with a three-waveband a.m./f.m. receiver circuit.

Transistor portable radio receivers include the “Galaxy” which covers the long, medium and short (5.5-15 Mc/s) wavebands and has a telescopic s.w. aerial, and the “208” which provides bandspreading at the lower end of the m.w. band and has a 7in×4in loudspeaker.

## Grundig

The chassis for the two television receivers introduced some months ago by Grundig Great Britain are produced by Plessey but are housed in imported cabinets. The two models are the K230 (129gn) and the K450 (365 gn) which is also a radiogram with a stereo output of 6 W per channel. Both sets have 23 in tubes.

Three receivers have recently been introduced from Germany. The Transonette 60 (15½ gn) is a m.w./l.w. portable in a similar styling to the Transonette 70, which covers m.w. and s.w. The transistor line-up is different and the (complementary) output stage delivers about 1 W into a 5 in loudspeaker with a ceramic magnet.

The Ocean Boy receiver is now available in Britain, and was first introduced in Germany in 1962. The receiver features two loudspeakers, a tuning/battery meter, a.f.c. and covers l.w., m.w., s.w. (now 1.6-30 Mc/s, in four bands) and v.h.f. Bass and treble controls are included. For short-wave reception, the oscillator emitter current is fixed by an additional transistor in a stabilizing stage. The circuit has undergone considerable change, but the stabilizing stage and a 9 kc/s (a.m. only) whistle filter remain. The number of transistors in the audio

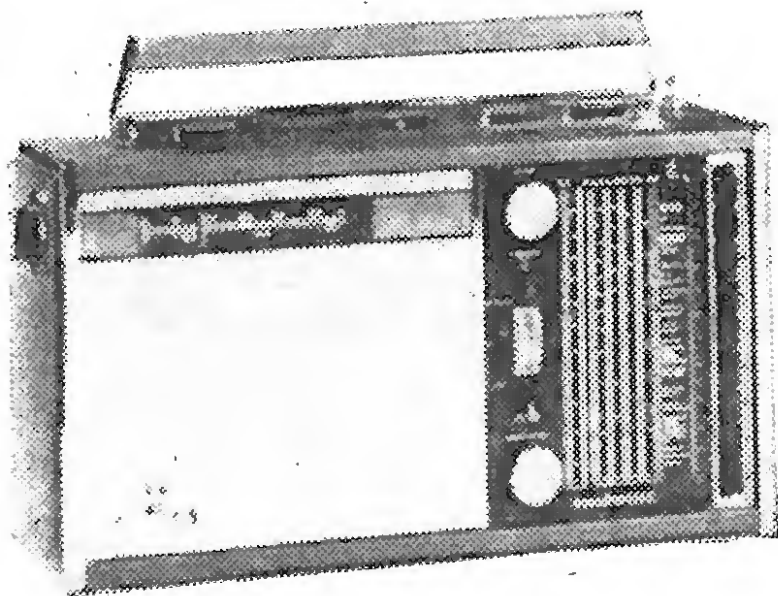

Grundig "Satellit" receiver with bandspread scale above the loudspeaker grille.

stages has been reduced from 8 to 4 and an additional i.f. stage is included. Ferrite beads are used in the emitter decoupling capacitor leads in one of the i.f. stages.

The Satellit (illustrated) is similar in appearance to the Ocean Boy, but with a bandspread scale added above the loudspeaker grille. The s.w. coverage is as for the Ocean Boy but the separate bandspread scales cover the 16, 19, 25, 31, 41 and 49 m bands. (An amateur version is available in Germany which covers the 10, 15, 20, 40, 80 and 160 m amateur bands). Three additional transistors are used in the bandspread circuits. (The price of the Ocean Boy and Satellit is 87 gn and 117 gn respectively.)

## Baird

The four latest television receivers in the Baird range all employ the same basic dual-standard chassis which has changed little since last year, although modifications, including the introduction of an integrated tuner, are being made. The 625 (76 gn) employs a 23 in panorama tube needing no safety screen. The second 23in receiver, a consolette with doors (654, costing 87 gn), and the 19in model 650 (68gn) are not fitted with panorama tubes. There is also a 27 in receiver for group

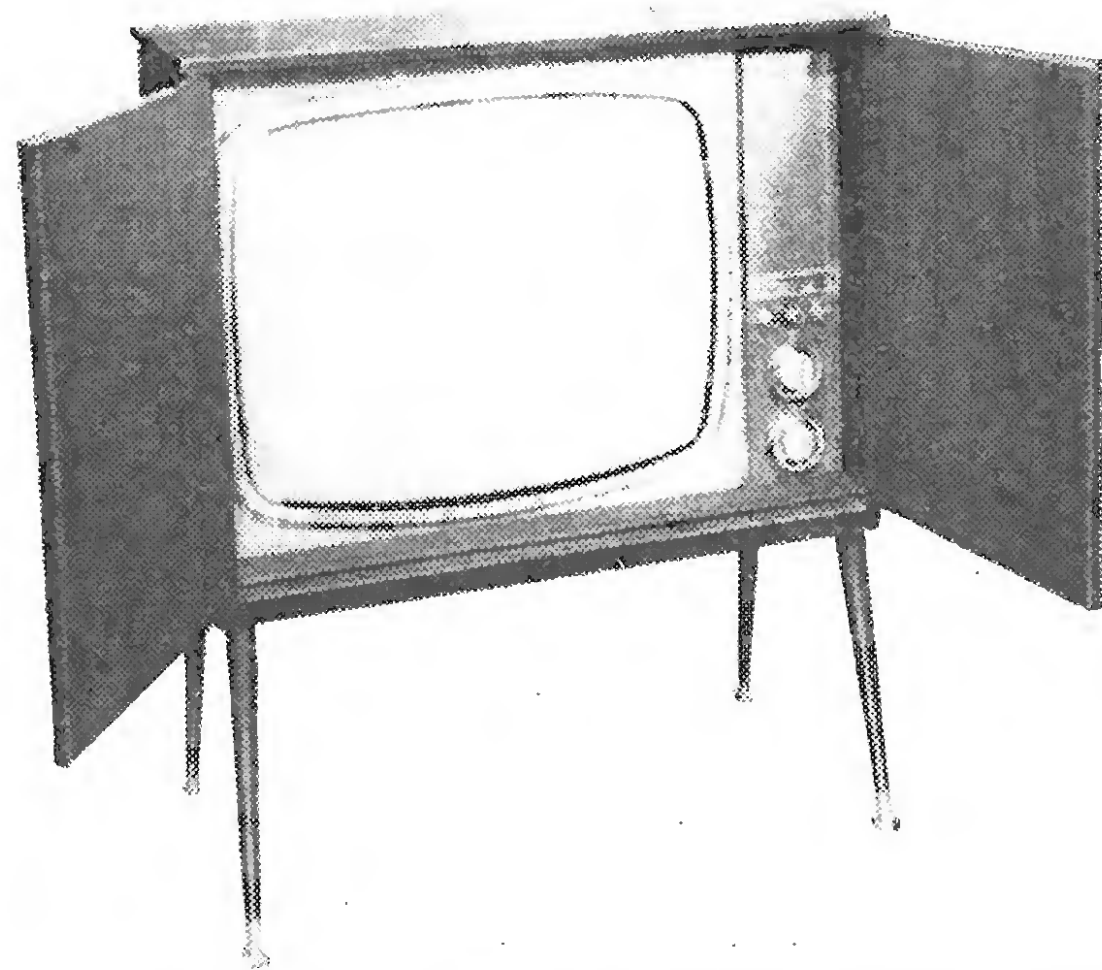

Consolette receiver (Baird 654) which employs a panorama tube.

viewing. This meets the "schools" requirements and is housed in a heavy wooden cabinet with protecting doors which when opened, together with a top flap, screen the tube from ambient light. This receiver (656) costs £125 and is exempt from purchase tax. Each of these receivers has a front facing loudspeaker and the 656 has an output of 5 watts.

Bandspread tuning at the lower end of the m.w. band is provided in the a.m. two-waveband transistor receiver 103 (13 gn).

## Hacker

Two specially developed Goodmans bass speakers, plus six high-note units, are employed in the Constellation RG50 radiogramophone introduced by Hacker Radio. Four of the treble speakers are mounted on extending panels that slide out from the sides of the cabinet to improve the stereo separation, the other two are fitted centrally. The twin class-A amplifiers each have an output of 10.5 watts and the receiver covers the v.h.f., l.w. and m.w. bands. Fitted with a Garrard AT60 changer the price is 185 gn. If a Garrard Lab 80 is fitted it costs an extra 14 gn.

Hacker Constellation showing the extending loudspeaker panels.

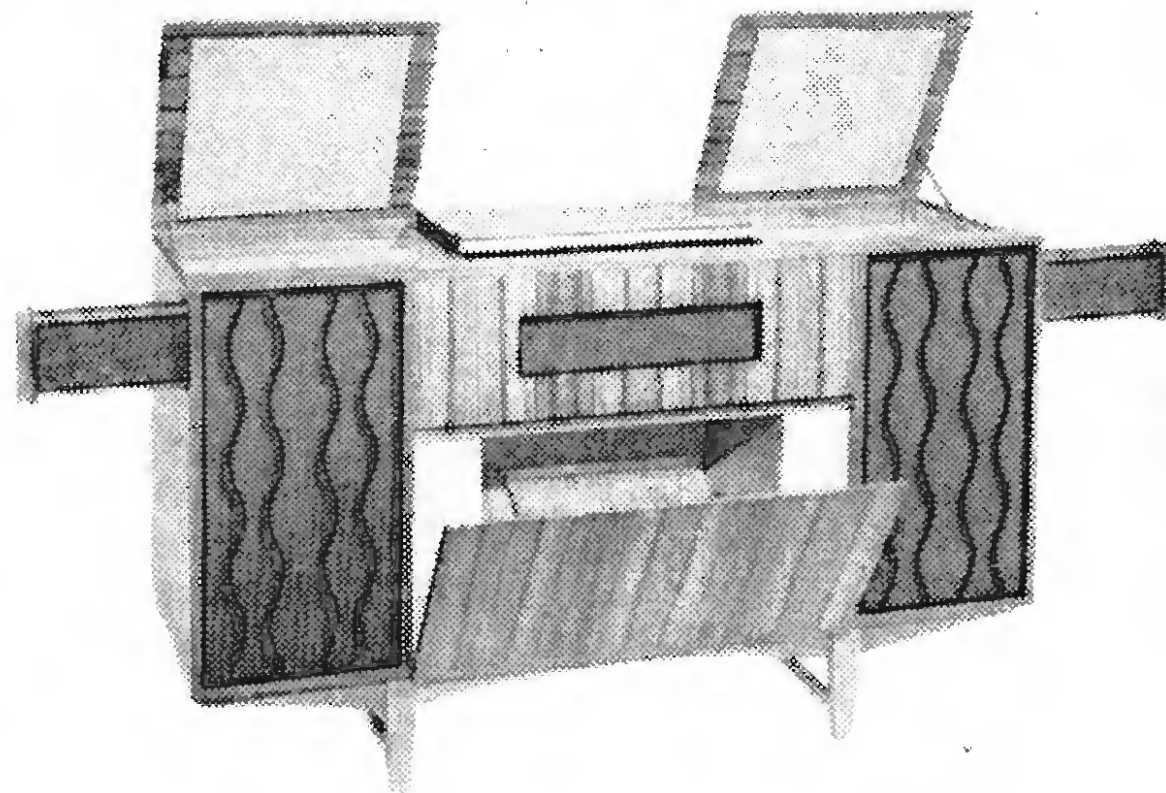

## Valradio

Large-screen pictures of 33in  $\times$  24 $\frac{3}{4}$ in are provided by the "Unitel 33" projection television receiver illustrated here (price £280). As the one-piece top and side, which contains an internal mirror, is pulled forward the screen

Unitel 33 projection television set.

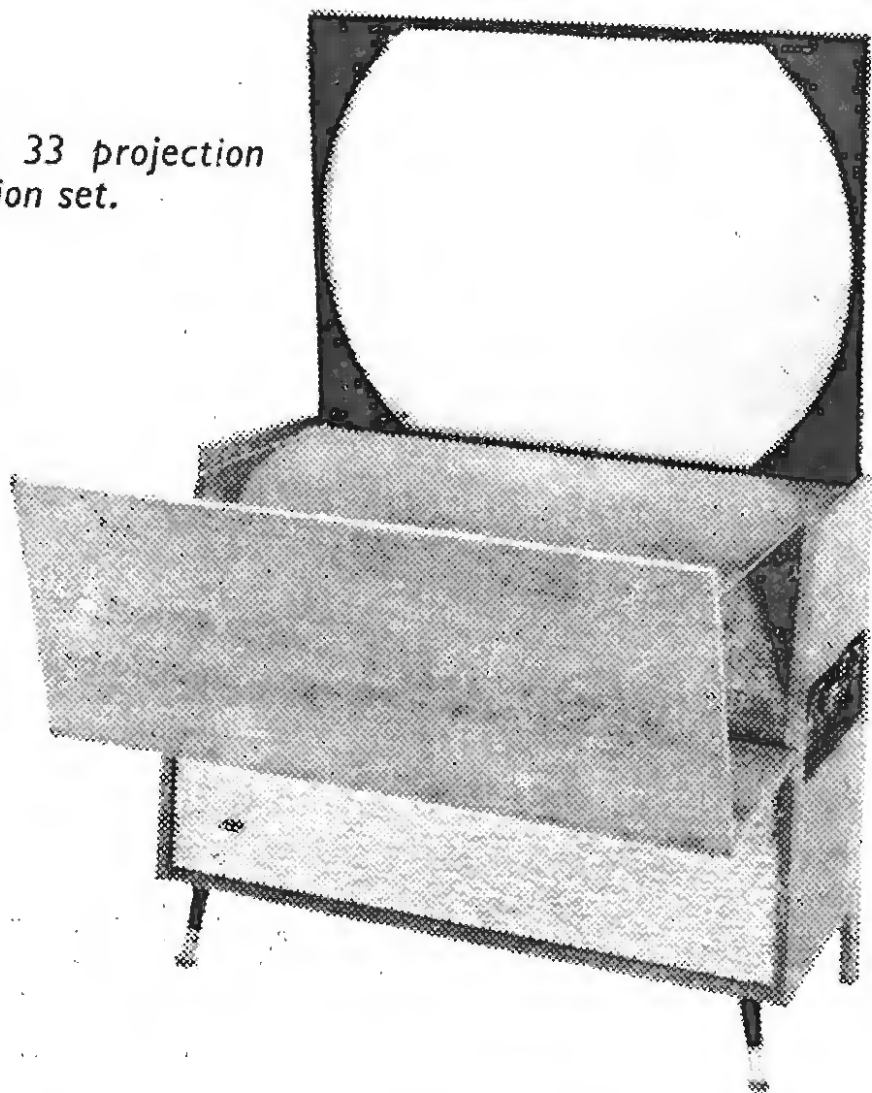

rises vertically to the viewing position and the set is automatically switched on. The "Duotel 34" (price £340) is of similar electrical design but the screen, which presents a 34in  $\times$  25 $\frac{1}{2}$ in picture, is in a separate cabinet.

The receiver covers both v.h.f. and u.h.f. television bands, has flywheel sync on both line systems, double-D scanning for maximum brightness and a 3.5-watt sound channel output. To ensure consistent performance and reduce readjustments to a minimum the mains supply is regulated to give a constant voltage  $\pm 0.5\%$  for supply changes up to 25%. Comfortable viewing distances are stated to be from 5 ft to 50 ft.

## Alba

The "Scout" Model 737 (14 gn) transistor receiver is an interesting addition to the Alba range. It is unusual in that it does not use a printed circuit! The major part of the circuit consists of two micro-miniature modules which replace the conventional i.f. and a.f. stages. Two wavebands (long and medium), with bandspread at the lower end from 195-215 m, are selected by means of

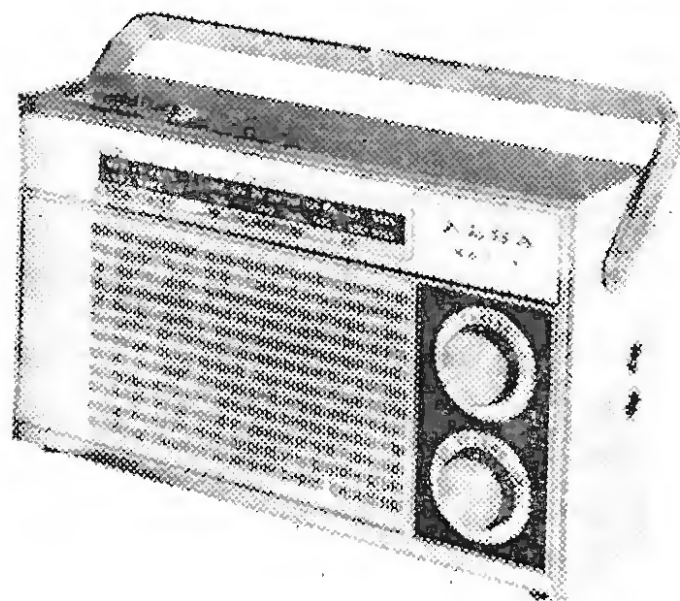

"Scout" Model 737. The cabinet is finished in leathercloth and measures 6 $\frac{1}{4}$  in H  $\times$  11 in W  $\times$  3 in D.

push-buttons. Car aerial and tape recorder sockets are provided. Other additions to the Alba range include seven radiograms and three television receivers. Of the radiograms, the "Viscount" model 9004 with stereophonic output is the most expensive at 134 gn. In addition to covering the l.w. and m.w. bands it covers 3-27 Mc/s in two bands and the v.h.f. (87.5-108.5 Mc/s) band. A bandspread control is operative on all wavebands except v.h.f. which has an a.f.c. tuning facility. Frequency response is 35 c/s to 18 kc/s and power output is 8 W per channel. A socket is provided for connecting an f.m. stereo decoder. The T1095, 19-in television receiver (68 gn complete with u.h.f. tuner) incorporates a facility on the v.h.f. tuner for permanent fine tuning adjustment of any channel in bands I and III. The control is pressed in to engage the tuning mechanism, the fine tuning adjustment is then made and when the control is released the channel tuning remains set for future use.

## Falcon

What must be one of the lowest priced of the new radiograms is this company's "Monaural," an all-transistor model covering m.w., l.w. and s.w. (15-50 m) and giving 2 watts output into the single 8in  $\times$  5in speaker. The price is 31 guineas.

Other radiograms (in which this maker specializes) all have stereophonic outputs and are based on two main chassis: a 7-valve design covering l.w., m.w., s.w. and v.h.f., and an all-transistor circuit for long- medium- and short-wave reception only. Two 8in  $\times$  5in speakers and a B.S.R. record changer are used in all models.

## Elpico

A continuously tuned r.f. stage is employed in the CR655 car radio from Lee Products. Other features of this transistor receiver, which retails at 14 gn, include a push-button tone control, its small size (2 $\times$ 7  $\times$  4 in) and a 3-watt output. It is suitable for all 12 volt d.c. systems of either positive or negative polarity and is

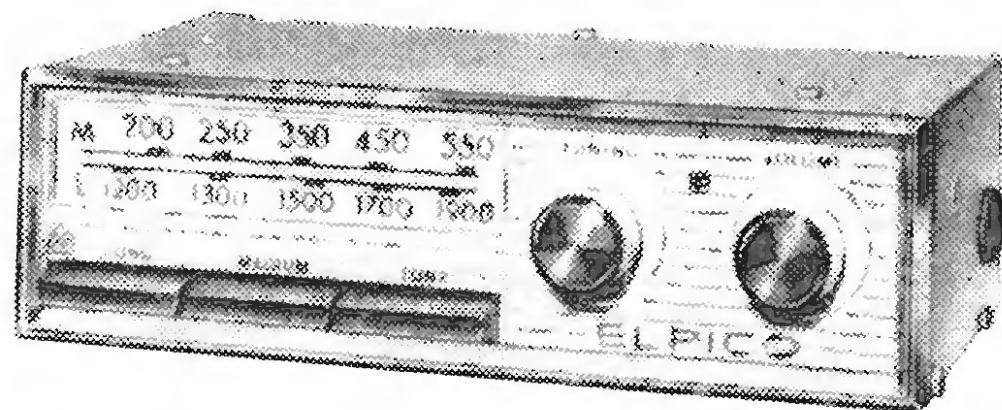

Elpico two-waveband car radio from Lee Products is suitable for systems with either positive or negative polarity.

provided with an external 7 $\times$ 4 in speaker. Flying leads for aerial, speaker and power connections are also provided along with speaker baffle and all the necessary hardware. Sensitivity is quoted to be better than 6.5  $\mu$ V in the medium-wave band and better than 12  $\mu$ V on long waves.

## Perdio

Perdio have added a transistor radiogram to their range. Called the Stereo 22, it has a BSR UA25 deck and covers the long- and medium-wave bands and 15 to 50 metres. Two 8 $\times$ 5 in speakers are fitted to the Stereo 22, which is priced at 52 gn.

## Dansette

The Princess Olympic transistor portable radiogram (19½ gn) added to the Dansette range of receivers is powered by six HP2 batteries, but a mains adaptor is available for an extra 2gn. It incorporates a two-waveband receiver, is fitted with a BSR GU7 motor and measures 12½ × 13½ × 6¾ in.

## Daystrom

Although there are no new receiver kits for the home constructor from Heathkit this year we feel that one, although not new, deserves mention. This is the GC-1U (Mk 2) general-coverage receiver covering 580 kc/s-30 Mc/s in five bands with four bandspread scales. The most interesting feature is the use of piezo-electric i.f.

transformers which do not appear to have been taken up by manufacturers generally, which is perhaps odd since alignment procedure is simplified and in many cases space would be saved. The Heathkit design eliminates two conventional transformers and two further ceramic resonators are used in place of emitter capacitors in two of the i.f. stages. This produces a sharp i.f. response and the 6dB bandwidth is about 3 kc/s.

## Ever Ready

The latest additions to the Ever Ready range of transistor portables are the Sky Baby (£11) and the Sky Queen Mk III (14gn). Both have complementary transistor output stages; the audio output of the first being 200 mW and of the second 500 mW. The seven-transistor Sky Queen employs a two stage i.f. amplifier; the Sky Baby having a single stage.

## IMPORTED SETS

**SABA** have just introduced their first transistor stereo radiogram. Called the Breisgau 16, it has an output of 12 watts per channel and the volume control is connected to a tone compensatory network which raises the bass and treble at low volume. A reverberation unit is fitted. Another all transistor unit from Saba is the Hi-Fi Studio II tuner/amplifiers. This covers the long- and medium-wave bands, v.h.f. and the 49 metre band (bandspread), and has an output of 12 watts per channel. A stereo decoder is fitted as standard and, complete with two speakers, the price is 168 gn.

**STANDARD.**—Claimed to be the world's smallest f.m./a.m. receiver is the Model SR-Q460F nine-transistor portable from the Standard Radio Corporation, of Japan. Its actual dimensions are 2½ × 2 × 1 in and it weighs 7 oz, with batteries. A 1¼ in speaker is used in this set which has a quoted output of 160 mW maximum (90 mW undistorted); an earphone socket is also provided. Coverage is from 88 to 108 Mc/s in Band II and 540 to 1600 kc/s. Retail price is 19½ gn.

**AKKORD.**—A new model in the range of West German Akkord transistor car/portables is the de luxe Pinguin 800. This is a four-waveband (40 to 50 metres on the short-wave band) set, which may be operated from either its own batteries (six U2), a car battery or from the mains, via a converter costing £5 10s. Features of this receiver include automatic preset push-button tuning for three f.m. stations, a tuning indicator and two tone controls. An extension speaker (price 3gn) is available for this 69gn set. A somewhat similar portable-cum-car radio, the 770, with the same coverage as the 800 has also just been released in the United Kingdom. This is priced at 49gn, with extension speaker, mains converter and car bracket as extras.

**TELEFUNKEN.**—While sockets are provided for stereo decoders on some of the table radios and radiograms, others are already fitted with pilot-tone decoders. One such radio is the fourteen-valve Opus Stereo tuner/amplifier. This four waveband unit has an eight-watt per channel output and an f.m. input sensitivity of 1 µV for a 26 dB signal-to-noise ratio. Other features include separate, continuously variable bass and treble controls (up to ±12dB, switched in and out of circuit by two push buttons), up to 40 dB adjustment on

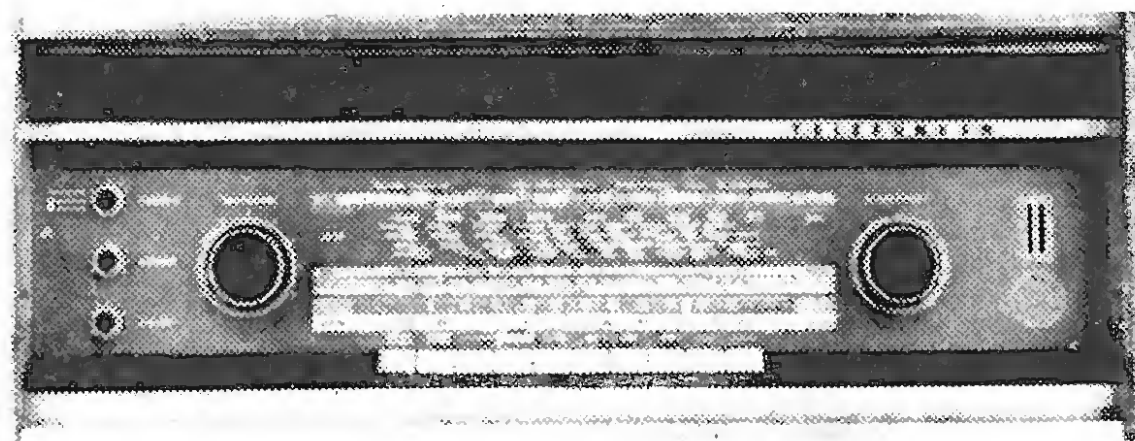

Telefunken Opus Stereo tuner/amplifier is fitted with a decoder as standard.

the balance control and a stereo indicator. Speaker enclosures, each containing a medium treble indicator (5½ × 7½ in) and a woofer (7½ × 13½ in), price 20 gn each, are available for this 99-gn tuner/amplifier.

**KÖRTING.**—Two new portable-cum-car radios have just been added to the range of transistor portables made by the West German company Körting. The cheaper of the two, the TR643 at 29½ gn, covers the long- and medium-wave bands and f.m., and the other, the TR680 (36½ gn), is a four-waveband receiver (one short-wave band) with a.f.c. A special mounting bracket is offered for the TR680 which allows the receiver to be fitted beneath the instrument panel.

**ARENA.**—Only recently introduced into Britain is the Arena range of stereo table radio receivers, tuner/amplifiers and associated equipment, made by Hede Nielsen Fabriker A/S, of Denmark. The Model T1900H mains-operated table radio employs transistors throughout and has an output of eight watts per channel. Sinus 4 × 6 in pressure-chamber speakers are used in this receiver which can be supplied with or without stereo decoder (prices 72 and 65 gn respectively).

**CLAIRTONE.**—A range of stereo radiograms using the same chassis is available; variation being in the choice of gram deck and in cabinet styling. The a.m. section of the chassis covers the long- and medium-wave bands and 170 to 345 kc/s. The latter, which partly overlaps the long-wave band (140 to 290 kc/s on this receiver) has been incorporated to allow reception of the Swiss wired broadcasting service, which is put out over the country's telephone

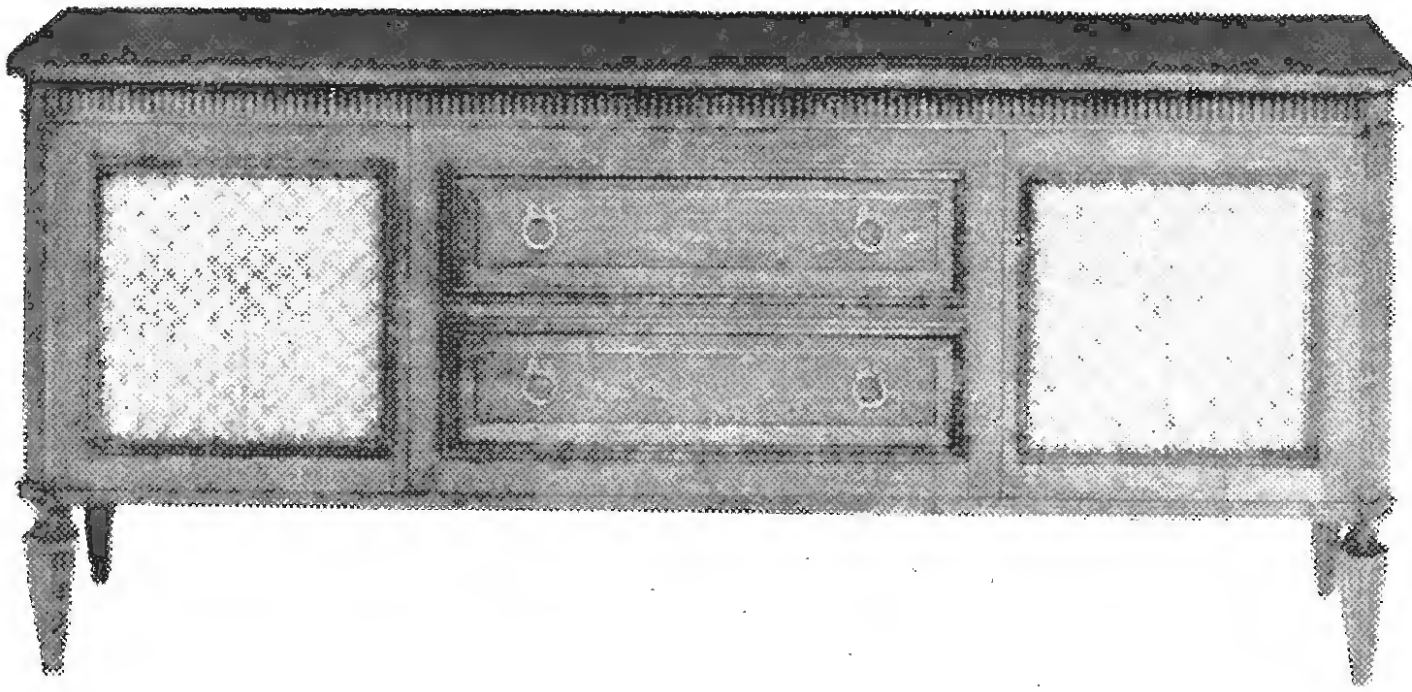

Clairtone "Duchess" stereo radiogram is fitted with a Garrard Lab 80 deck unit. Price is 385 gn.

system. (The upper part of this range of frequencies is used throughout the world for radionavigation.) The f.m. section of the receiver covers 88 to 108 Mc/s and has a stereo decoder fitted as standard. A 10 watt r.m.s. rating is quoted for each of the two audio amplifiers which require an input of 50 mV for an 8 watt output at 1000 c/s.

**UNITRA.**—A low-priced five-wave band radiogram (39 gn) from Poland has just been introduced to Britain by Daltrade. Actual coverage is 89.5 to 108 Mc/s in Band II, 6 to 10 and 11.8 to 22 Mc/s in the short-wave band, 150 to 280 kc/s long-wave band and 560 to 1600 kc/s medium-wave band. A Garrard 1000 four-speed automatic changer (fitted in this country) is employed. Five valves are used, giving an output of two watts.

**BANG & OLUFSEN.**—The latest item in the Bang & Olufsen range of products is the Beomaster 1000 stereo amplifier/f.m. tuner. Features of this shallow transistor amplifier/tuner ( $3\frac{1}{2} \times 19\frac{7}{8} \times 10$  in), which has an output of 15 watts per channel, include push-button speaker change-over switches, separate bass and treble controls, separate bass and rumble filters and a compensated volume control. A decoder unit is fitted as standard in the British version of the Beomaster 1000, which has a sensitivity of  $2 \mu\text{V}$  for 26 dB signal-to-noise ratio; full limiting at  $3 \mu\text{V}$ . Channel separation on the decoder is better than 35 dB.

**NATIONAL.**—Automatic tuning is featured in the R-1000 ten-transistor portable from National. This Japanese set employs a clockwork mechanism, which when operated sweeps the medium-wave band—in one direction—until a station is reached. Three levels of sensitivity are provided; for "DX," medium distance and local listening. Provisions are made for manual tuning. The price is 19gn.

**SONY.**—For more than a year a small portable television receiver has been on the cards from Sony. It has now arrived, a nine-inch model that weighs only 12 lb, but it will not be in the shops until later this year. Known as Model TV 9-306UB, it is a dual-standard receiver covering Bands I, III, IV and V and will operate from either the mains, a car supply (12 volt) or from a re-chargeable battery pack (12gn). Sockets are provided for an external aerial, for tape recording and for earphones. The price is 85 gn.

**BLUE SPOT.**—Two Blue Spot (Blaupunkt) car radios with v.h.f. coverage appeared this year. Both receivers offer multi-wave band coverage. The higher priced set, the Köln ATR (78 gn), has an automatic station finder, which utilizes an electric motor. A sensitivity switch is provided which allows the station finder to over-run the lower strength stations. Manual tuning is also provided on this German

receiver which covers the long- and medium-wave bands and 87 to 104 Mc/s in Band II. In addition, a short-wave band covering 5.9 to 6.35 Mc/s is provided on the other receiver, the Frankfurt (52 gn).

A transistor converter suitable for any Blaupunkt car radio is offered at 18 gn for the short-wave listener. Known as the KV 900 adaptor, it is easily fitted beneath any installed receiver and derives its power from the main receiver. Wave-band coverage is 13, 16, 19, 25, 31, 41, 49, 60 and 90 metre bands; selection is by push-button. The medium-wave scale of the main receiver is used for an indication of tuning.

Many "made-to-measure" installation kits for British cars are offered along with numerous accessories, from a second speaker to a voltage divider for 24 volt systems.

**SHARP.**—A world time chart is contained in the lid of the Model FV-1700 "Intercontinental" transistor receiver. This Japanese set covers 1.6 to 26.5 Mc/s in the short-wave band (split into three), the long- and medium-wave bands and 86.5 to 108 Mc/s in Band II. Operating from 12 volts, the

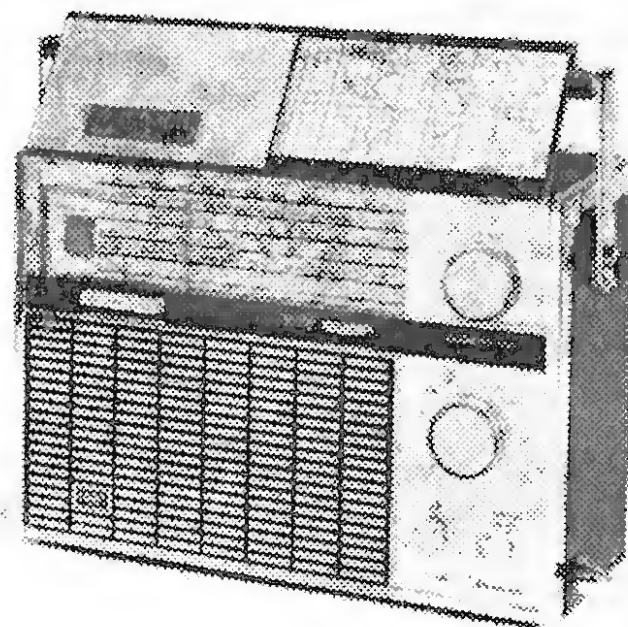

Sharp Model FV-1700 Intercontinental receiver contains a b.f.o. for c.w. listening.

FV-1700 may be used in a car, sockets being provided for connection to an external power source and car aerial. A  $6 \times 4$  in speaker is used and the maximum output of the receiver is quoted as one watt (0.7 W undistorted). Features include a b.f.o. for c.w. reception, a.g.c. and a.f.c. Retail price is 69 gn

**NORDMENDE** have introduced a baby brother to their 15-waveband Transita-Globetrotter named Globetraveler Jr (in all countries other than U.S.A. and Canada where it is called Transita TS de luxe). This covers five wavebands with bandspread tuning on the 49 metre band and can be used as a car radio; output is quoted as 4 watts when operated from a car battery. Features of this set include an internal  $5 \times 7$  in speaker, a bass control and a continuously variable treble control. The dimensions are  $8 \times 11 \times 3\frac{3}{4}$  in, and the price 49 gn.



# A Non-resonant Loudspeaker Enclosure Design

By A. R. BAILEY,\* M.Sc.(Eng.), Ph.D., A.M.I.E.E.

—USING ACOUSTIC TRANSMISSION LINE WITH LOW-PASS FILTER CHARACTERISTICS

**O**VER the years, the design of loudspeaker units has progressed steadily until some are now available with very good performance capabilities. In particular, the advent of expanded polystyrene as a cone material has greatly reduced the distortions due to cone break-up.

Unfortunately, the design of loudspeaker cabinets has not kept pace with these developments, and there is little doubt that many enclosures now introduce more coloration than that produced by good loudspeakers. The loudspeaker enclosure to be described was developed to give as little coloration as possible, but to understand its evolution it is necessary to return to basic principles.

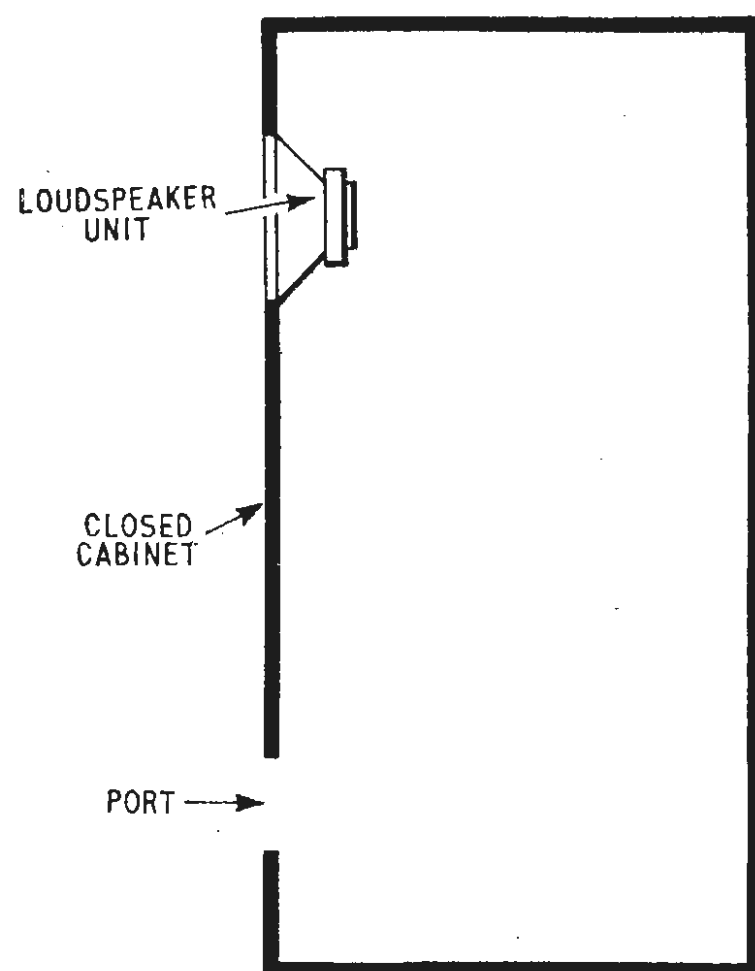

Fig. 1. Section through bass reflex cabinet.

By far the largest number of current loudspeaker cabinets are based on the "bass reflex" cabinet design<sup>1</sup>. This is shown in Fig. 1 as a sectional view. This cabinet appears to have only a relatively short path-length between the back and the front of the cone and would therefore be expected to give relatively poor l.f. response. In fact the response at low frequencies can be quite large, this being due to the cabinet having a Helmholtz air-column resonance at about the lowest frequency being reproduced. In the reference given previously, the theory is well explained.

Unfortunately, this resonance in the cabinet causes coloration in the bass output of the system. This "ringing" on bass transients can be very noticeable, particularly on such instruments as string bass.

In addition the cabinet itself is frequently unlagged and consequently the sound is still emerging long after the original signal has stopped. Very heavy lagging is

\*Bradford Institute of Technology.

necessary to stop this effect and in so doing the cabinet "Q" is reduced so that the bass reflex action is lost.

Sine-wave testing does not necessarily show up the defects of a speaker system. Rapid cut-off at the edges of a flat response can make it sound far worse than a slower rate of fall at the edges of a system with apparently a poorer bandwidth. This is shown in Fig. 2.

The effect of the abrupt change in slope of the amplitude/frequency characteristic is to give "ringing" at the frequency where the slope change takes place. This effect is unavoidable and is the necessary price to pay for the extension of bandwidth by the use of resonance effects. It is for this reason that loudspeaker systems can sound very "boomy" in the bass, even though the measured amplitude response shows no resonant peaks.

One method of testing that has not apparently been widely used is that of impulse-testing of loudspeaker cabinets. This method is very powerful and is described later on. For the moment it is sufficient to state that it confirmed that normal loudspeaker enclosures are not very good.

It is now apparent that it is the sound waves produced at the rear of the cone that have to be absorbed if delayed output and resonances are to be avoided.

Acoustic labyrinths<sup>2</sup> have been used in the past in an attempt to "lose" the sound down multiple paths. Such an enclosure is shown in Fig. 3, but the size needed is excessive. Unless there is adequate internal lagging, then these cabinets will also possess pronounced energy storage and the consequent lack of sound clarity.

## Transmission line approach

The only safe method of removing the rear cone sound energy is by transmitting it down an infinite transmission line. This is obviously impracticable so the nearest approximation was examined.

If a transmission line for acoustic waves is filled with

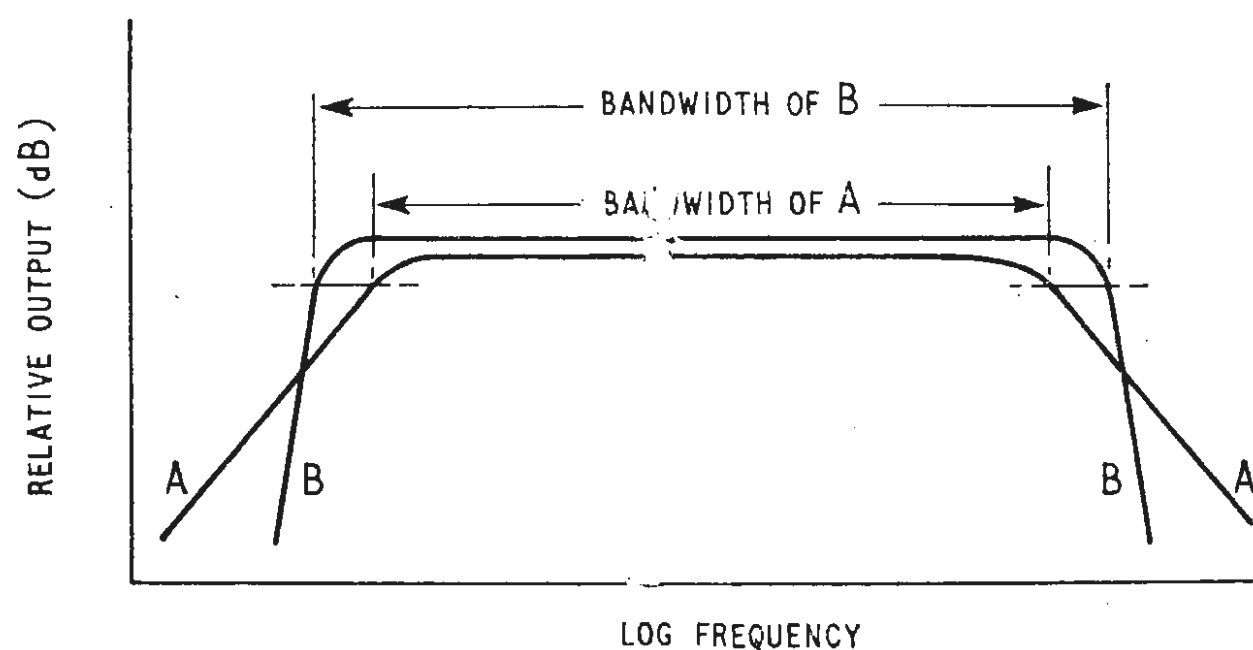

Fig. 2. Response curves having different transient responses.

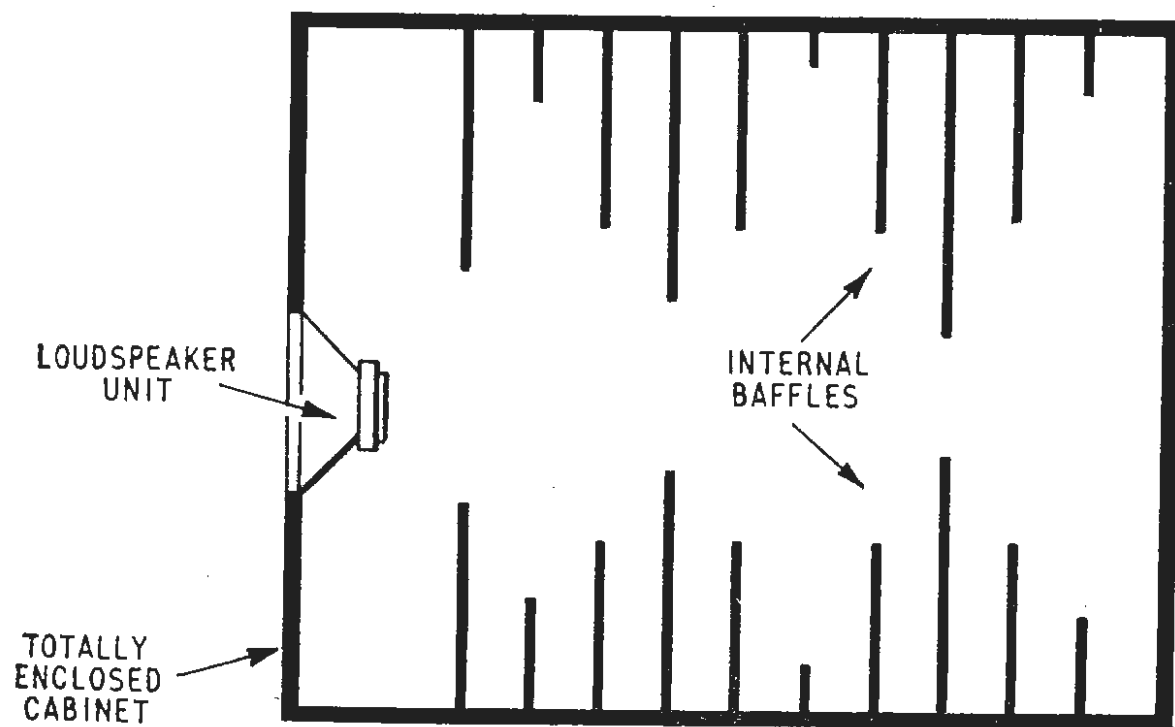

Fig. 3. Section through acoustic labyrinth cabinet.

a light acoustically-resistive medium, then the transmitted wave will be rapidly attenuated. After a certain distance the wave will be so weak that a blockage of the line will give only a minute reflected wave back to the speaker cone. The magnitude of the reflected wave can be determined by the standing-wave ratio immediately behind the speaker.

The choice of acoustic absorbing material will greatly affect the final performance so an initial investigation was made into the reflecting properties of various acoustic transmission line terminations. Many materials including glass fibre were tried, but the best results were obtained from long fibre wool. This gave a remarkably good absorption down to quite low frequencies. A typical set of the curves obtained is shown in Fig. 4.

For practical purposes a long pipe is not desirable so experiments were then made with a folded pipe of total length of about 8ft. This was built as shown in Fig. 5, the far end of the pipe having a pivoted flap so that characteristics could be taken with both open and short-circuit terminations. The results proved most interesting.

With the port closed the loudspeaker gave a very good

performance with a slightly weak bass response. Sine-wave testing confirmed that the bass response fell by several dB below 60 c/s although the cone amplitude doubled for a halving of the input frequency. The trouble was finally traced to diffraction effects, the radiated wave-front changing its polar response at low frequencies. The effective bass response could be changed very markedly by positioning the cabinet away from a wall. The bass response then fell even further due to the increased diffraction at low frequencies. For test purposes a plain wall backing was used.

Opening the port had two effects. First, the bass response was improved to become approximately flat and secondly the cone excursion was greatly reduced between 30 and 50 c/s. The bass improvement was due to the line length being such that the delayed bass wave from the line was in phase with that radiated by the front of the cone. Also as the bass frequencies were radiated from two spaced sources, the diffraction effects would be reduced.

As the wool-filled line acts as a low-pass filter, the radiation from the vent cuts off before cancellation can occur at the higher frequencies. The rapid cut-off of this acoustic line is shown in Fig. 6. This shows the sound pressure at the port end of the line with the port closed.

### Impulse response

As the performance so far appeared to be satisfactory it was decided to investigate the impulse response of the loudspeaker cabinet. The square-wave testing of loudspeaker units had previously shown that it was not possible to generate a good square-wave of sound pressure, let alone an impulse. Several mechanical methods were then tried but none proved to be really satisfactory. The author is therefore indebted to his colleague, R. V. Leedham, for suggesting the use of exploding wires as a standard impulse source.

Exploding wires proved to be a delightfully simple and accurate method of generating an acoustic impulse.

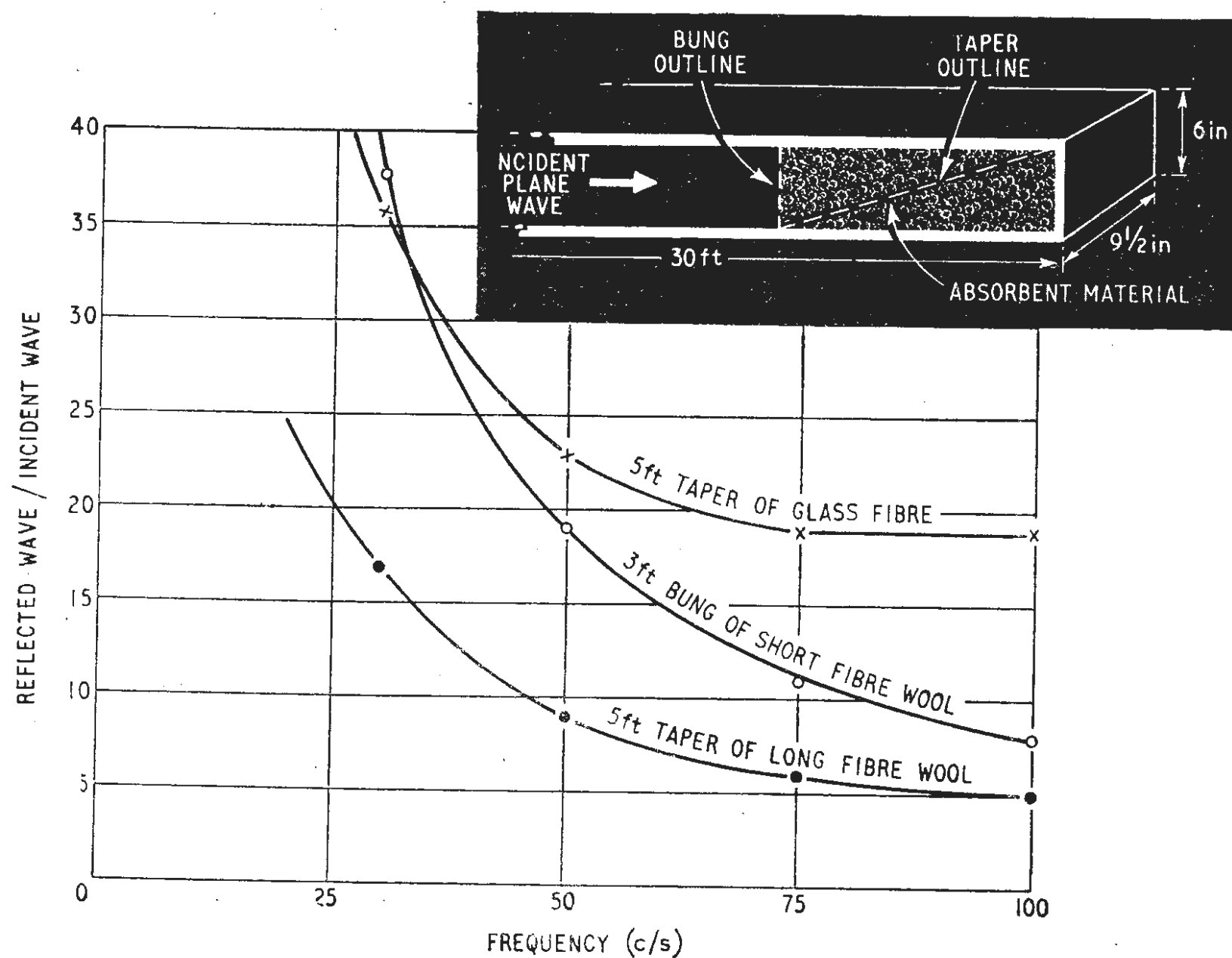

Fig. 4. Reflection characteristics of acoustic absorbents.

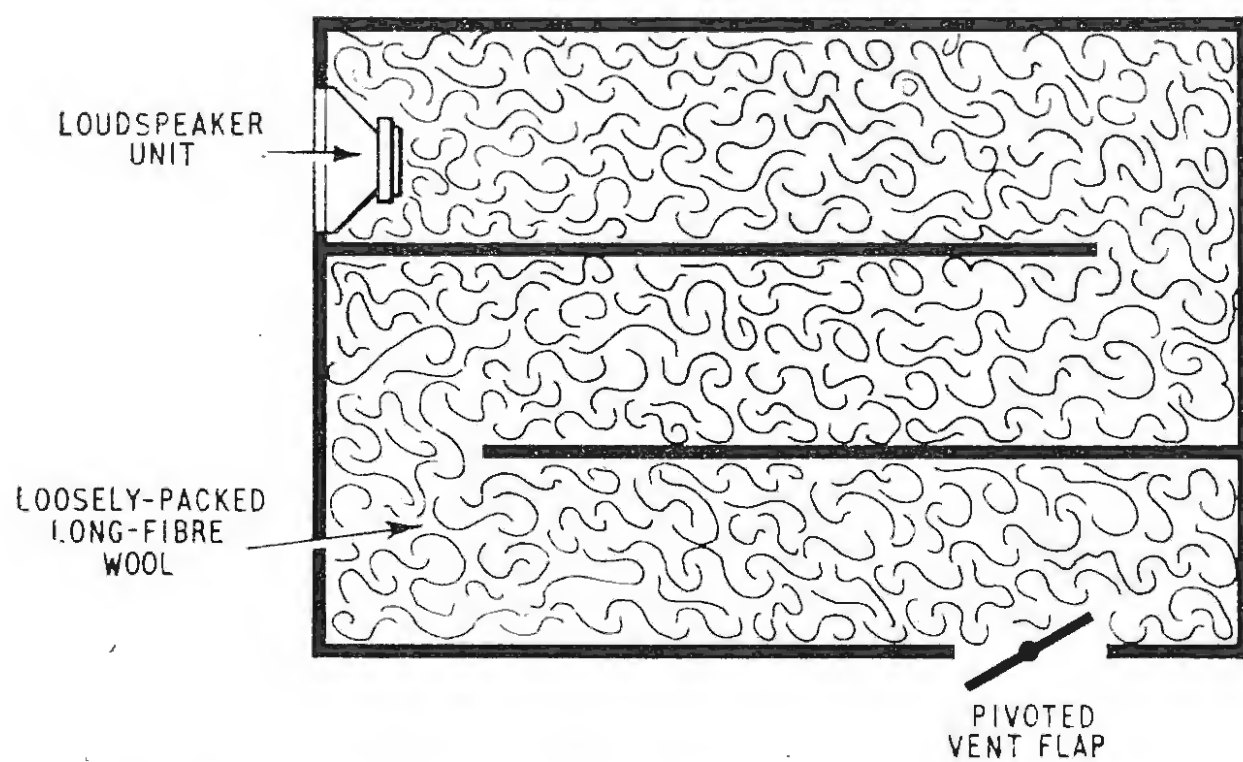

Fig. 5. Experimental acoustic transmission line cabinet.

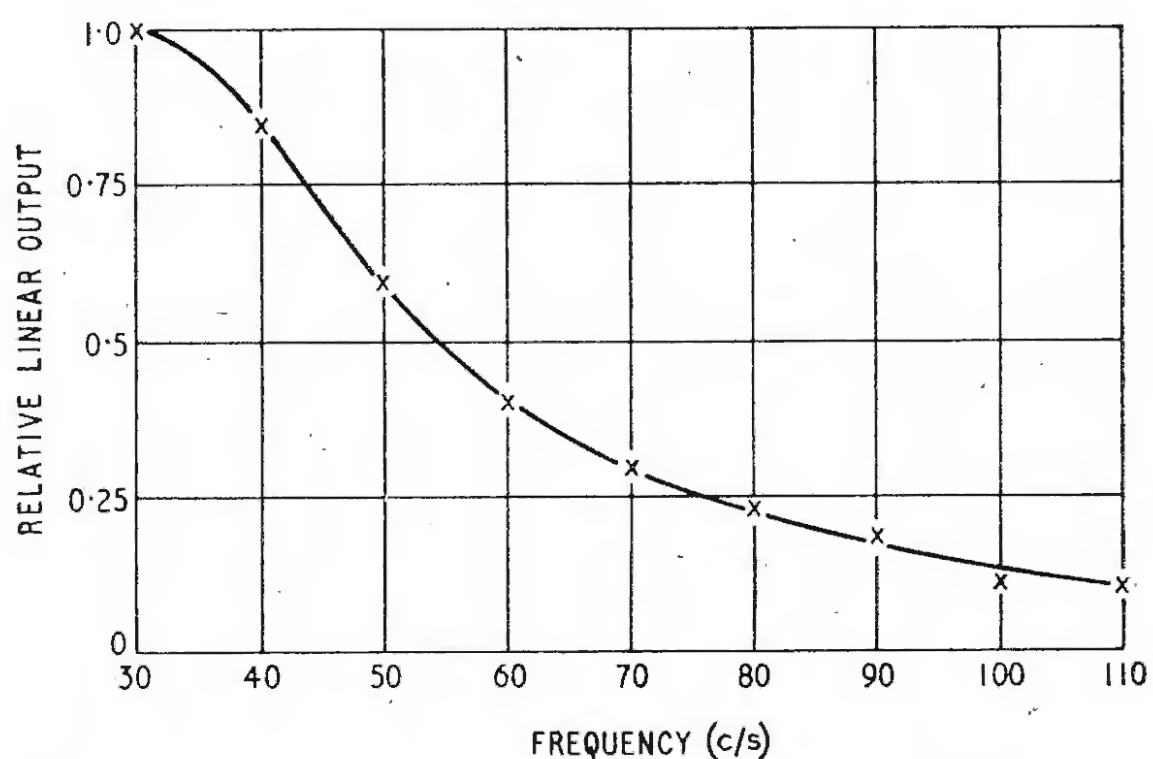

Fig. 6. Sound pressure in closed vent of experimental cabinet.

Basically the method involved discharging a low inductance capacitor of high value (1000  $\mu$ F) charged to about 250 V through 1 cm of 40 s.w.g. tinned copper wire. The wire is vapourized almost instantaneously and the acoustic impulse produced had a rise time well into the supersonic region. Spark-generated impulses could have been used, but a high-voltage source is necessary of considerable stored energy if an adequate impulse is to be produced. As exploding wires were less lethal experimentally and only needed standard power supplies, the use of a spark source was not pursued.

The measuring microphone used had a working bandwidth of 30 to 10 kc/s and was used inside the cabinet at a distance of 18in from the exploding wire source. The exploding wire was operated at the position where the loudspeaker would be used, the loudspeaker opening being blanked off.

The results appear in Fig. 7a, the initial impulse being just discernible. The results were felt to be very creditable, the large damped oscillation being the flexure of the  $\frac{3}{4}$ in blockboard immediately behind the exploding wire. The experiment was then repeated with a bass-reflex cabinet of identical size having a port area of some 24in<sup>2</sup> and unlagged internally. The results were markedly dissimilar. Acoustically a much louder hollow explosion could be heard and the microphone pickup showed a far larger spurious output for a much longer time. This is shown in Fig. 7b, the sensitivity and time scales being identical with that of the previous test.

The cabinet was then lagged internally with sound absorbent and the test was repeated. The result is shown

in Fig. 7c, the resonance obviously being better damped but still far worse than the line type of cabinet.

Listening tests proved that the cabinet had a "cleaner" sound than the bass reflex type, the effect of the line being very noticeable in its lack of coloration on speech. Transient response was definitely better on the line speaker, the sound being more "tight" and natural.

For obvious reasons it is preferable to have the long axis of the loudspeaker in the vertical plane. The cabinet ducting arrangement was therefore rearranged and one commercial form is as shown in Fig. 8. To make the most of the cabinet it is obvious that the loudspeaker units must not possess large colorations of their own. The units quoted give very good performance although other equally good units may be available. The cross-over frequency used is 1500 c/s.

The frequency-amplitude response of the complete loudspeaker system is shown in Fig. 9. The rate of

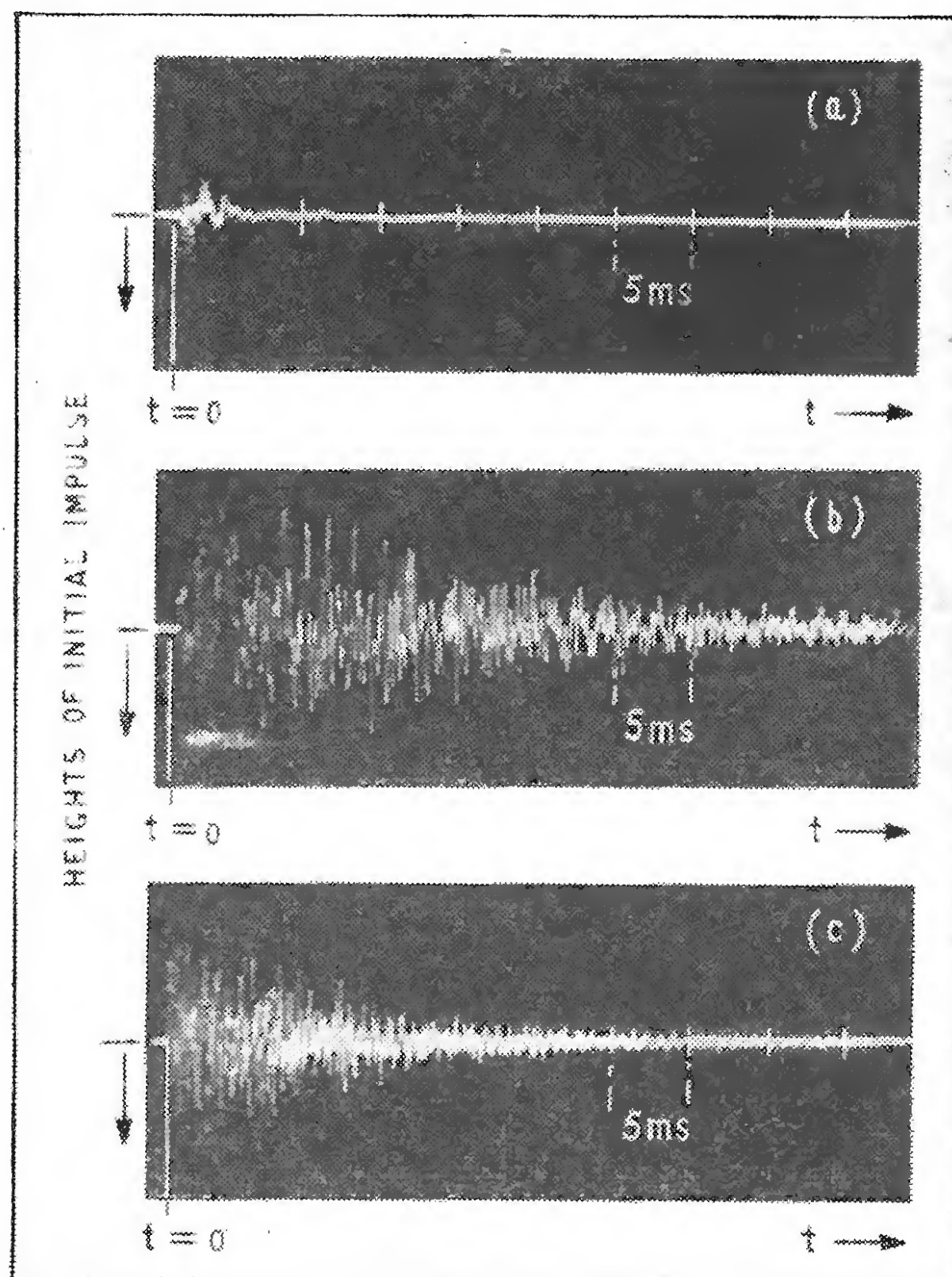

Fig. 7. (a) Impulse response of acoustic transmission line loudspeaker cabinet. (b) Impulse response of bass-reflex cabinet identical in volume to (a). (c) Impulse response of bass-reflex cabinet with internal lagging.

fall at the low frequency end is creditably slow and far better than the majority of systems in use. It is not unknown for rates of cut-off to be as high as 18 dB per octave and to start very rapidly. This gives rise to a "heavy" bass effect that some people prefer; it is, however, not natural.

The bass resonant frequency of the speaker unit is below 15 c/s in the enclosure (about 30 c/s in free air) and quite well damped, so this will have no noticeable effect on the output. As the acoustic loading of the pipe

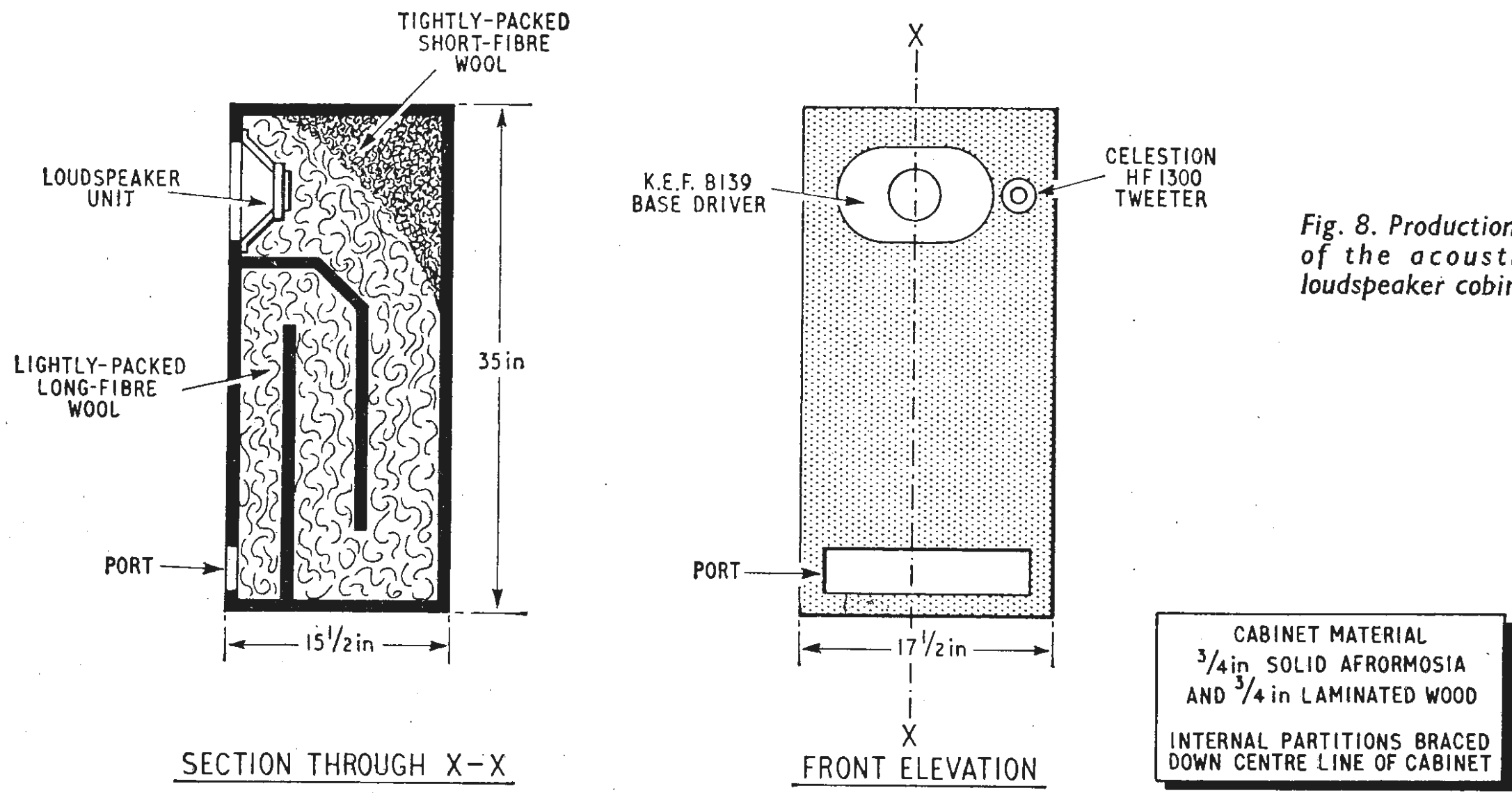

Fig. 8. Production version of the acoustic-line loudspeaker cabinet.

is, therefore, dominating the speaker unit, the low-frequency waveform will be better as the non-linearity in the loudspeaker unit suspension will be swamped by the linear acoustic loading.

The final subjective tests were very good. The sound quality is effortless and natural. At first hearing the bass sounds to be deficient but extended tests show that this is not so, it is merely that one has been conditioned to hearing resonant bass. The overall effect is surprisingly unexciting—only natural. In over a year's use of the system the author has noted, however, that musical listeners were very impressed with the result.

**Practical Points**

The cabinet design is not critical, and many variations are possible. The only cardinal point is that of keeping the pipe area above that of the cone. A rather strangled result can occur if an attempt is made to save space by restricting the pipe area much below that of the speaker cone. It must also be noted that a poor speaker does not usually sound much better in a good cabinet as the speaker deficiencies dwarf the improvement.

The application of the principle of the design is the subject of a Patent, but there is no restriction, of course, on private individuals making cabinets for their own use. For the amateur constructor the following points may be of use:—

(1) The cabinet should be made of thick acoustically dead material, chipboard being generally better than plywood. Due to the absence of high internal pressures

and the absorbing effect of the wool, the cabinet thickness and bracing are not as important as in the case of the bass-reflex.

(2) Acute bends in the pipe should be arranged to occur as far from the loudspeaker cone as possible to reduce the magnitude of standing waves due to reflections.

(3) The wool should be of long fibre length and packed fairly loosely, about one pound to every two to three cubic feet. The grade of wool is still being investigated for the optimum specification.

(4) Either spray the wool with mothproofer or take other suitable action or the cabinet performance may suffer from an ageing process.

The author has constructed several different cabinets of totally different sizes and geometry, and apart from narrow pipes and badly angled bends the performance has been remarkably similar. In fact a low resonance 4in unit has been used effectively and gave a good output at 35c/s. The power handling capacity was, however, limited.

**Acknowledgements.**—In conclusion the author would like to thank Radford Electronics Ltd. for permission to give the details shown in Fig. 8. Also thanks are due to R. V. Leedham and other colleagues for their help and criticism.

**REFERENCES**

- 1. "Sound Reproduction" G. A. Briggs, p. 62.
- 2. *Ibid*, p. 56.

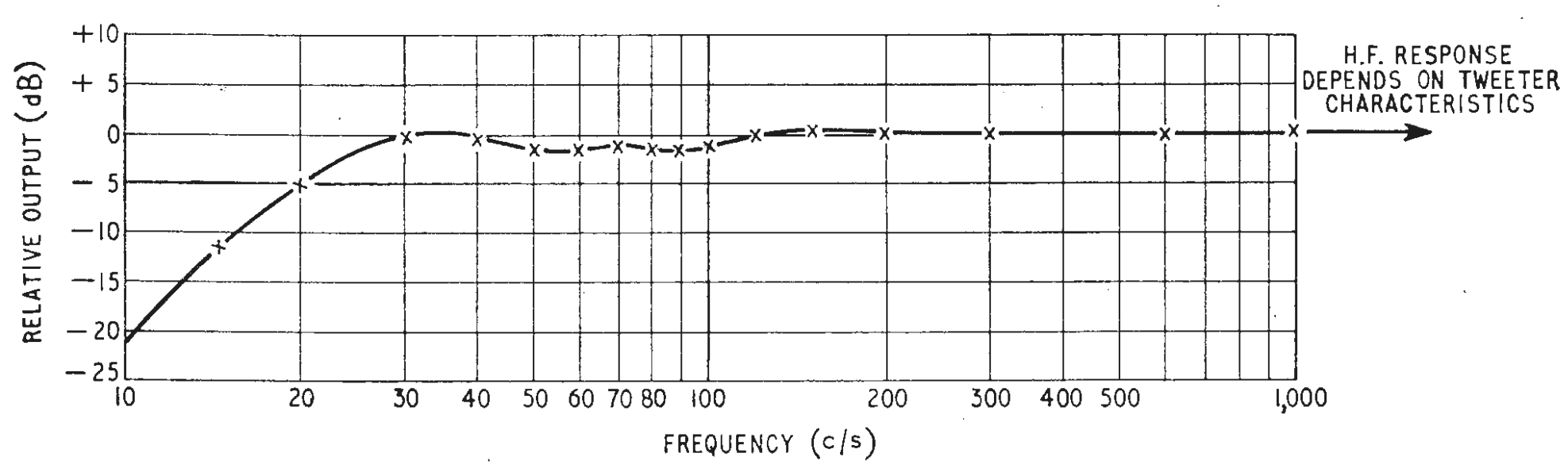

Fig. 9. Overall sine-wave response of Fig. 8.

# WORLD OF WIRELESS

## V.H.F. or U.H.F.? 405 or 625?

LORD HILL, chairman of I.T.A., said recently, "It is clear that u.h.f. broadcasting is here to stay, but it may not be going to make the complete take-over bid that once seemed likely. Expert opinion has altered somewhat since 1962 when the Government White Paper proposed to change, by stages, the existing 405-line services to 625 lines. It now appears that there are technical and financial difficulties in duplicating the services in u.h.f. Some minds are turning to the possibility of changing to 625 lines *within* v.h.f. It seems clear that, whatever its merits, the u.h.f. system could not provide the same total coverage as v.h.f.; and then, of course, u.h.f. requires so many more stations.

"If a suitable method of conversion to 625 could be found, several advantages are argued for keeping ITV and the BBC-1 in v.h.f. First, it would avoid the great and continuing expense of duplication; second, it would avoid using valuable air space which may be needed for future services. Third, it would give the television industry a firm technical basis on which to plan their operations for the foreseeable future."

Lord Hill went on to say, however, that "it rather looks as though the 405-line services may become a permanent feature of British Television and if this were so, then there might be grounds for reconsidering the original idea that only the 625-line services should have colour."

The industry's latest statement on this subject stresses the need for one standard (625 lines) for all services whether v.h.f. or u.h.f. B.R.E.M.A. in its statement acknowledges the difficulties in accomplishing the changeover to the new standard but it adds "these are not sufficient to justify a reversal of this decision," as has been expressed in some quarters

## Higher-Power Satellites

DIRECT broadcasting of sound and television programmes from satellite repeater stations should be a reality within 10 years, according to R. M. Bentley, manager of the "Early Bird" communications satellite project for Hughes Aircraft Company. Outlining his company's present and future work in this field at the INEL 65 exhibition in Basle (p. 509), Mr. Bentley mentioned particularly a new communications satellite under development, the HS307. Weighing 600 lb and using a 600 W solar cell power supply, this satellite will have an e.r.p. of 7.5 kW (using a high-gain electronically "despun" aerial) and a capacity of 5,000 voice channels or 12 television channels. Hughes will also have a new low-cost (£350,000) fixed aerial ground station in operation in Arkansas by the Spring of 1966.

## Amateur Radio Growth

THE 21 European national member societies of the International Amateur Radio Union now muster between them more than 150,000 members, of whom 40,000 hold transmitting licences, but by no means are all transmitters members of societies. Topping the list is the Radio Sports Federation of the U.S.S.R. (RSF) with 71,000 members followed by the Yugoslav society (SRJ) with 24,000 members. Both societies have a very large number of young members who pay only a nominal subscription. There are 10,500 amateur transmitting stations in the U.S.S.R. and 3,600 in Yugoslavia, but of these only 3,500 and 950 are members of the respective societies.

The Federal German Republic with 11,465 and the United Kingdom with 11,250 have the highest number of licensed stations among the western group of nations. Numerically the German society (D.A.R.C.) with 15,700 members (8,300 of whom are licensed) is ahead of the Radio Society of Great

On October 8th the opening of the 620ft **Post Office Tower** in London will be marked by the issue of 3d and 1s 3d stamps featuring the tower. The design of the 3d stamp shown in the illustration uses two shades of blue and yellow and shows the tower rising from a symbolic foreground of Georgian type houses which are a feature of the immediate vicinity



Britain with 12,750 members, of whom 7,700 are licence holders.

Looking beyond Europe, the Japanese Amateur Radio League with 16,100 members ranks second only to the American Radio Relay League with its 88,000 members. The U.S.A. with 255,000 amateur stations and Japan with 38,000 are world leaders followed by Germany (11,465), the United Kingdom (11,250) and Canada (10,500). At the other end of the list we have Syria (9), Iceland (10), Burma (25), Lebanon (25), Greece (26) and Jamaica (32).

The world total of licensed amateur stations is 498,000—by far the largest number of stations in any of the communication services recognized by the International Telecommunication Union.

## American Subscription TV

R.K.O. GENERAL, operator of the only American subscription TV station (Hartford, Conn.), has obtained options on the Zenith Radio Corporation's Phonevision system for operation in New York City, New Haven, Philadelphia, Washington D.C. and San Francisco. Exercise of these rights will depend upon assessment of results from the Hartford station and approval of the Federal Communications Commission. The Hartford station has been in operation as an experimental subscription TV station for three years, and recently the F.C.C. extended the licence for a further three years to give the station the opportunity to increase the number of subscribers. Programmes do not contain advertisements and are transmitted as scrambled u.h.f. signals and are unscrambled by a device fitted to the receiver.

The **Granada Lectures** on problems of communications in the modern world arranged by the British Association for the Advancement of Science in collaboration with Granada Television will this year be held on three successive Wednesdays in October in the Guildhall, London. On the 13th Alistair Cooke will speak on "transatlantic communications," on the 20th Dr. J. B. Rhine's lecture is entitled "E.S.P.—what can we make of it?" and on the 27th Admiral H. G. Rickover, U.S.N., will discuss "a humanistic technology." Tickets are obtainable free from the British Association, Sanctuary Bldgs., Gt. Smith St., London, S.W.1, or Granada, 36 Golden Sq., London, W.1.

The new members of the board of the **Electronics Division** of the I.E.E. are: R. J. Clayton (G.E.C. Electronics) who is a vice-chairman, Prof. J. Brown (University College, London), Dr. F. G. Heath (I.C.T.), G. King (Standard Telecommunications Laboratories), C. A. Marshall (*Systems & Communications*), Dr. W. H. Penley (Ministry of Aviation), and J. B. Smith (Ferranti).

**Radio Show Special.**—The Pye/Ekco group have fitted out a thirteen-coach train as a travelling radio show. One coach contains a fully operational local broadcasting station, another supplies 405- and 625-line pictures to other coaches, and another contains working demonstrations of radio-telephones and other communications equipment. Remaining coaches display the full range of Pye/Ekco domestic equipment. Cities in which the train will stop are Birmingham, Sept. 29th-30th; and—during October—Manchester, 1st-2nd; Glasgow, 4th-5th; Newcastle, 6th-7th; Nottingham, 8th-9th; and Norwich, 11th-12th. Free admission to the train is between 10.00 and 21.00.

A recently issued 24-page booklet, **Careers with Instruments**, broadly describes the various fields in which instruments are used together with comprehensive details of the different levels of technical education and the careers to which they lead. The booklet, price 2s 6d, is available from the Society of Instrument Technology, 20 Peel Street, London, W.8.

The Society of Environmental Engineers is holding an exhibition and symposium, "**Environmental Engineering and its Role in Society**," at the Imperial College, Exhibition Road, London, S.W.7, during April 19th-21st, 1966. Further details are available from S.E.E., Radnor House, London Road, Norbury, London, S.W.16.

A changed specification for **enamelled and rayon covered conductors** has been issued by the British Standards Institution under the title "B.S.3902 Enamelled and rayon covered copper conductors (oleo-resinous enamel), Part 1 Round wire." The new specification replaces part of B.S. 2479 which is being withdrawn because the rayon it specified as an alternative to natural silk is no longer available. The publication, price 6s, is obtainable from British Standards Institution, Sales Branch, 2 Park Street, London, W.1.

**Amateur transmitting licences** in the U.K. totalled 13,531 at the end of June. There were 13,130 "A" sound licences including 1,893 for mobile operations, 236 "B" sound licences (for telephony operation above 420 Mc/s) including 2 for mobile operation, and 165 television licences.



**Madam Popova**, daughter of the famous Russian radio inventor Alexander Popov, is curator of the museum of radio in Leningrad—the city in which Popov gave in 1895 his first practical demonstration of radio telegraphy. (The city was then St. Petersburg of course.) Here she talks to Daniel Maillard, general manager of Société de Diffusion de Radio-Télévision, the French company which sells Ducretet Thomson domestic receivers. Eugène Ducretet was a contemporary of Popov's and collaborated with him on radio experiments for a period at the end of the last century.



A scholarship is being awarded annually by Dynamco Instruments Ltd. to allow a suitable candidate to attend a post graduate course in electronics at Southampton University. To qualify, a candidate should possess a degree or equivalent qualification in physics or electrical engineering although other qualifications, in mathematics for example, may be acceptable. The illustration shows the recipient of the 1965-66 scholarship, Mr. Charles Bockett-Pugh, who recently gained an honours physics degree from the new St. Catherine's College, Oxford.

**Acoustics Congress.**—The 5th International Congress on Acoustics was held from 7th-14th September at the Palais des Congrès, Liège, Belgium. An account of the proceedings will appear in the November issue. The 6th Congress will be held in Tokyo during the latter part of August, 1968.

**Navigation Satellites.**—The use of the forthcoming series of NASA Applications Technology Satellites (A.T.S.) was discussed at a meeting of the American Astronautical Society held recently in San Francisco. Mr. Leonard Saffe, NASA Communication and Navigation Programme Director, referred to a navigational system whereby satellites in medium-altitude and synchronous orbits would provide information on the position of ocean craft to ground computer stations. It was also suggested that experiments will be undertaken enabling small ground stations to have radio access to satellites.

The sixth in the series of international conferences on **microwave tubes** will be held at Cambridge University from September 12th-16th next year. The last was in Paris in 1964. Its title has been changed to Conference on Microwave and Optical Generation and Amplification and it is being organized by the I.E.E.

**Steerable Aerials.**—A forum for the exchange of ideas and information between those responsible for the design, construction and use of large steerable aerials will be provided by a conference being organized for June 6th-8th next year. The sponsors are the I.E.E., I.E.R.E., I.E.E.E., I.Mech.E. and I.Structural E.

The Post Office recently issued the **ten thousandth licence for radio-controlled models**. These licences, which were introduced in 1954 under the Wireless Telegraphy Act of 1949, cost £1 and are valid for five years. Frequencies allocated for radio control of models are 26.96-27.28 Mc/s and 458.5-459.5 Mc/s.

**Which Switch?**—Designers and constructors are reminded that Specialist Switches Ltd., of 23 Radnor Mews, London, W.2 (Tel.: PADDINGTON 8866), supply single rotary switches to any specification.

# PERSONALITIES

**Prof. A. L. Cullen, O.B.E., Ph.D., D.Sc.(Eng.),** who has occupied the chair of electrical engineering in the University of Sheffield since it was created in 1955, is the new chairman of the Board of the I.E.E. Electronics Division. After graduating at Imperial College, London, in 1940, Dr. Cullen joined the staff of the Royal Aircraft Establishment,



*Prof. A. L. Cullen*

Farnborough. From 1946 until his appointment at Sheffield he was at University College, London, first as a lecturer and later as a reader in electrical engineering. In 1959 he was awarded a grant of nearly £4,000 from the Paul Instrument Fund for the construction of a detector in which radiation pressure is used to convert a microwave signal to an audio or intermediate frequency. For the past year he has been visiting professor at the University of California, Berkeley. Prof. Cullen is joint author with Prof. H. M. Barlow of the book "Microwave Measurements."

**J. M. C. Dukes, M.A., D.I.C., A.M.I.E.E.,** has joined A.C. Cossor Ltd. as technical director. For the past six years he had been with the Plessey Company, first as technical manager of



*J. M. C. Dukes*

the Telecommunications Division and since 1962 chief engineer of the Electronic and Equipment Group. From 1947 until joining Plessey Mr. Dukes was with the Standard Telephones & Cables group. In 1961 he was elected a member of the Technical Committee of the British Space Development Company of which Plessey is a sponsoring company.

**A. W. H. Cole, O.B.E., M.I.E.E.,** has relinquished his position as manager of the Marconi Company's Communications Division and became director of product planning. He joined the company in 1921, on leaving school. He entered the Marconi College in 1927, and was subsequently appointed to the technical staff, where he was concerned with the construction and operation of the first short-wave radio "beam" stations. In 1929, he transferred to Cable and Wireless eventually becoming personal assistant to the engineer-in-chief. By 1942, he had taken charge of a design and development group and he was ultimately responsible for the operational planning of services. In 1948,



*A. W. H. Cole*

Mr. Cole returned to Marconi's as manager of the Communications Division, which has now been split into two separate divisions handling radio and line communications respectively. The manager of the new Radio Communications Division is **A. R. Laws** and the manager of Line Communications Division is **P. R. Keller, B.Sc., A.M.I.E.E.** Mr. Laws joined the company as sales manager of the Communications Division in 1961 when he retired from the Royal Signals with the rank of Major. He is 48. After six years in the Post Office Engineering Dept. he joined the Army in 1943 and was engaged on the Commonwealth Communication Army Networks. Mr. Keller, who joined Marconi's in 1944 has been in charge of the section formed in 1956 to develop error-correcting telegraph equipment.

**Prof. J. F. Coales, O.B.E., M.A., F.Inst.P.,** is the first chairman of the Board of the recently constituted Control and Automation Division of the I.E.E. For some years he was in charge of post-graduate studies in control engineering at Cambridge University where he now occupies the chair of engineering control. After graduating at



*Prof. J. F. Coales*

Sidney Sussex College, Cambridge, he held various appointments in the Admiralty Dept. of Scientific Research and Development from 1929 until 1940 when he was put in charge of development of naval gunnery radar in the Admiralty. In 1946 he joined Elliott Brothers as research director where he stayed until joining the staff at the University in 1952.

**D. W. Heightman, M.I.E.R.E.,** joint managing director of Goodmans Industries, Ltd., has also been appointed a director of Radio Rentals (U.K.), Ltd., and of Rentaset, Ltd. (all associated companies). In 1938 Mr. Heightman formed Denco Ltd., of Clacton, of which he later became managing director. In 1950 he joined the English Electric Company as chief television engineer. Since 1956 he has been with the Radio Rentals group which he joined as chief engineer. He has been a director of Goodmans since 1962.



*D. W. Heightman*

**Alec H. Reeves, A.C.G.I.**, inventor of pulse code modulation, is to receive the Stuart Ballantine medal of the Franklin Institute in America on October 20th. Mr. Reeves, originally joined the International Western Electric Company (parent of S.T.C.) and in 1928 went to the associated laboratories in Paris.



A. H. Reeves

Throughout the last war he worked on radio-countermeasures and on guidance and accurate bombing systems for the R.A.F. Since 1946 he has been at Standard Telecommunication laboratories at Harlow, Essex. Mr. Reeves, who was born in Redhill, Surrey, in 1902, originated p.c.m. while working in Paris but it was not until the coming of transistors that it could be used economically. It was employed to transmit television pictures of Mars from Mariner IV, and is also being used experimentally in the U.K. telephone system.

**Lt. Col. J. P. A. Martindale, B.A., B.Sc., M.I.E.R.E., A.M.I.E.E.**, has been appointed full-time secretary of the National Electronics Research Council, of which Earl Mountbatten is chairman. Since the inception of the N.E.R.C. in 1961, G. D. Clifford, secretary of



Lt. Col. J. P. A. Martindale

I.E.A.E., has also been secretary of the Council and will continue to assist it by following up discussions already held in Australia, Canada, India and New Zealand on the formation of similar bodies in those countries. Col. Martindale has been in industry for the past five years. During his military service he held various technical appointments in the Ministries and was at one time a member of the staff of the Royal Military College of Science.

**R. W. Beattie** has been appointed managing director designate of Electrosil Ltd., of Sunderland, Co. Durham. He was until recently an executive director of the Telephone Manufacturing Co. and manager of their Capacitor Division. Previously he was head of the physical laboratories at Automatic Telephone and Electric Co.

The Marconi Company has appointed **D. G. Smee, M.B.E., Assoc. I.E.E.**, as commercial director. Mr. Smee has been with the Company since 1933, with the exception of the war years, and has been assistant general manager since 1963. He was formerly the manager of the Company's Broadcasting Division. He joined the Company at the age of 26, working at the Research Laboratories until the outbreak of war, when he joined the Royal Signals. He



D. G. Smee

later transferred to R.E.M.E. in which he attained the rank of major. Mr. Smee succeeds **F. Wheeler**, who has been with the Group since 1918 and is approaching retiring age.

**D. P. Leggatt, B.Sc.**, who joined the B.B.C. in 1953 and since 1962 has been engineer-in-charge of television recording, has become head of the film unit of the Planning and Installation Dept. He is succeeded as e.-in-c. television recording by **A. E. Nicholas, A.M.I.E.E.**, who has been with the Corporation since 1947. For the past four years Mr. Nicholas has been engineer-in-charge of film maintenance at the B.B.C. Television Film Studios at Ealing.

**P. Goudime, M.A.**, managing director of Electronic Instruments Ltd., which was acquired by Cambridge Instrument Company in 1960, has been appointed technical director and as such will be responsible for research and development for both companies. Mr. Goudime, who is a past-president of the Scientific Instrument Manufacturers' Association, took an honours degree in natural sciences at Cambridge University. He then worked on the design of aircraft navigational equipment and throughout the war was head of the research department of Simmonds Aerocessories. Immediately after the war he formed Electronic Instruments Ltd. He is also a director of the Minerva Detector Company which he formed in 1950.

**Edward J. Whitmore, A.R.C.S., B.Sc., D.I.C., Ph.D., M.I.E.E.**, has been appointed manager of the newly formed Light Conversion Devices Division of the English Electric Valve Company. Dr. Whitmore was engaged in research into electron diffraction and crystallography at Imperial College from 1939 until 1941 when he joined Ferranti Ltd., Manchester, and worked on microwave engineering. He was chief engineer with Ferranti Ltd., Grantown, Scotland, from 1947-55. He then joined the Canadian Marconi Company in Montreal as engineering manager. In 1960, he joined the Microwave Division of Sylvania Electronic Products Inc., U.S.A. Shortly after, he was made manager of their Williamsport operation, a position he held until his present appointment.

**A. S. Figgis** has been appointed chief development engineer of Rank Pullin Controls, part of the Rank Organization. Mr. Figgis, who is 38, joined the company more than ten years ago as a development engineer.



A. S. Figgis

**M. Leeuwijn**, author of the article describing slow-motion television techniques in this issue, joined the Philips organization in Eindhoven in 1925 at the age of 19. In 1957 he was appointed technical-commercial director of the radiogramophone and television group in Eindhoven. Since 1963 he has been in Japan.



## Three Technical Colleges Fitted With Marconi Marine Gear

EQUIPMENT which will assist training students to become marine radio officers is to be installed in specially designed classrooms—closely resembling, in appearance, a vessel's radio room—at the South Shields Marine and Technical College, the Dublin College of Technology, and at the Lowestoft College of Further Education.

At the South Shields Marine and Technical College, where there is already quite a lot of Marconi Marine equipment, an "Editor" automatic transmission system is to be fitted. This high-speed, high-frequency transmission apparatus has automatic error correcting facilities and, for the past two years, has been used by Shell International Marine to communicate ship's performance data from selected vessels to their central office. The South Shields installation will be suitable for simultaneous two-way working. A close-circuit television installation of the type used to assist vessels in docking and general manoeuvring in restricted waters is also to be fitted. A Marconi Marine "Crusader" and "Pennant" s.s.b. transmitter and receiver, an "Argonaut" v.h.f. transceiver, a "Forecaster" receiver and an 18-in weather facsimile recorder complete the South Shields installation.

A wide range of communications equipment, radio navigational aids and radar is to be installed at the Dublin College of Technology. This includes two "Oceanspan VII" transmitters and two "Atalanta" receivers, two "Lodestar" echosounders and two "Argus 12" stabilized screen radar installations.

At Lowestoft communications equipment and radio navigational aids, similar to that ordered by Dublin, are to be installed.

**Myriad, the microelectronic computer** developed originally by the Marconi Company, is to be used by the Central Electricity Generating Board in its experiments on automatic control of power generation and distribution. Together with analogue and digital input and output devices the order, placed with English Electric-Leo-Marconi Computers (E.E.L.M.), is worth £130,000 and follows a £1M order last year for four KDF7 real-time computers. The order represents the first sale of a Myriad for civil use, the computer previously being extensively used in radar defence systems. The Myriad, which has been described as a third-generation computer, can perform simple arithmetic in 2.5µs. Myriad and its associated equip-

ment will be used to study the transfer of information between a computer system and a human plant operator and also to investigate the value of predictive optimal control systems based on the use of a digital computer for continuous plant control. In addition it will be used with a supply system simulator to study plant loading techniques.

**£½M Simulator ready for the Royal Navy.**—The Solartron Electronic Group, of Farnborough, have completed a £500,000 contract for a digital simulator, which is soon to be installed in *H.M.S. Dryad*. It is to be used for training in blind pilotage navigation, day-to-day fleetwork, and manoeuvres—as well as tactical training of Command teams, etc. A high-speed special purpose digital computer with an addition time of one microsecond and a cycle time of two is employed in this simulator, the correct title of which is Surface Tactical and Blind Pilotage Trainer. The computer and associated central equipment—such as echo generators, resolvers, symbol generators, output circuitry, etc.—is housed in 20 nine-foot racks. The master and assistant control desks in S.T.B.P.T. contain normal surface radar display equipment—which can show the radar picture from any one of six radar carrying ships—a tactical display monitor, range and bearing indicators, repeater instruments, and various other controls. Each of the six radar-carrying ships provided by this simulator contains its own coast-line generators. Eighteen mobile targets which can be ships, aircraft, helicopters or submarines (all are steerable with speeds of up to 1,000 knots) are provided along with six fixed targets which can represent buoys or other sea marks.

**American Radio and TV Figures.**—According to production figures issued by the marketing services department of the Electronic Industries Association, the number of colour television receivers built in the United States in the first six months of this year totalled 1,083,093. This represents an increase of 80.7% on the comparable 1964 figure of 599,345. However, the production figures for black-and-white receivers for the same periods were quite different inasmuch as there was no significant change at 3,962,000 units in 1965—a rise of only 1.6%. Total radio production for the first six months of this year at 11.5 million units was 29.5% up on the first half of 1964. This figure includes car radios which in both years represents approximately half the total, and f.m. radios. A rise of 72.4% was noted in the production of f.m. receivers; this year's total being 1,410,418.

**The Instrument Enquiry Service** of the British Scientific Instrument Research Association (SIRA), formed seven years ago, has been integrated with SIRA's technical advisory and enquiry service to form a more comprehensive service which can provide help for problems which cannot be solved by merely proposing commercially-available apparatus. The service can now act as an information centre on technical matters through a wide range of fields such as thin-film technology, microelectronics, data processing, electron microscopy, etc. Known as SIRAIID the service is described as the SIRA automation and instrumentation information and data service. The address is SIRAIID, South Hill, Chislehurst, Kent. (Tel.: IMPerial 0055.)

**Valve and Semiconductor Exports Increase.**—During the second quarter of this year, exports of electronic valves, tubes and semiconductor devices reached a total of £3,346,925, according to figures issued by VASCA and B.V.A. This figure, which is based upon Customs and Excise returns, shows an increase of 10.3% over the first quarter of this year. Of the semiconductor devices, the biggest portion of the exports was in germanium transistors, which totalled £214,927 in the first quarter and £263,671 in the second quarter of 1965. Television picture tube exports were £451,211 in the first quarter and £677,447 in the second. The combined valve and tube exports in the first three months amounted to £2,403,761 and £2,666,706 in the second quarter.

**Sprague Electric Company**, of North Adams, Mass., have formed a wholly-owned British subsidiary. Called Sprague Electric (U.K.) Ltd., it will market all the parent's products—which include semiconductors and microcircuits—from Coldharbour Lane House, 126 Coldharbour Lane, Hayes, Middx. (Tel.: HAYes 8833.) Sprague products were previously sold through the Telegraph Condenser Company.

**Granger Associates Ltd.**, who have so far imported equipment from their American parents, are moving from Weybridge, Surrey, to new premises at Russell House, Molesey Road, Walton-on-Thames, Surrey, where they will be manufacturing equipment. Initially they will produce h.f. communications aerials, but eventually will make a range of equipment including ionosphere sounders and balun transformers.

**Marconi Television Transmitters for Portugal.**—As part of an expansion programme, Radio Televisai Portuguesa is to open two new television stations later

this year, one at Muro in the north and one at Mendro in the south. Marconi Band III transmitters will be used at both locations, a 5-kW vision and 1-kW sound in the north and a 10-kW vision and a 2-kW sound in the south. When both of these stations are commissioned R.T.P. will cover 95% of the country and reach 97.8% of the population.

**Speytec Ltd.** is the name of a new company formed by a group of engineers offering a design service to industry. Once a problem is posed, the company states, "the procedure is usually to prepare an initial brief proposal which outlines a practical *modus operandi*. This will indicate the extent of design and development work and prototype equipment involved, together with estimates of cost and timescales, etc." The design offices and laboratories are at 34 Broadway, London, S.W.1. (Tel.: SULLivan 3946.)

**Plessey-T.C.C.**—Following the acquisition of the Telegraph Condenser Company, Plessey's have decided to move their solid tantalum capacitor production lines from Towcester to T.C.C.'s premises at Bathgate, Scotland. T.C.C. ranges of solid tantalums will continue to be produced at Bathgate along with the Plessey ranges which, incidentally, will continue to be marketed at Towcester.

An ultrasonic system for locating leaks in underground pressurized communications cables has been introduced by the Delcon Division of Hewlett-Packard, Palo Alto, California. Actual locating is effected by placing a microphone (which can detect the ultrasonic energy released by dry air or nitrogen under pressures of 5 to 10 p.s.i.) next to the leak. Aluminium rods, that can be interconnected to give a working distance of up to 300 ft, are used for siting the microphone.

**Machtronics Incorporated**, manufacturers of video tape recorders of Palo Alto, California, are in future to be known as the MVR Corporation.

**Kollsman Instrument Ltd.**, of The Airport, Southampton, Hants., have received orders for height and airspeed transducers from the Plessey Company and from Royston Industries. These transducers will be used in aircraft accident data and maintenance recording systems.

**Japanese closed-circuit television equipment** made by Ikegami and imported by Hornton's Electronics Ltd., of Lombard House, Great Charles Street, Birmingham 3, now includes a low-cost video recorder.

**Wesgrove Electronics Ltd.**, who make video tape recorders and automatic television cameras, have moved from New Street, Worcester, to 1 Maddox Street, London, W.1. (Tel.: REGent 4114.)

**U.K. Solenoid Ltd.**, of Hungerford, Berks., who manufacture rotary switches and contactors, have opened a London office at 19 Old Queen Street, S.W.1. (Tel.: WHItchall 5894, Telex 263954.)

**Thorn-Parsons.**—The sales office of the Thorn-Parsons Company has moved from Wellington Crescent, New Malden, Surrey, to 146 Great Cambridge Road, Enfield, Middx. (Tel.: ENField 5353.)

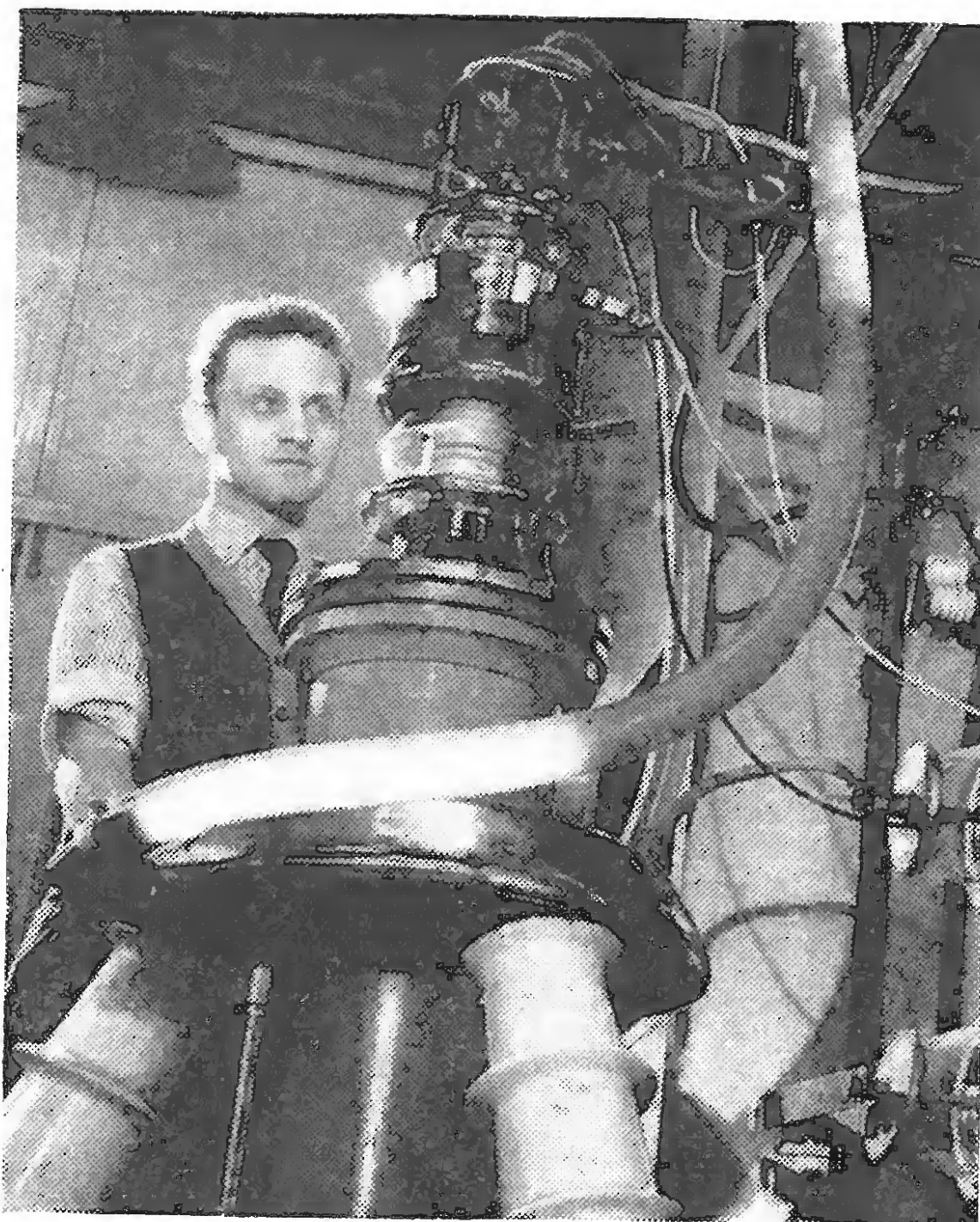

After being high-voltage tested at Standard Telephones and Cables factory at Paignton, Devon, this 150 kW triode valve is to be exported to Sweden. It will be used in a high-power broadcasting transmitter.

**Plessey.**—Administrative headquarters of the new Electronics Group of the Plessey Company have been established at Surrey House, Temple Place, Strand, London, W.C.2. (Tel.: TEMple Bar 7722.)

**G.E. Electronics (London) Ltd.**, of Eardley House, 182/4 Campden Hill Road, Kensington, London, W.8, have been appointed sole agents in the United Kingdom for the following American semiconductor device manufacturers: Crystalonics Incorporated; Solid State Products Incorporated; and Unitrode Corporation.

**SGS-Fairchild's** second United Kingdom factory is to be built on Middlefield Farm, Grangemouth Road, Falkirk, Scotland. The site covers 11½ acres and the new factory is scheduled to be in full production during 1967. A temporary factory of some 5,000 sq ft is now under construction and will be productive in the early part of October this year.

**Green and Davis Ltd.**, of 104 Hornsey Road, London, N.7, manufacturers and distributors of communications equipment, have changed their name to Green Electronic and Communication Equipment Ltd.

**Reslosound Ltd.**, of 24 Upper Brook Street, London, W.1, announce that all future sales enquiries, orders and general correspondence will be dealt with from their factory at Spring Gardens, London Road, Romford, Essex. (Tel.: ROMford 49087.)

**General Dynamics Corporation**, of New York, have opened a European information office in Paris. The address is 215 Boulevard Saint-Germain, Paris 7e.

**The Hysol Corporation**, of New York, have opened offices in Corney Road, Chiswick, London, W.4, and will operate under the name Hysol International. Their complete range of materials for impregnating and encapsulating components is offered.

**Burndept Electronics Ltd.**, of Erith, Kent, are to supply the Royal Australian Air Force with 500 of their search and rescue beacon equipment Sarbe. These beacons, which are worn in the pocket of an airman's lifejacket or packed in survival kits attached to ejection seats, operate on the international distress frequency of 243 Mc/s and have an operational range of approximately 200 miles—to an aircraft flying at 30,000 ft.

**W. Mackie & Co. Ltd.**, who manufacture power supply equipment, have moved from Lambeth Road, London, S.E.1, to a new factory in Willow Lane, Mitcham, Surrey. (Tel.: MITcham 0951.)

**The Bissesst-Berman Corporation**, of California, and the Plessey Company, of Ilford, Essex, have signed a reciprocal marketing and manufacturing licensing agreement covering oceanographic and meteorological apparatus.

**Standard Telephones and Cables Consumer Products Division** have received orders for nearly £300,000 worth of television chassis from Norway and Sweden since last autumn.

**Honeywell Controls Ltd.**, of Brentford, Middx., have received a contract, valued at £50,000, for the main instrumentation for a new ammonia synthesis plant in East Germany.

**Wayne Kerr** have received orders worth more than £40,000 from the Chinese Peoples Republic for electronic instruments, consisting mainly of precision a.c. bridges, electrometers and servo performance analysers. For several years now, Wayne Kerr have exported nearly 50% of their products. About half of their exports go to the U.S.

Decca electronic equipment has been chosen for the Royal Air Force's C.130 transport aircraft. The ordered equipment includes Decca Navigators, Decca Dopplers, Decca lat/long computers and Decca Roller Maps.

# LETTERS TO THE EDITOR

*The Editor does not necessarily endorse opinions expressed by his correspondents*

## Systems Engineers

I CONSIDER I should be failing in my duty as a professional engineer were I to let pass, without comment, your Editorial on systems engineers in the September issue. As in any business, profession or vocation there are always good, bad and indifferent members practising their skills and arts with varying degrees of success. To class systems engineers *in toto* as "virtually amateurs" is, in my experience, almost without parallel in the annals of technical journalism.

Has it ever occurred to you, Sir, that there are, broadly speaking, two classes of engineers. The first is the competent engineer who, when presented with a definite problem, can doubtless derive a correct solution. There is also the engineer who has the wit to see that a problem exists to be defined, sets about defining it and finally derives an acceptable solution. I would suggest that it is this latter citizen who contributes the really material advances to our science/art and I would further suggest that it is mainly this type of engineer who is of any value as a systems engineer. It is my opinion that the greatest single failing of professional electronics/radio engineers is that they persist in thinking that their little bits of fancy circuitry are the ends in themselves whereas in fact they can, almost by definition, be *only* the means to the end.

The systems engineer is concerned primarily with the end result and since the whole is only as good as its component parts he must have a surprisingly wide and detailed knowledge, not only of what can or cannot be done today but what is likely to be done or not done tomorrow. The systems engineer unlike most development and research workers is responsible to his management for not only the technical excellence of his system but also for the justification of capital investment involved and all that that implies, to say nothing of contractual decisions between customer and contractor which, like the poor, are always with us.

In conclusion permit me to add that I do not regret the 18 years or so I spent on research and development with its comparatively narrow field of vision since it enables me as a communications and control systems engineer to understand the equipment designers problems and at the same time dispense the odd pinch of salt as and where it is required.

Bishop's Stortford.

W. T. BROWN

## Warning

I THINK your readers ought to be made aware of the fact that there are devices on the market called a.c. adaptors, made in Japan, which are potential hazards to life. When used as a substitute for a 9V battery it would be possible for a transistor radio's exposed metal parts such as knobs or speaker grille to be connected direct to the live side of the mains.

The adaptor contains a bridge rectifier in series with a 0.2 $\mu$ F capacitor placed directly across the mains supply. The d.c. output is taken from the bridge rectifier with a 50 $\mu$ F smoothing capacitor across the output connections. This means that one side of the output connection is

joined to one side of the mains through a low voltage rectifier. There is no coding on the mains lead, which is 2-core and could be connected so that the live side of the mains appears on the output circuit.

These devices are on sale in shops at about £1 each and have been advertised in your columns.

D. A. LEVELL,  
High Barnet, Herts.      Levell Electronics Ltd.

## Semiconductors

IN the ordinary meaning of words this is surely a misnomer, among many in electronics. For even if at one end conduction were uniform and at the other insulation were infinite, by no stretch of the imagination, does a piece of slightly impure germanium lie at the half-way point.

Why not mini-conductors? I give notice that in my small corner I shall, in future, call them mini-conductors. Who knows, one day they may be so known in the States, thus reversing a long term trend.

London, N.10.      C. A. HARRIS

## OCTOBER CONFERENCES AND EXHIBITIONS

*Further details are obtainable from the addresses in parentheses*

### LONDON

- 4-13      Olympia  
Business Efficiency Exhibition
- 5-6      St. Ermin's Hotel  
Ultrasonics for Industry—Conference & Exhibition  
(Ultrasonics, Dorset House, Stamford St., S.E.1.)
- 27-30.      Seymour Hall  
R.S.G.B. Radio Communications Show  
(P. A. Thorogood, 35 Gibbs Green, Edgware, Middx.)

### OVERSEAS

- 4-6      Toronto  
Canadian Electronics Conference  
(I.E.E.E., 1819 Yonge St., Toronto 7, Ontario)
- 7-12      Genoa  
Communication Congress  
(I.C.C. Secretariat, c/o Civico Instituto Colombiana, Palazzo Tursi, Genoa)
- 9-17      Mexico City  
Congress of Electrical, Electronics & Mechanical Engineering  
(Ing. J. Espinoza, Colegio de Ingenieros, Culiacan No. 115, Mexico City)
- 11-15      New York  
Audio Convention & Exhibition  
(Audio Engineering Society, Box 383, Madison Sq. Stn., New York, N.Y.10010)
- 13-19      Düsseldorf  
Interkama—Measuring Instruments & Automation  
(NOWEA, 4 Düsseldorf 10, Postfach 10203)
- 14-23      Milan  
Excot—Exhibition & Congress of Telecommunications  
(Comité International de Télévision, Casella Postale 33, Novara, Italy)
- 20-22      Washington  
Electron Devices  
(I.E.E.E., 345 E.47th St., New York, N.Y.10017)
- 25-27      Chicago  
National Electronics Conference  
(N.E.C., 228 La Salle St., Chicago, Ill.)
- 27-29      Baltimore  
Aerospace & Navigational Electronics  
(B. W. Moss, Martin Co., Box 988, Baltimore, Md.)

## DYNAMIC ANALYSIS OF ACOUSTIC NOISE

IN a number of situations normal methods of noise measurement using frequency and spatial analysis techniques are inadequate for the location of some noise sources. One such situation would be the location of noise sources in automatic machinery. A method which permits the instantaneous recording of dynamic noise levels in a document handling machine is described by R. H. Peterson and R. L. Hoffman in a short communication published in the *I.B.M. Journal* of May 1965. The system uses an oscilloscope to display the instantaneous output of a microphone, which is recorded on film. A computer is used to calculate the r.m.s. sound pressure level during any desired time interval and a detailed plot of dynamic noise level *versus* time or document position can be obtained.

A microphone is suitably positioned to equalize air-path time delays and attenuations for sources of noise at the parts of the document path to be considered. The output is displayed on one beam of a double-beam oscilloscope which is triggered when a document leading-edge passes a photocell, so that the noise output of a complete cycle of document handling (e.g. stacking) is displayed on one trace. The second beam is delayed and displays the microphone output for an increment of the cycle, and by suitable choice of delays a series of end-to-end pictures of instantaneous noise level are presented. Photographs are also taken of the document at the start of each increment—a flash is initiated from a stroboscopic light source triggered by the delayed timebase in order to correlate document position with the oscilloscope pictures.

Results of various experiments using the apparatus for analysis of document stacking indicate that (a) discontinuous direction changes in the document path should be minimized and their rate reduced by spreading in time (b) the rate of energy transfer to and from the document should be minimized by control of acceleration and deceleration, and (c) effective guides should be used to achieve maximum control of document surfaces.

## “REVERSE FUEL CELL” GENERATES OXYGEN

AN experimental device which recovers oxygen from the waste products exhaled in breathing—water vapour and carbon dioxide—has been developed by Westinghouse Research Laboratories in the U.S.A. An important possible application would be to manufacture oxygen for astronauts and other living organisms on long space missions for which large quantities of stored oxygen could not be conveniently carried. The device is basically a fuel cell working in reverse. Electric power and combustion products (water vapour and CO<sub>2</sub>) are fed into it, and oxygen is generated (instead of being consumed as in the normal fuel cell).

Individual cells are constructed as small hollow cylinders of ceramic material fitted together to form pipes. CO<sub>2</sub> and H<sub>2</sub>O flow through these pipes, and the inside and outside surfaces are metal plated to form the cathode and anode, respectively, to which the electric power is supplied. The oxygen is collected from the outside surface—the anode. Several such pipes are combined to form a battery.

The ceramic material of the pipes, composed principally of zirconium oxide, is, in fact, a solid electrolyte. It is heated to a temperature of about 1,000°C and in this red-hot con-

dition the material acts as a sieve through which oxygen ions migrate easily but no other gases present can penetrate. At 1,000°C the CO<sub>2</sub> and H<sub>2</sub>O flowing through the pipes decompose, releasing oxygen ions at the cathode. These ions move through the solid electrolyte to the anode, where they lose their excess electrons and become neutral atoms of oxygen, suitable for breathing. By-products of the process are hydrogen gas and solid carbon.

Westinghouse say that a complete oxygen generating system capable of supplying the needs of four men would weigh 60 to 75 lb, occupy a space of about 3 cu. ft. and consume about 900 to 1100 watts of electric power.

## TUNABLE OPTICAL PARAMETRIC OSCILLATOR

A COHERENT light source tunable over a relatively wide frequency range has been developed at Bell Telephone Labs. The source is a parametric oscillator using a non-linear lithium metaniobate crystal, about 0.5 cm square, and grown by Bell workers. By varying the temperature of the crystal, the output wavelength has been varied between nearly 9,700 Å and 11,500 Å.

The pump source is the second harmonic of a pulsed calcium tungstate/neodymium-doped laser (5,290 Å). A resonant cavity is formed with dielectric films at the crystal ends. The gain of the light beam at the desired frequency and idler frequency (the difference between the pump and the desired frequency) exceeds the cavity losses and light at these frequencies is generated from noise present in the cavity.

The frequencies of the idler and desired signals are determined by the refractive index of the crystal, which is dependent on the temperature. The output beams are highly collimated and have a peak pulse power of 15 W, resulting from an input pulse power of 6.7 kW. A 12° C change in temperature gave a change in wavelength of 700 Å.

More detailed information is contained in *Physical Review Letters* of June 14th, 1965.

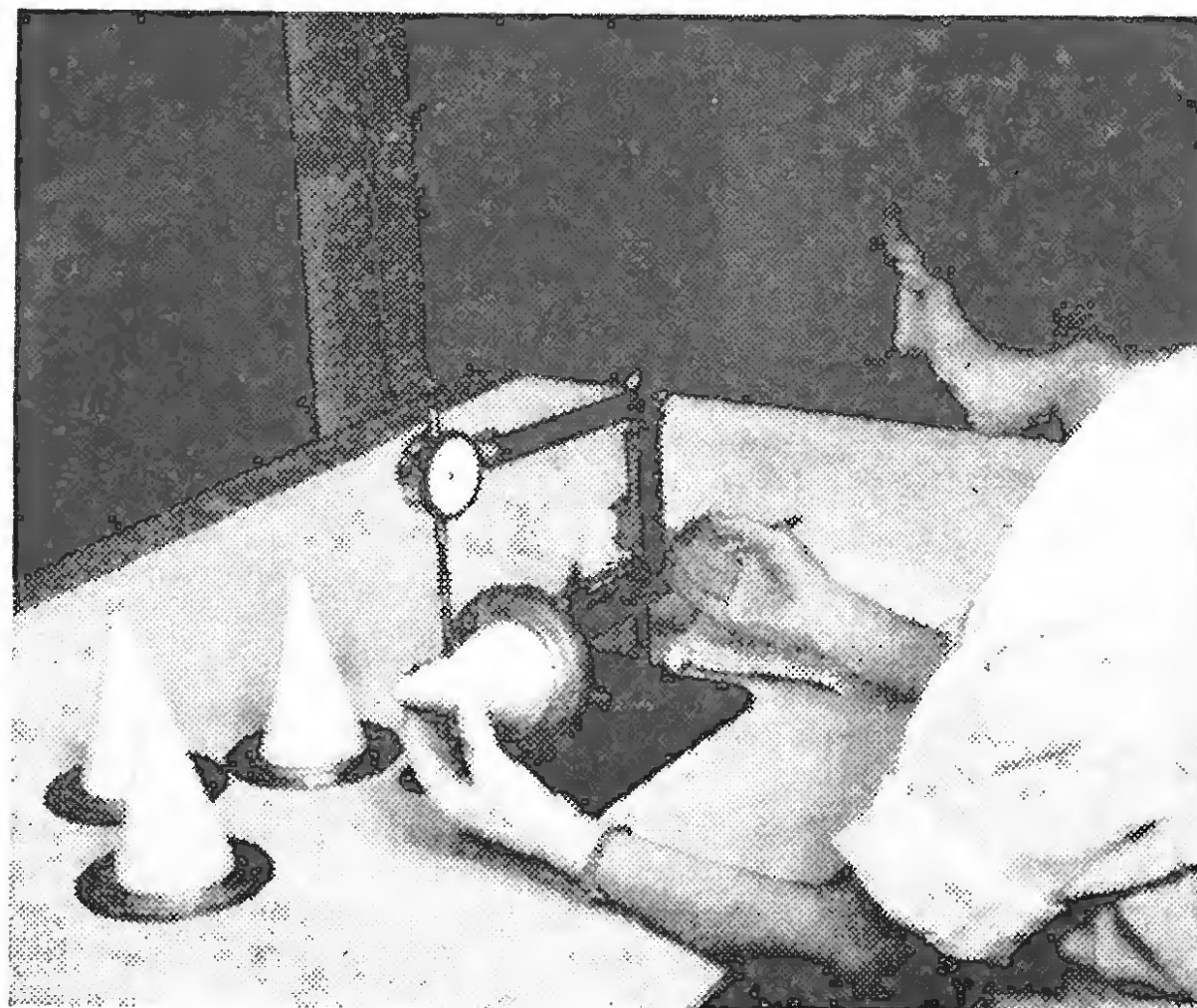

Testing uniformity of wall thickness of wideband high power waveguide windows (E.M.I.). The cone-shaped windows are made from a ceramic (alumina) and in order to ensure reliable metal-ceramic seals, the thermal expansion of the metal and ceramic must be closely matched to avoid residual strains.

# GERMAN RADIO EXHIBITION

## HIGHLIGHTS FROM THE STUTTGART RADIO & TELEVISION SHOW

**A**LTHOUGH the Hanover Fair in April is traditionally the occasion for the announcement of German manufacturers' new season's models, the biennial *Grosse Deutsche Ausstellung* gives a wider public the opportunity of seeing and hearing the new sets at first hand. This year the omission of the adjective *Grosse* from the title does not imply any diminution in size; merely the acceptance of the obvious. In every way the Show at the Killesberg Park, above Stuttgart, equalled in size and quality the standard established by its predecessors in Berlin, Frankfurt and Düsseldorf. The choice of this year's venue was influenced by the feeling that sales in the south of Germany had not shown the buoyancy of those in the northern provinces.

### Sound broadcasting

The Bavarian broadcasting organization happens also to be the only one which is not yet transmitting stereo f.m. programmes. Some say this is because of traditional

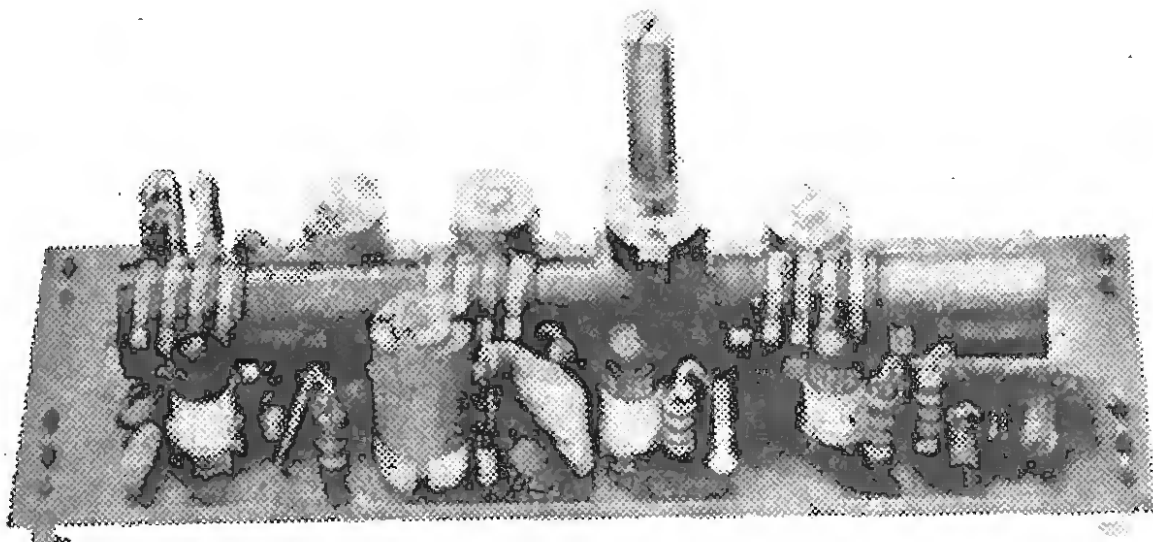

Silicon planar transistors in a three-gang inductively tuned circuit are used in the v.h.f. input circuits of the Graetz "Silvretta" stereo receiver.

Grundig service stereo coder, Type SCI.

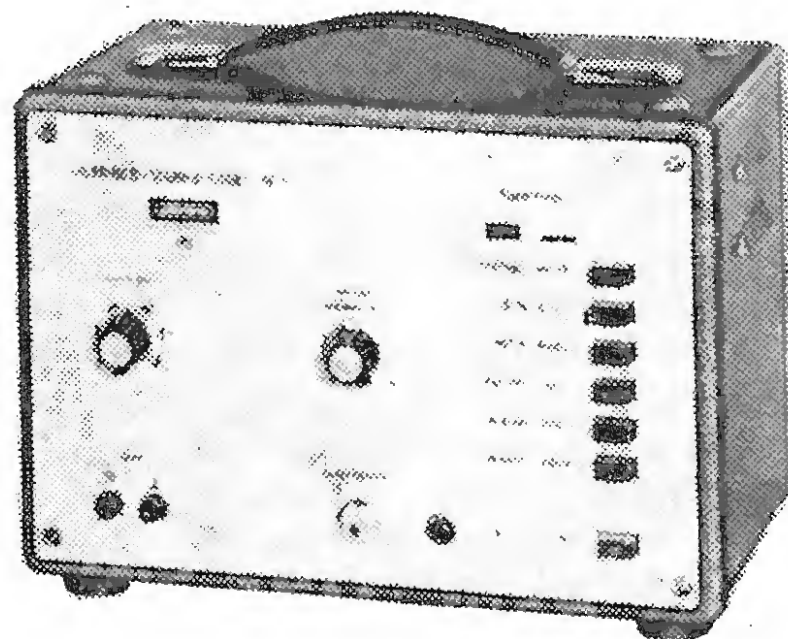

Large-screen (Eidophor) television was used to enable Dr. Erhard, the Federal Chancellor, to be seen opening the German Radio Show.

Bavarian independence, but more probably the reason is that the mountainous terrain means that more relay links have to be converted. But a service is promised by next spring and the whole of Germany will by then be enjoying an average of 10 to 15 hours per week of stereo from each of the *Land* networks. At present the average is some six hours of stereo a week, although some stations are giving 15 hours per week. *Süddeutsche Rundfunk* has already developed a stereo outside broadcast van which was shown to the public for the first time at Killesberg.

At the last German Show in 1963 in Berlin the idea of stereo broadcasting was being pushed hard by German receiver manufacturers with the collaboration of one station—*Sender Freies Berlin*. The other broadcasters, who at that time were sitting on the fence, have now all capitulated (if that is the right word) and stereo broadcasting is now established as essential not only for the enjoyment of good music but also (and perhaps more important from the point of view of sales) as a status symbol.

Every German set manufacturer now markets a fully developed range of stereo receivers, either with built-in speakers or separate small high-quality loudspeaker units of the type pioneered in the U.K. The Graetz "Silvretta" is typical of the former group and is also notable for the use of silicon planar transistors in the v.h.f. tuner which uses three-gang inductive tuning.

Stereo signal generators for servicemen are beginning to make their appearance and a good example is the Grundig SCI with push-button selection of function.

The cult of "hi-fi," which for some unaccountable reason was slow in gaining ground in Germany, is now well established and the "technische Look," as Telefunken have described it, is characteristic of many firms' new programmes. In this they are following the trend set many years ago and still foremost by Braun who this

year have an even wider range of sound reproducing equipment of the highest quality. The international journalists at the Braun preview were for once in truth "amazed" when told that the price of the Braun "Studio 1000" *Musikanlage*—an assemblage of the cream of the firm's radio, gramophone, tape and sound amplifying and reproducing units was to be had for a consideration of £1,500 (one thousand five hundred pounds). The Braun stand was also visually attractive, for their backroom boys had devised a colour projection system controlled directly by sound waves. A flat transparent diaphragm covered by a thin oil film is viewed by a Schlieren optical system which diffracts the light through a series of colour filters, depending on the thickness and/or deflection of the oil film. The Chladni figures which chase each other across the surface during the playing of music are pretty to watch. (Penny plain and twopence coloured?)

An important amalgamation in the hi-fi field is that of SABA and Klein & Hummel. In future the products of these firms are to be marketed under the title "SABA-Telewatt."

Stereo is not for everyone's pocket, nor is it absolutely necessary for car radio, which reminds us that Grundig have at last entered the car radio market with two models.

Nor have small pocket portables been allowed to stagnate. Philips have made a notable contribution with their "Mariette" (v.h.f./f.m. only, with mechanical selection of any three settings in addition to continuous tuning) and particularly its neat radiogram counterpart, the "Musette de Luxe."

## Television

Further use of transistors (for cooler chassis and longer life), and some slightly larger (65cm) tubes are the only general trends, though one or two detailed tuner designs are interesting. Integrated u.h.f./v.h.f. tuners seem now to be the order of the day.

Blaupunkt, Nordmende and Loewe-Opta all have transistor video stages and in the Blaupunkt chassis the video output stage is mounted on the picture tube socket.

The Graetz "Landgraf" G921 and the Telefunken FE2065T are examples of the use of 65-cm (25½-in) tubes.

In the Grundig "Monomat" single-knob tuner, capacitance diodes with voltage control are used for the v.h.f. bands. The bias voltage is derived from a specially shaped potentiometer element, the position of the pick-up contact being determined by a somewhat complex mechanical selector.

The aerial manufacturers again staged a "street of antennas" in the exhibition grounds. Siemens made a special point of their latest distribution system for large communal installations and particular interest was also shown in the logarithmic aerial Dezi-Durant 54 shown by Kathrein. This covers 470-790 Mc/s with a gain of 12 dB and a front-to-back ratio of 26 dB.

Loewe-Opta were showing a portable aerial-measuring instrument (Type 60 305) working from batteries and giving a picture check as well as a reading of field strength.

## Magnetic tape

Chief talking point in this sector was undoubtedly the spate of miniature cassette tape players and the growing library of recordings in this medium. The start of this trend was the introduction by Philips at the 1963 Berlin Show of the Type 330 pocket recorder with double cassette and non-standard narrow tape. This was fol-

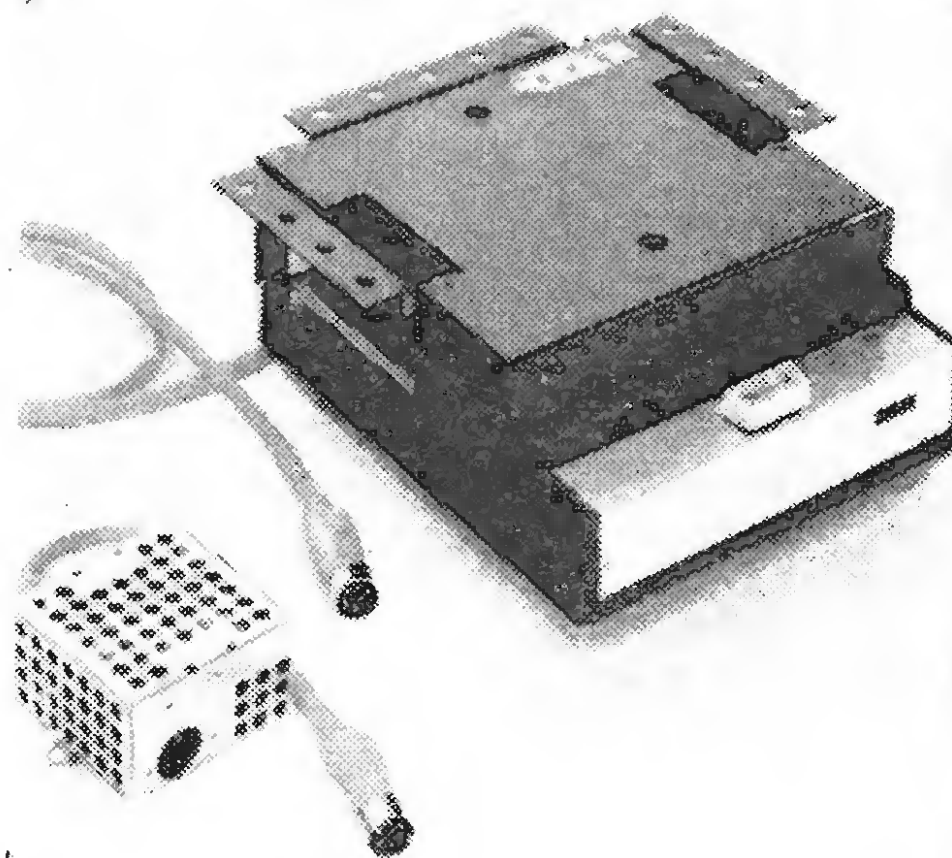

Philips Type 3305 "Compact-Cassette" tape player for car use.

lowed in 1964 by the "Sabamobil" tape player for cars and an agreement with the Ariola recording organization to supply tapes from their repertoire. Now Philips have developed a separate player (only) Type 3305, and can supply music titles from the Philips, Deutsche Grammophon or Metronome groups and their associated labels. Although this system "Compact-Cassetten" or "C.C." has been in existence barely five months, already more than 100,000 tapes have been sold. Clearly this is going to constitute a challenge to disc, though as will be seen later the newcomers have a somewhat serious handicap.

Other firms including Graetz, Loewe-Opta and Schaub Lorenz have entered into agreement with Philips for the supply of tapes though they will probably be developing their own players.

Finally, Grundig have jumped in with the C100 player/recorder and a player only (AC50) for use with their car radio. Both these use cassettes according to a third standard known as "System D.C. (Double Cassette)-International." This is sponsored by a consortium of Blaupunkt, Grundig and Telefunken and for recordings will draw on the repertoire of Telefunken, Decca and RCA Victor.

The Grundig player is notable for the use of a "brushless" d.c. motor. This is similar to the one used in their TK6L battery model and consists of an outer rotating cylindrical permanent magnet surrounding an internal stator of form similar to a conventional d.c. armature. Current to the three 120° windings is switched in succession by transistors. These are opened in turn by the influence of a ferrite segment on the rotor which passes h.f. current by induction from a 100 kc/s oscillator to stationary 120° coils each connected to successive switching transistor bases. Overspeed control is also contactless in the C100 and uses the back e.m.f. during currentless periods in the stator coils to change the impedance of a bridge circuit which is shunted across a damping circuit in the h.f. commutating section. Thus the only mechanical switch remaining in the earlier design has now been eliminated.

It seems a pity that with so much technical ingenuity in all these systems that agreement on a common standard could not be reached, so that tapes from all sources could be played on any make of machine—like disc records.

No restriction on sources of material is imposed in the "Music Center" shown by Schaub Lorenz for the first time, except those of the laws of copyright. This

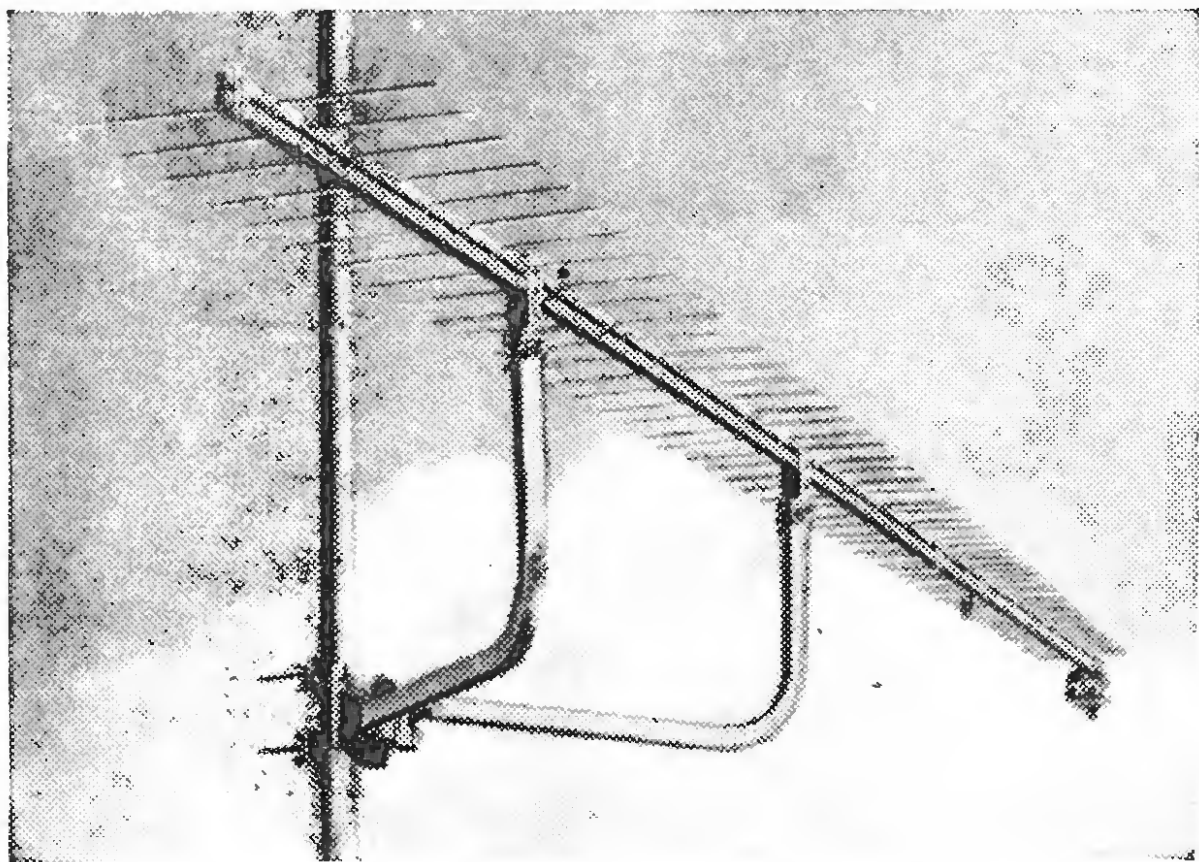

Kathrein Dezi-Durant 54 logarithmic aerial.



Saba-Telewatt hi-fi stereo amplifier VS-60.

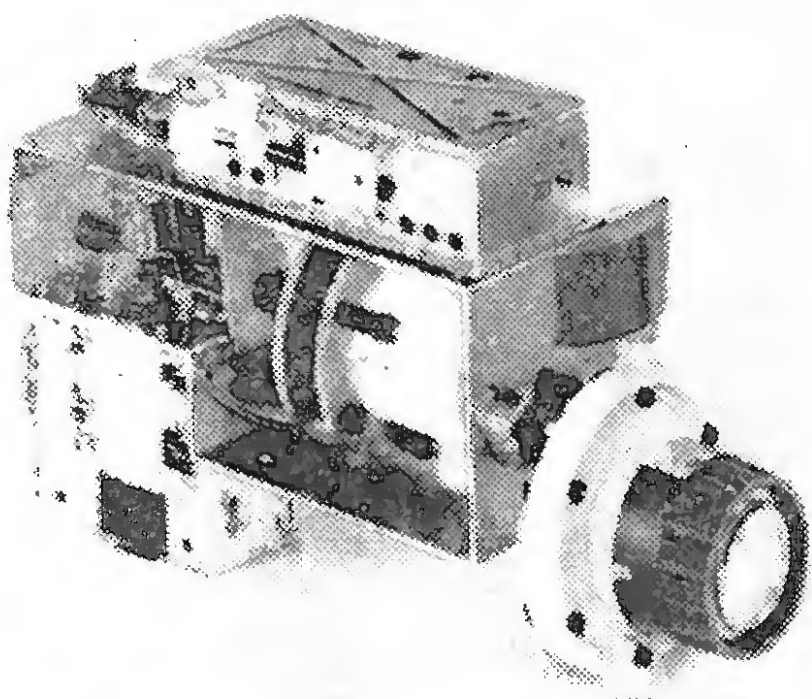

Left.—General view of Grundig "Monomat" integrated tuner.

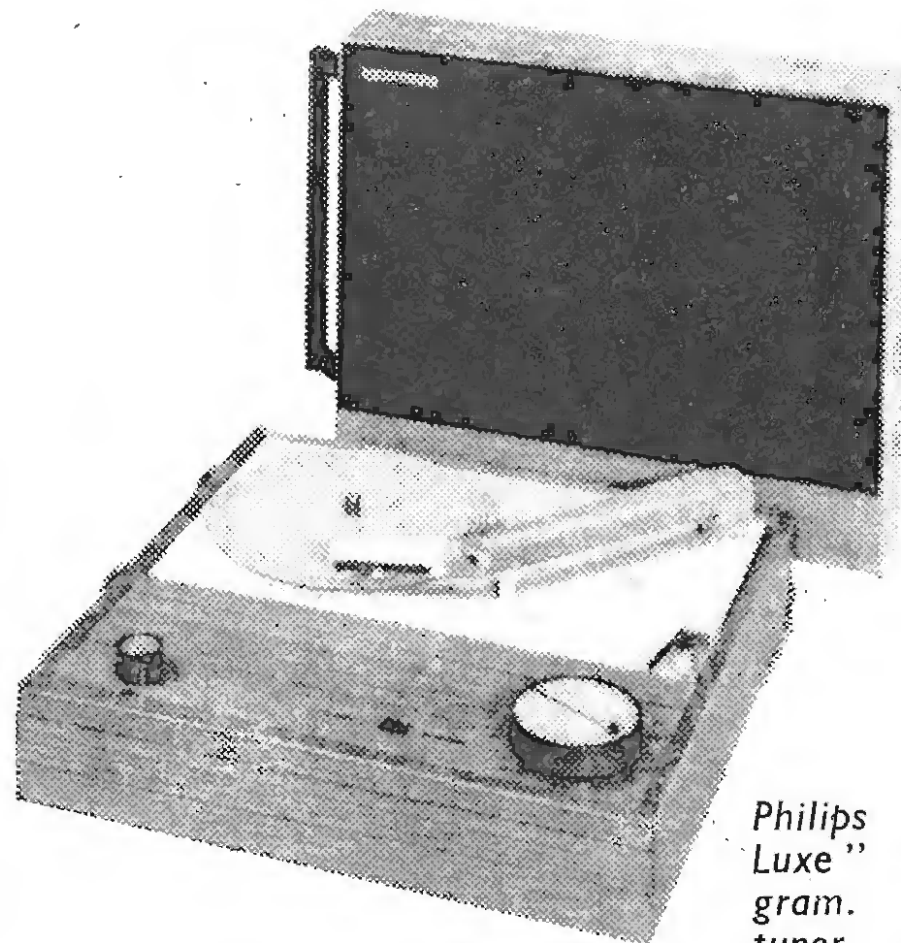

Philips "Musette de Luxe" portable radio-gram. The v.h.f./f.m. tuner provides three pre-set stations as well as continuous tuning.

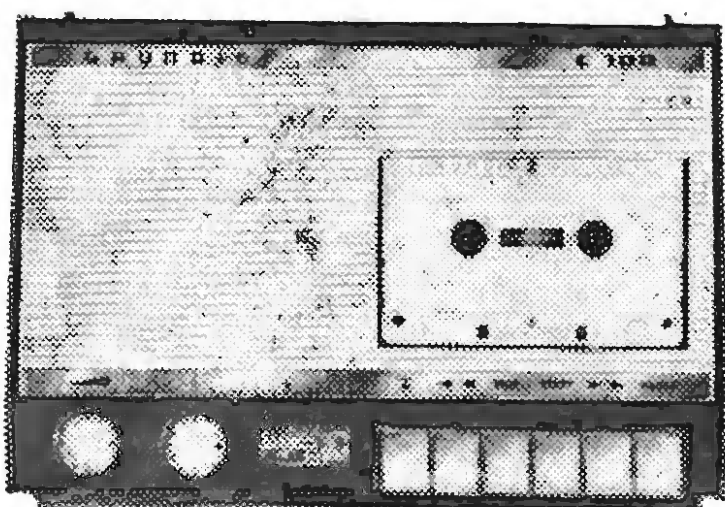

Grundig C100 cassette tape recorder.

Right.—Transistor video output stage mounted on the c.r.t. socket (Blaupunkt).

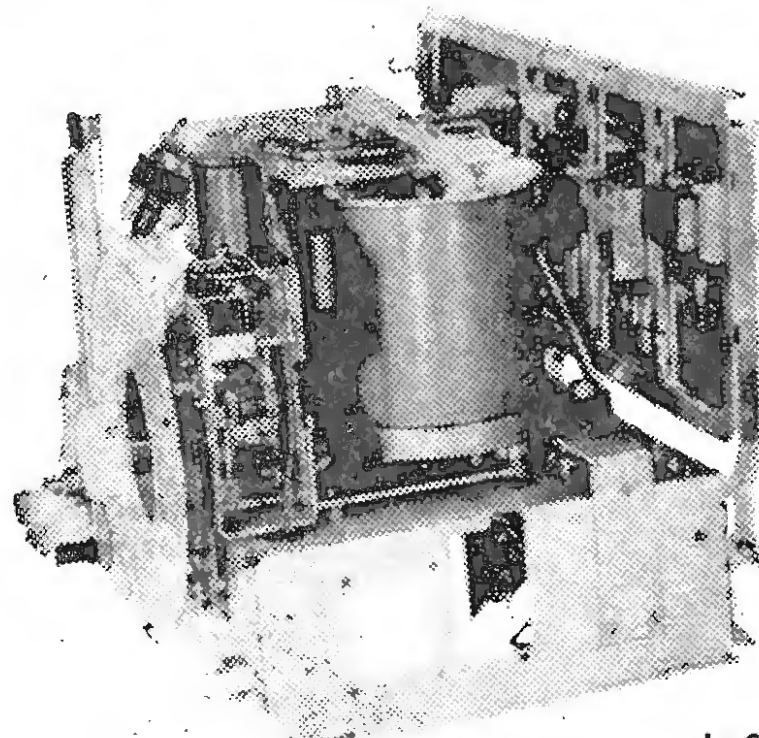
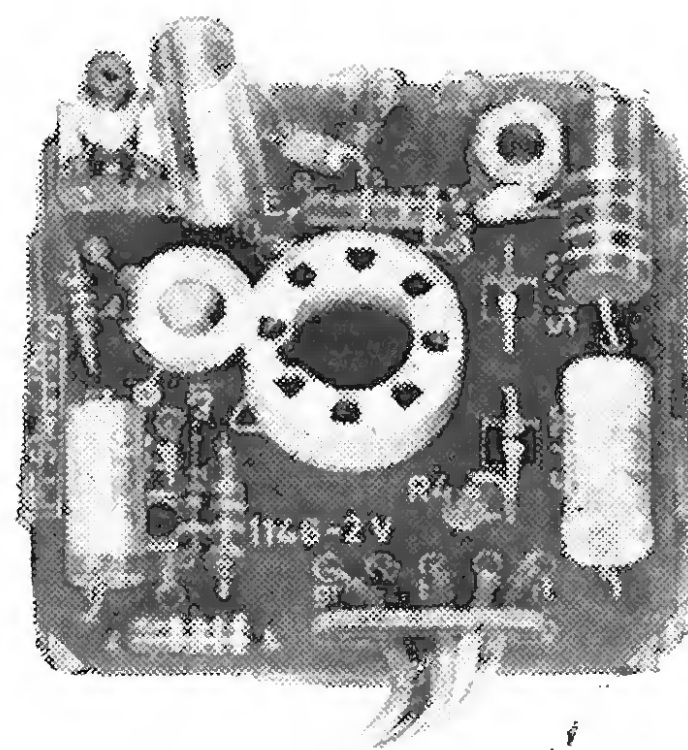

Left.—A 10 cm wide magnetic band carries 126 tracks, each of 22 mins duration, in the Schaub Lorenz "Music Center".

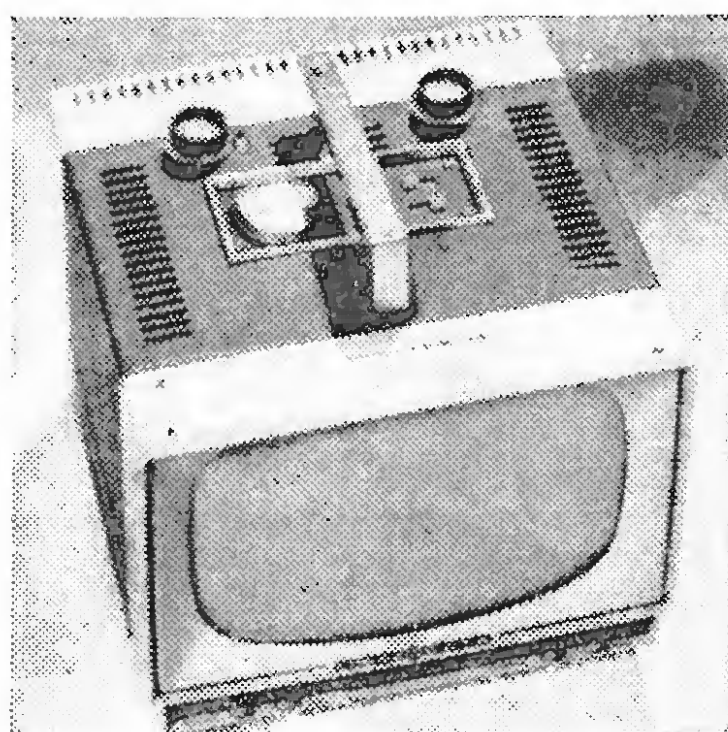

Loewe-Opta aerial measuring instrument (Type 60 305).

Below.—"Brushless" d.c. motor and switching transistor panel as used in the Grundig cassette tape recorder

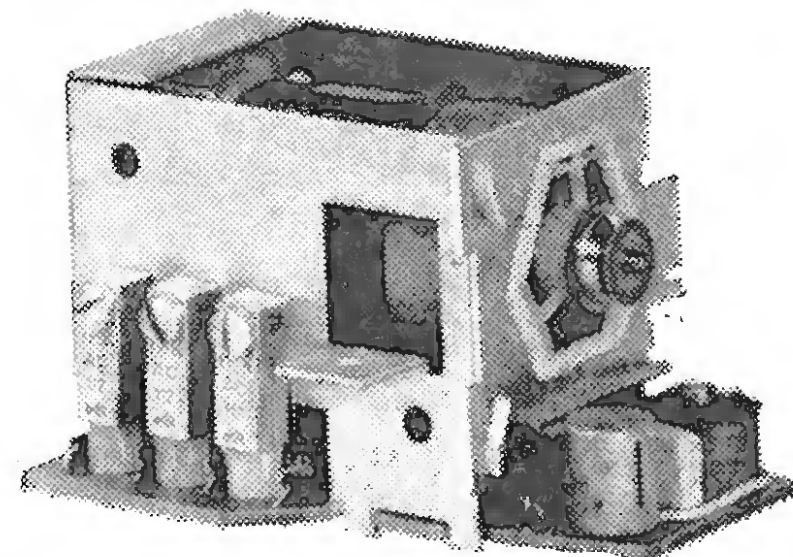

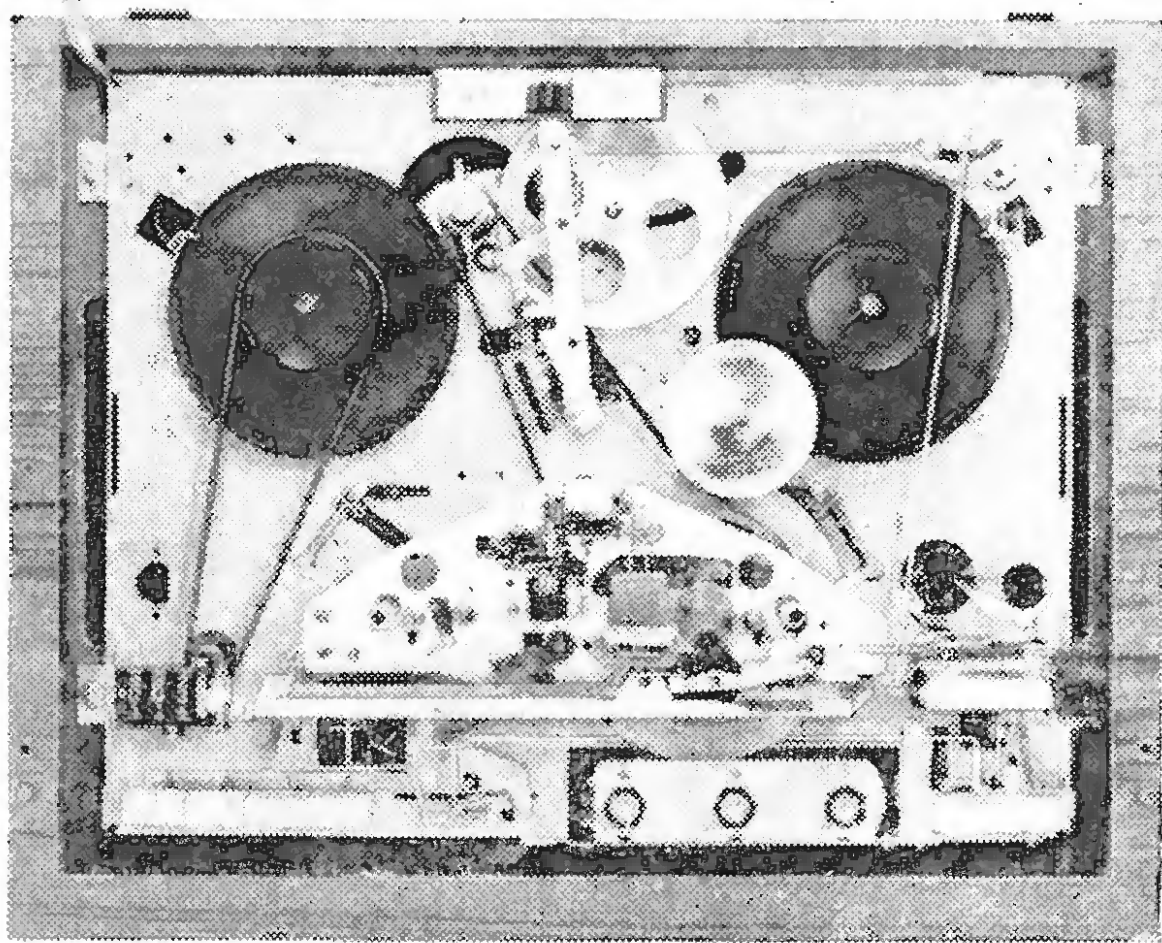

Band brakes are used in the SL100 Schaub Lorenz tape recorder.

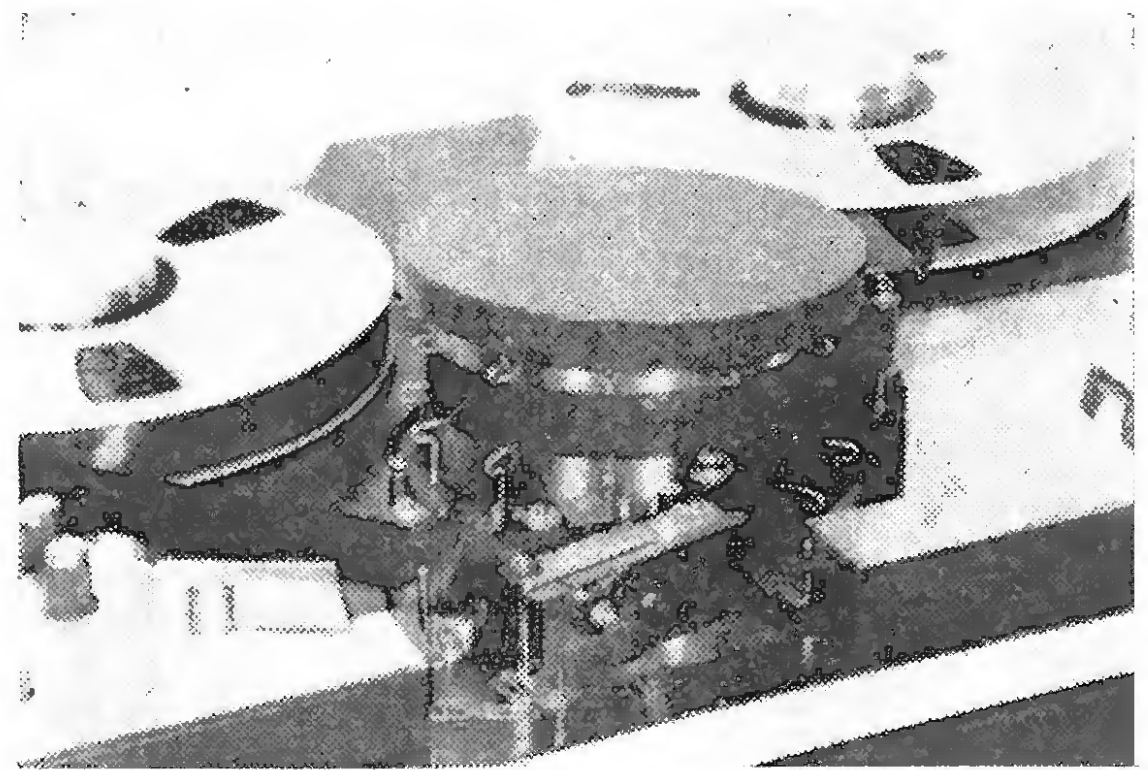

The "alpha" form of tape transport has been adopted in the Grundig video tape recorder

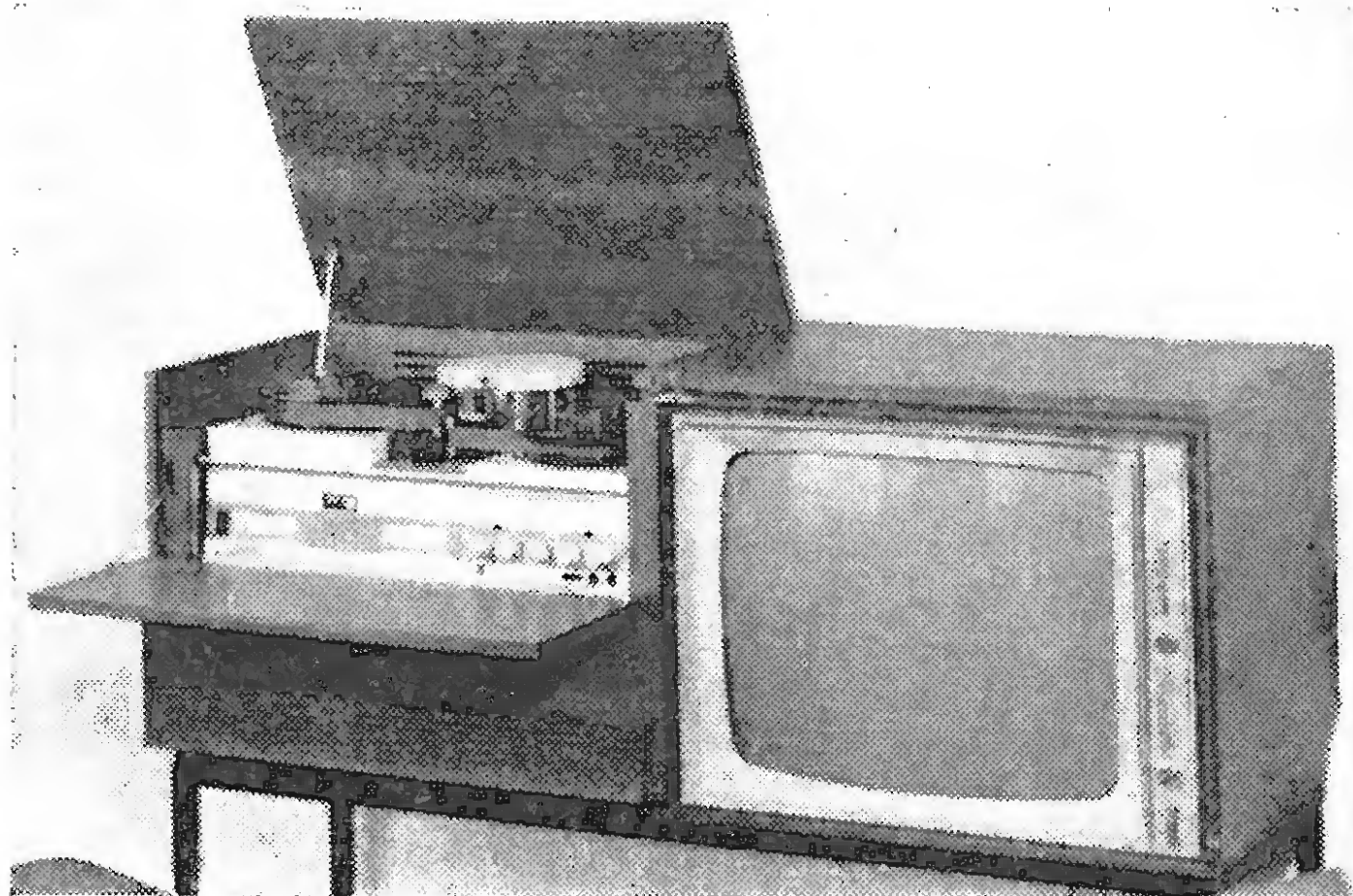

Philips video recorder console.

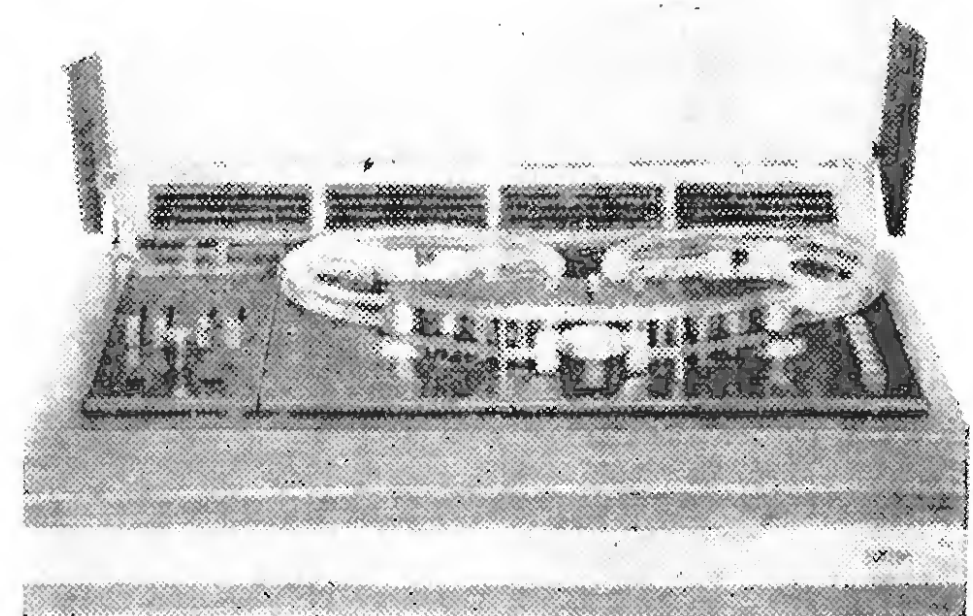

SABA studio tape recorder, 600 SH.

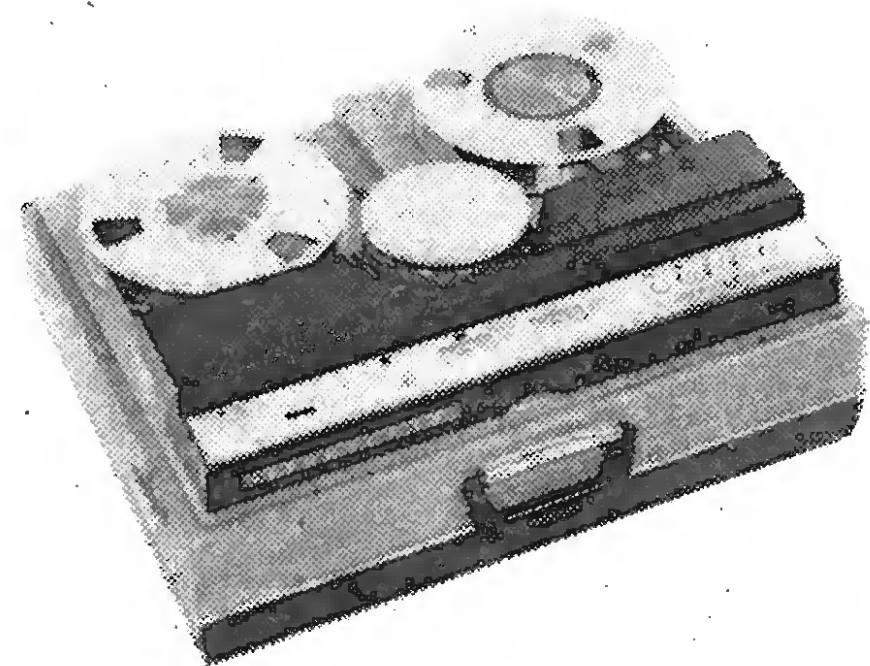

Optacord 600 television recorder.

equipment, available in table or console form, consists of a high-grade "all-wave" receiver and a special magnetic tape recorder with a programme duration of nearly 2 days and 2 nights! A 10-cm wide coated band carries 126 parallel tracks, each with a duration of 22 minutes at a speed of 12 cm/sec. Rewind time is only 25 sec and selection of a new track by the single record/playback head is effected by a dial-operated mechanical linkage. Running time for each track is shown by a thermometer type indicator.

Of more conventional design is the Schaub Lorenz portable recorder which is nevertheless of interest because it employs band brakes on the supply and take-up spools. SABA too have introduced a new hi-fi studio tape recorder with three drive motors and other refinements to fit it for inclusion in the new SABA-Telewatt programme (q.v.).

Three television tape recording machines for domestic use were shown. The Loewe Opta "Optacord" has been demonstrated at previous shows and is now much reduced in size and refined in performance. Definition is excellent (3 Mc/s bandwidth) and demonstrations given throughout the show on the open public stand

indicate that this machine may soon become available. The linear tape speed is only 15 cm/sec, but a contra-rotating scanning head inclined to the horizontal axis of the tape and traversing the circumference of an approximately 5-in diameter loop in the tape gives an effective scanning rate of 20 metres/sec, and one whole picture frame in each diagonally recorded line on the tape. Thus if the tape is stopped on playback the rotating head continues to give a still picture.

Similar machines in development were shown by Philips (now in a console complete with television receiver), and by Grundig. When these machines are available the retail prices will range from £700 to £850.

It is regretted that space does not permit us to do



justice to the many *Sonderschauen* (special shows) which included a fine historical survey by the German Post Office, culminating in some excellent working models of their "Goonhilly" at Raising, near Munich; and, as usual, a first-rate demonstration of amateur long-distance working by the D.A.R.C. And, of course, the all-

important publicity and information centres of the equivalents of B.B.C. and I.T.A., the A.R.D. and Z.D.F. We regret this the more because Dr. Erhard, the Federal Chancellor, not only honoured the industry by opening the Exhibition in person, but he made it his business to visit every hall—a tiring but rewarding experience.

## RADIO AND TV IN EAST GERMANY

### SOME IMPRESSIONS FROM THE LEIPZIG FAIR

**P**RODUCTION of radio and television sets in East Germany (Deutsche Demokratische Republik) is centred on a handful of firms (including several in East Berlin), and is co-ordinated by Radio Fernsehen Technik, a State organization. R.F.T. has much greater authority and power than for instance the British Radio Industry Council. For example the Stassfurt factory has just been ordered to take over the whole of the D.D.R. production of television sets.

Its headquarters are in Radeberg and the publicity department is in the Städtisches Kaufhaus, Leipzig, behind which still lie the ruins of the old Gewandhaus with its many historical associations with German music of the past. This building, like many others in the older part of Leipzig, is taken over during the Fair period and converted as an exhibition hall. Two floors with an area of 1,300 m<sup>2</sup> were occupied by 23 radio firms.

Official statistics put the present annual production of the radio industry in D.D.R. at £M130 with an annual

growth rate of 10 to 15%. Export is vital to the D.D.R. (as to everyone else) and special efforts are made to earn foreign currency. Chassis are well sectionalized with interchangeable units to suit the standards (transmission characteristics and climate) of any country. Thus orders from anywhere can be quickly executed. About 70% of gramophones and 60% of radio production goes for export, either to non-socialist countries or neighbouring Russian satellite states.

Technically the designs follow established and well tried principles without any straining after innovation or novelty for its own sake. About half the TV sets produced have either 53 or 59cm screens. We noted that sound quality was particularly good.

A few West German firms' agents were represented at the Leipzig Fair and also Hitachi of Japan, but the most interesting foreign stand was that of C.F.T. (France) which drew the largest crowds for the first view of SECAM which has now been, or will be, adopted in the

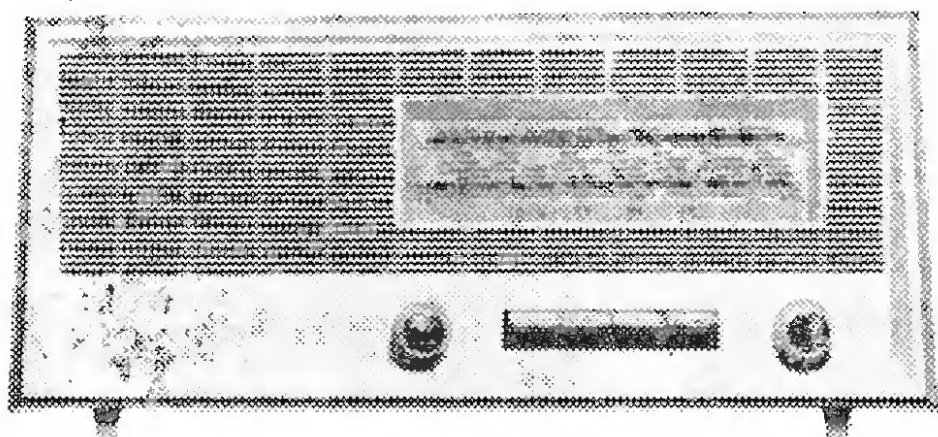

Long-, medium- and short-wave reception is provided by this table receiver: Carino 530.

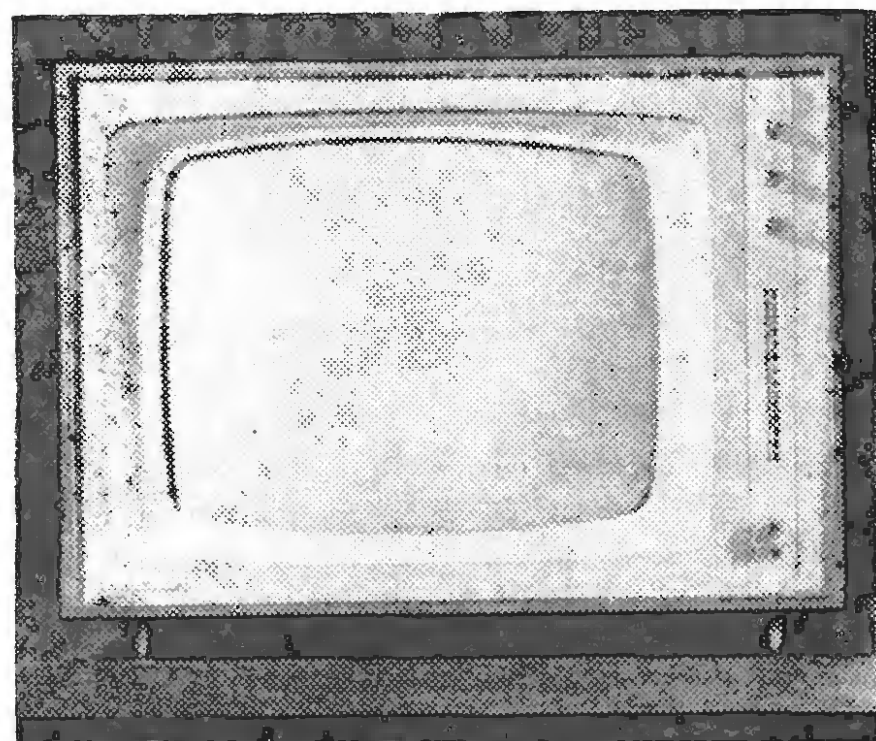

The "Sibylle 108" television receiver which has a 59 cm screen.

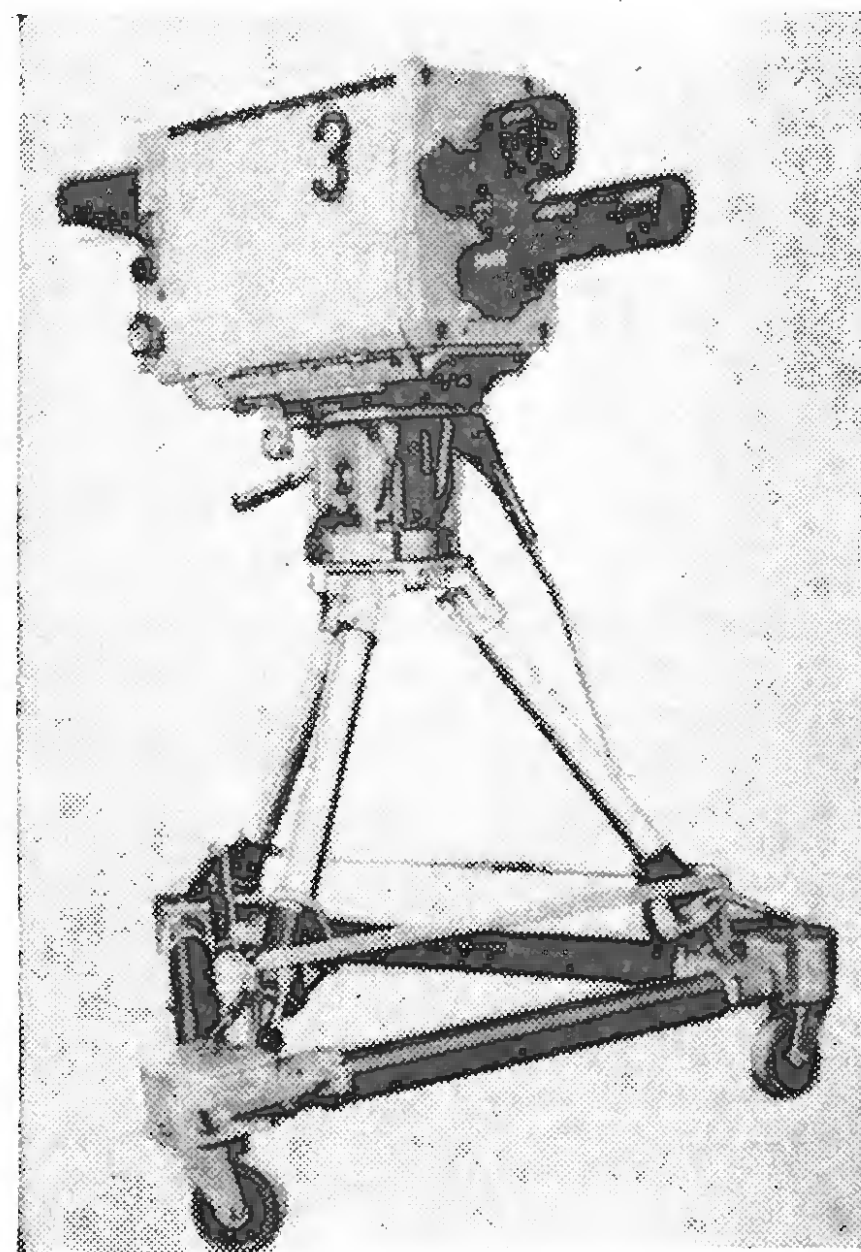

R.F.T. television camera FUK/5.

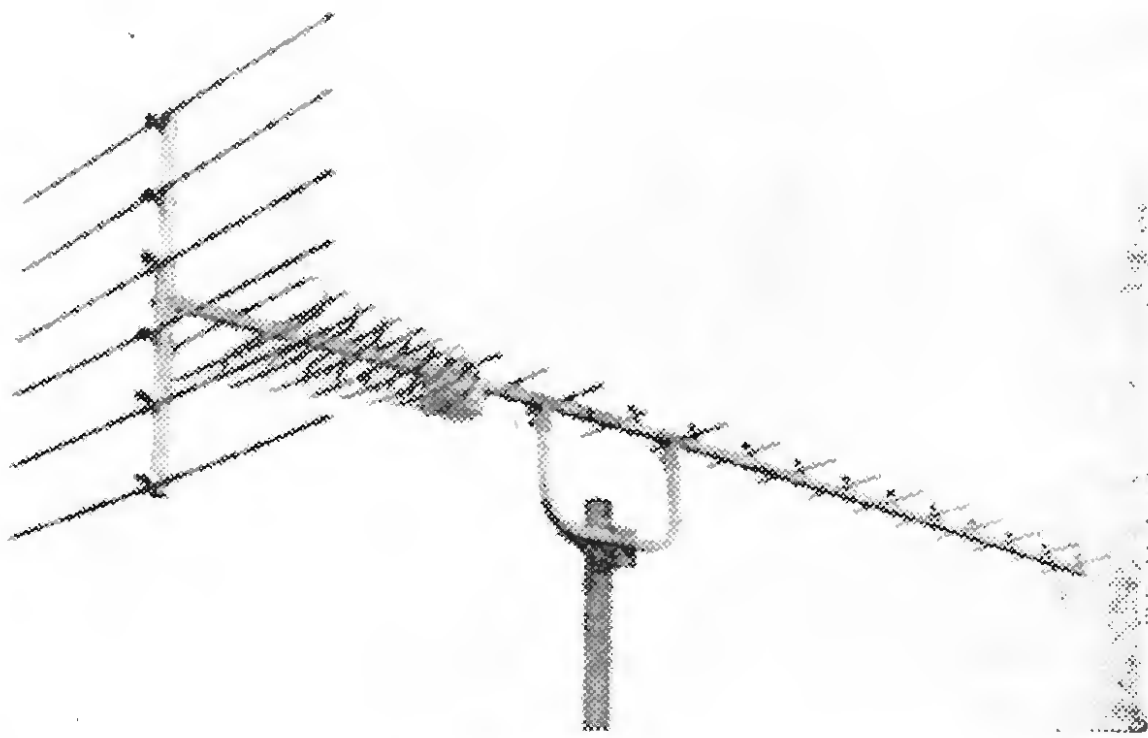

Wideband 28 element u.h.f. television aerial.

Russian dominated countries. The colour rendering bears a strong resemblance to the local colour photographic film ("OR/WO Color") and so should find acceptance.

Prices of black-and-white television receivers in East Germany are surprisingly high—in fact they approach the estimated prices of colour receivers in the west. Typical price tickets (converting at MDN 11.6 to the £)

seen in the Central Store in Leipzig were 43cm "Marion" £140; 53cm "Sibylle" £160; 53cm "Stadion IIZ" £173; 53cm "Kosmos IV" £299. The average good table model radio set costs about £65, a radiogram (which in the U.K. might sell for £60) is priced at £210 and a miniature pocket transistor set "Mikki" costs £65. A tape recorder which might sell for £30 in England was priced at £97.

Among radio receivers and radio gramophones the various cabinet stylings for foreign markets proved the most interesting feature. Portable and pocket transistor receivers are also in production.

A start has been made with stereo experimental transmissions from the East Berlin station, but there is no regular service.

There is an indigenous component industry including valves and semiconductors and also a department for the production of (and we hope may be forgiven for using the term) capital goods, including transmitters, studio equipment and TV cameras.

Although the chances of selling British receivers in East Germany are slim we think that it might be worth while for some firms to set up a stall in this 800-year-old caravanserei if only to catch the eye of visitors from other countries who make the annual visit to Leipzig for either the spring or the autumn Fair where for centuries the merchants of the east and the west have met at the crossing of their ways.

## "The National Plan"

THE country's National Economic Development plan covering the next five years, announced on 16th September in the form of a White Paper (Cmnd. 2764), reiterates the Feilden Committee's\* conclusions: the application of technology depends to a very large extent upon engineers; and many of the weaknesses of British industries and their failure adequately to meet foreign competition can be attributed to a shortage of engineers and to insufficient attention to the importance of engineering design. The White Paper continues: "There is much evidence that the engineering professions generally, and design activity particularly, are failing to attract a sufficient share of the ablest school-leavers and university graduates. One of the important tasks given to the Ministry of Technology is the difficult long-term assignment of co-ordinating activities which will help to raise the status of engineers, improve their training and make their employment in industry more effective. Much of the Ministry's programme in this field involves the implementation of the recommendations of the Feilden Committee in co-operation with other Departments and organizations. . . . The formation of the Engineering Institution's Joint Council marks an important step by the engineering professions themselves to raise their professional standards and standing and to co-ordinate training and conditions of entry to the professions."

"Technological change and the state of technical awareness in user industries are the major determinants of the output of the electronics industry," according to the annexe to the report which was prepared under the guidance of the Electronics Economic Development Committee. ". . . The British share of world trade in electronics has been falling at the same time as the share of imports in the home market has been rising. Competition is strong both from American firms in advanced equipment, particularly in computers, and in simpler products from the Far East. European competition is also increasing."

Although the British electronics industry cannot expect

the same sort of backing the Americans receive from their government, the White Paper states, "It is important that total expenditure by the British Government on electronics, particularly on civil R. and D., should continue at a high level and that the maximum yield in terms of competitiveness should be obtained from it." As regards this field the E.D.C. states that "Adequate support must be given to basic research in the universities . . . and the R. and D. done within the Government should not be tied narrowly to military requirements; it should extend into the civil field and fit in with a common R. and D. policy worked out in collaboration by government and industry."

## Specialist Courses

The following educational centres have sent us details of their specialist courses commencing in October and intended for qualified engineers.

**Northern Polytechnic, London, N.7.**—Beginning on the 1st, 26 evening lectures on The Principles of Modern Network Theory; beginning on the 4th, 25 evening lectures on Colour Television Engineering; beginning on the 6th, 23 evening lectures on Transistor Engineering; beginning on the 21st, 15 evening lectures on Audio Engineering Measurements.

**West Ham College of Technology, London, E.15.**—Beginning on the 12th and extending over two evening terms, Theory and Practice of Automatic Control.

**Wandsworth Technical College, London, S.W.18.**—Beginning on the 12th, nine evening lectures on Integrated Electronics.

**Bristol College of Science and Technology.**—Beginning on the 19th, for three full days, Gaseous Electronics and Plasma Physics.

**Twickenham College of Technology.**—Beginning on the 1st, 12 evening lectures on Transistor Circuit Design.

\* Department of Scientific and Industrial Research Committee on Engineering Design, which reported in 1963.

# Paris Radio Show

## PORTABLE TRANSISTOR TELEVISION SETS THE MAIN ATTRACTION

**T**HE second *Salon International Radio-Télévision* held in Paris in September was not what might have been expected from the title. It was essentially a French radio show, designed to sell domestic equipment to the French public, who flocked in their thousands to the Parc des Expositions, attracted by the free entertainment provided by the shows in the television and sound studios, the "pop" stars signing autographs, the pool for radio-controlled model boats and all the other fun-of-the-fair. Of the 209 exhibitors, about 170 were companies of the French radio industry, while the remaining 40 were foreign firms with already established commercial representation and retail outlets in the French market (18 German, 9 Italian, 6 American and others). Only one British manufacturer, Pye, was to be seen.

Television sets seemed to attract the greatest amount

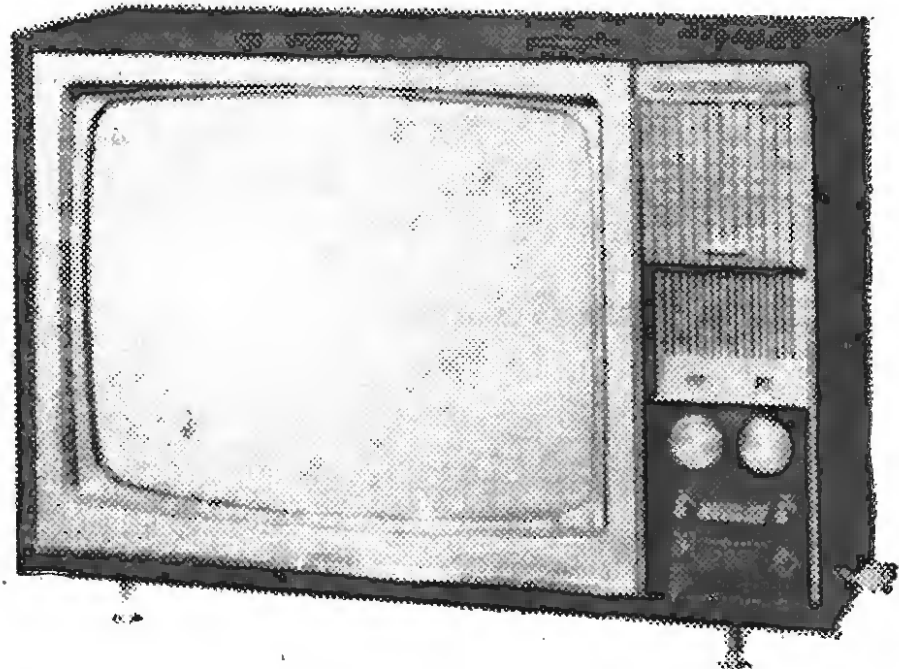

Typical 59cm dual-standard set (Ducretet Thomson) with transistor u.h.f. tuner, photocell contrast control, video response adjustment and piano-key station-selection.

of interest. Since the last *Salon* in 1963 the second television network, 625 lines on u.h.f., has become well established (16 transmitters already installed and 10 more by the end of the year) and all receivers are now equipped for dual-standard, 819/625 lines, operation. As in Britain, the transistor u.h.f. tuner is a common feature. Screen sizes are, in the main, 59 cm (23 in) and 65 cm (25 in), and most sets use tubes with steel bands for protection against implosion (*autoprotégé*).

Apart from the usual controls, many French sets have gadgets such as automatic photocell control of contrast to suit room illumination; piano-key switches for station selection; and "image relief" control of video frequency response, allowing adjustment of the strength of contour marking with different types of programme material. Other novelties were pedestal-type adjustable stands with wheels, and ultrasonic remote control of on/off, station selection and sound level.

The multi-standard television receiver for use in frontier areas is, of course, a familiar object at European radio shows and at Paris most of the larger manufacturers had two or three sets in their normal range. Several of the French-made sets will receive the French (14 Mc/s), Belgian (7 Mc/s) and Luxembourg (7 Mc/s) 819-line

transmissions on v.h.f., the French 625-line second programme on u.h.f., the Belgian 625-line transmissions on v.h.f., and the European (7 Mc/s, f.m. sound) 625-line broadcasts on v.h.f. from Germany, Switzerland, Italy and Spain. British 405-line pictures can be received on some sets made by Grammont. Apart from all the complex circuitry and switching needed for multi-standard reception, a fairly elaborate aerial system is usually required as well. The old method of turning a handle to rotate the aerial to receive a required station has now been superseded by the remotely controlled electric drive, comprising a motor mounted half-way up the mast and a control box (providing aerial position indication) in the living-room. Belvu were showing a whole range of these controlled drives at prices from about £30 to £150.

What really caught the eye in the television sphere, however, was the large number of portable transistor television sets on show—mostly 11-inch models. A French firm, Radio-Celard, was the first European maker to produce an all-transistor television receiver—a 19-inch table model. It was shown at the 1963 *Salon* and this year the company had a 23-inch all-transistor table model; but in general there has been little activity in this field, perhaps because transistors do not yet offer any advantage in price over valves. For portables, however, the transistor obviously allows a worth-while reduction in size and power consumption, and it seems clear that the French manufacturers have concentrated on the possibilities of this sector of the market. Some of the sets on view were Japanese, and it was rumoured that a few of those with Continental brand names were of Japanese manufacture also. The smallest of the television portables was a Sony 5½-in model, weighing about 9lb (see photo), which has only recently been introduced into Europe. Like the larger portables, it will operate from a 12-V battery or

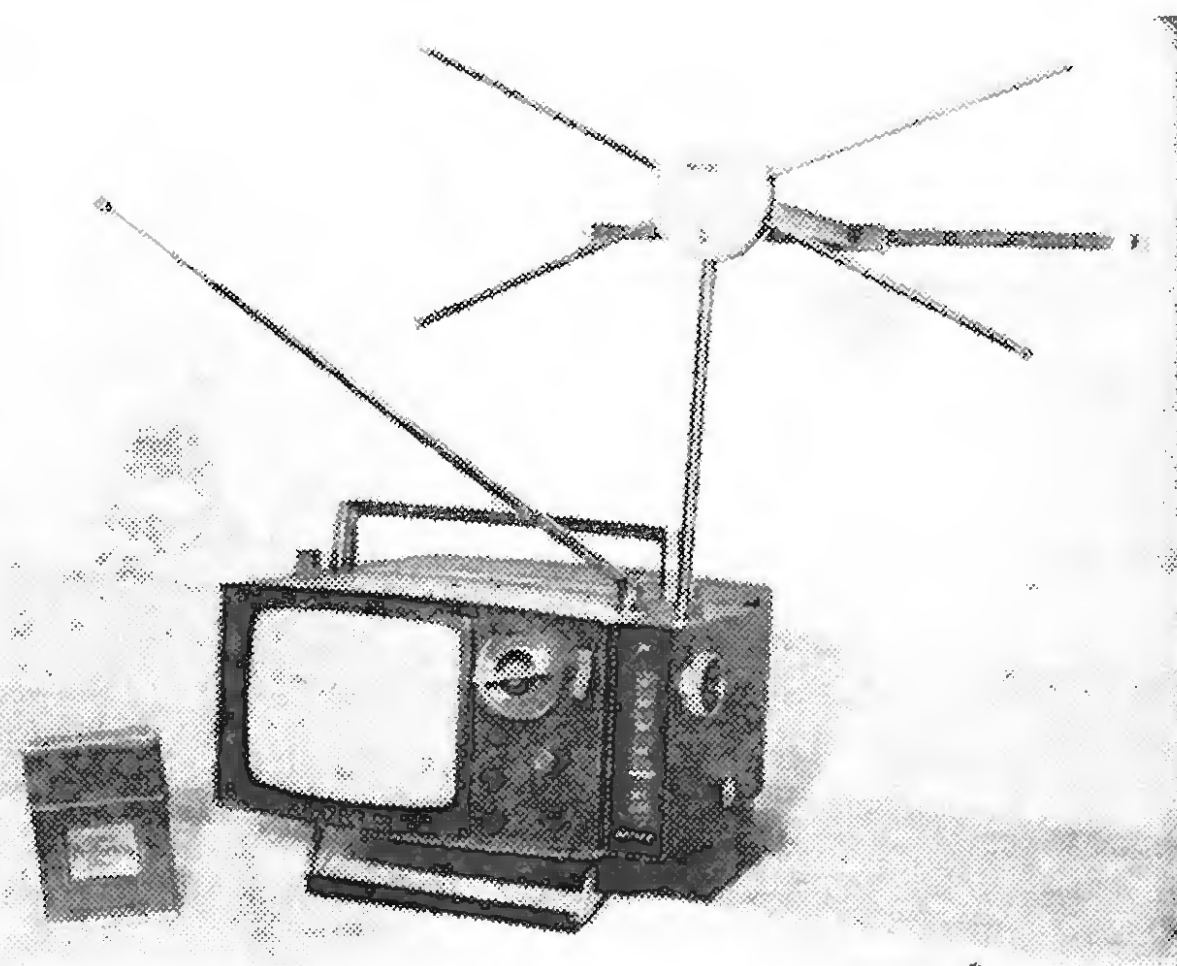

Sony transistor portable showing telescopic v.h.f. aerial and u.h.f. adaptor (right) with its plug-in foldable aerial.

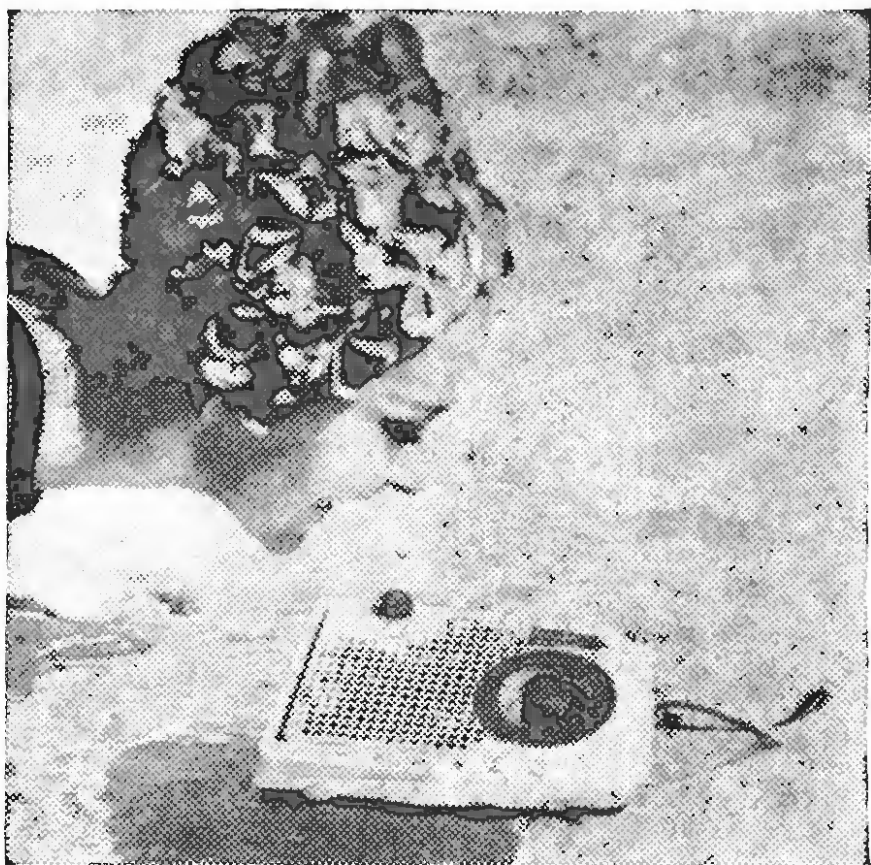

In the swim. The Voxson "Zephyr" transistor set floating in a swimming bath. A sealed plastics case encloses the receiver unit.

220V a.c. mains, but has a detachable u.h.f. tuner with a plug-in aerial for the French second programme. On the back of the set is a row of four push buttons for standards selection, allowing a choice of French or Belgian 819-line or 625-line systems or the European 625-line system.

Colour television was noticeably absent—no demonstrations, no SECAM receivers.

In October the O.R.T.F. experimental stereophonic sound broadcasts in France will be replaced by a regular

service of eight stereo programmes a week on the *France-Musique* f.m. network. Transmissions will continue to use the pilot-tone system and will be receivable in the service areas of the Paris, Gex, Lille, Clermont-Ferrand, Lyons and Marseilles stations. In spite of this, the *Salon* bore evidence of remarkably little response from the set manufacturers. Certainly some of the two-channel radiograms incorporated stereo decoders and, of course, the majority of the *haute fidelit * installations were suitably equipped, but there seemed no sign of more general exploitation. One interesting novelty was a small Sony a.m./f.m. portable transistor set (about 7in×5in×2in), available with a separate stereo adaptor of similar size, containing a decoder and second loudspeaker. Considering the small size of the units and the spacing used to demonstrate them—about 2ft—the sounds produced were quite respectable. Demonstrations put on by the O.R.T.F., using high-quality commercial equipment, gave very agreeable reproduction of the specially arranged stereo music broadcasts, but the effect was not markedly different from that of two spaced loudspeakers working from a single channel.

Three transistor set novelties: remote control (by wire) of station selection and volume on a Telefunken receiver; a Voxson portable set which floats—you throw it in the water when you go for a swim; and a really small pocket superhet receiver (m.w. only) by Standard, measuring 2 in×1 $\frac{5}{8}$  in× $\frac{7}{8}$  in, with a 2 in×1 $\frac{3}{8}$  in loudspeaker.

N.B. (*Note Bacchanale*): Some French manufacturers seem to measure the capacity of their loudspeaker enclosures (*enceintes*) in litres—perhaps understandable in a nation so appreciative of wine, women and fast cars.

## Video amplifier with thermal feedback

THE usual method of achieving a fall in amplitude response in an audio or video amplifier is to utilize the coupling capacitors. But these components are bulky and their use with microelectronic circuits is inelegant, to say the least. A microelectronic differential amplifier (SNX1303) with a bandwidth of 50 c/s-10 Mc/s has been developed by Texas Instruments Inc., which uses no capacitors and is contained within two standard  $\frac{1}{4}$  in× $\frac{1}{8}$  in flat packs.

The amplifier consists of a thermal feedback stage and a

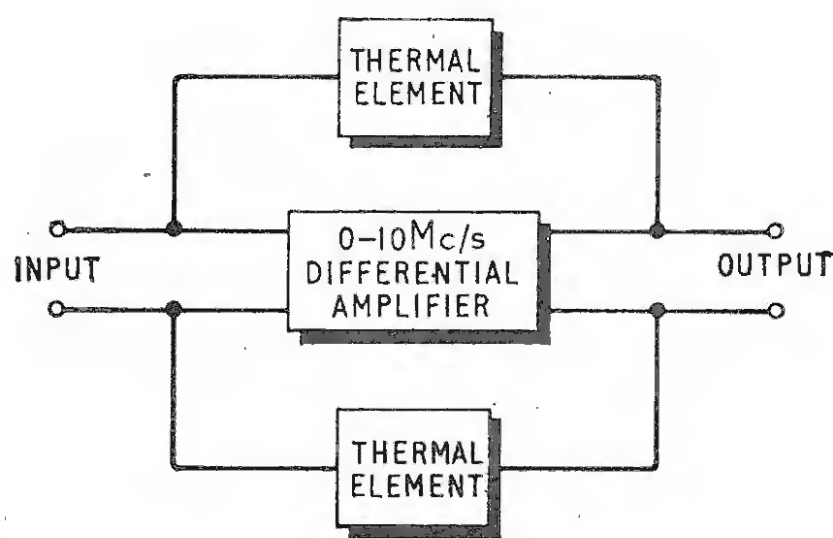

Fig. 1. Thermal feedback loops with low-pass filter response give an overall response of 50 c/s—10 M/cs.

differential amplifier, both using normal diffused-silicon integrated circuitry. The feedback loop is thermal and will consequently have a low-pass characteristic due to its relatively slow response. The size of the thermal element is chosen to give a 3 dB frequency of 50 c/s and the maximum attenuation is 32 dB.

The heater component is the emitter resistor (R) of an emitter follower which is fed from the output of the d.c. amplifiers (see Fig. 2). The sensing element, on the same silicon substrate, consists of two negative temperature coefficient diodes, one being the base-emitter junction of an emitter follower for convenience (on left of Fig. 2).

The heater resistor operates at 25°C above ambient temperature and the design allows for a temperature swing of  $\pm 25^\circ\text{C}$ .

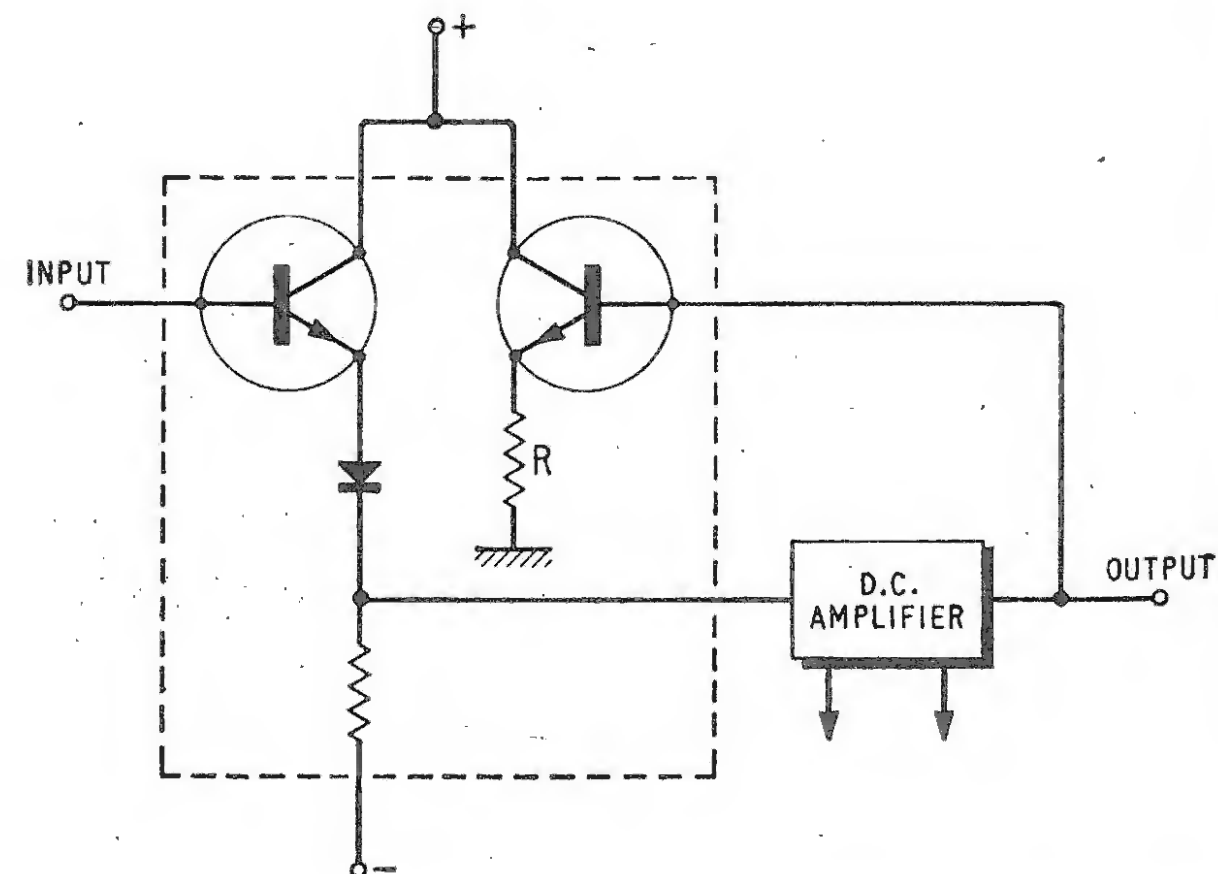

Fig. 2. Basic arrangement of one of the feedback stages, the box enclosing the thermal feedback elements.

# Slow-motion Television

By M. LEEUWIN

**Japanese television broadcasting technique for slowing or arresting events of special interest. Uses a modified video tape recorder and a special magnetic tape storage unit.**

**D**URING the 1964 Olympic Games in Tokyo excellent televised reports of the games were relayed from Japan to the rest of the world via the Syncom 3 communications satellite. Special professional interest was aroused in Europe by the technique that was used to repeat certain events in slow motion, enabling viewers to see precisely what happened. At certain crucial moments the motion was arrested to make the picture a "still".

This slow-motion effect, combined with the possibility of quick selection at random of any recorded scene, has been achieved by the use of modified video-tape recording equipment. The instrument, specially developed for the 1964 Olympic Games by NHK (the Japan Broadcasting Corp.) in collaboration with the Nippon Electric Company, Shiba Denki and the T.E.A.C. Corp., is based on standard Ampex equipment. It is capable of playing back, 15 seconds after recording, a "slow-

motion" picture, a stationary picture of any selected transient image or a combination of both.

Although the machine gave satisfactory performance during the games, various improvements, mainly in connection with stability of operation and useful life of important parts, have been subsequently made. Slow-motion scenes are now being incorporated in NHK programmes as a regular item.

**Operation of system.**—In order to understand the operation of this slow-motion system, one must be aware of the following basic requirements:

1. The slow-motion effect has to be obtained from a standard recorded magnetic tape.
2. The speed of rotation of the recording/reading head of the standard V.T.R. has to remain unchanged.
3. The television transmitter and receivers in the field have to accept the slow-motion picture without any modifications.

The technique adopted to meet these requirements is to repeat every picture field five times. For still pictures, each field is repeated an indefinite number of times. A repetition of five times has been chosen for slow-motion operation because tests have shown this to be the most desirable compromise; other repetitions having introduced complications. This cycle of repetition is "built into" the machine and cannot be changed without major mechanical and electrical modifications.

In order to transmit each field five times, a one-field memory unit is used, this being so designed that the field is scanned by the reading heads five times in suc-

*The modified main V.T.R. equipment is shown on the left and the separate one-field memory unit on the right.*

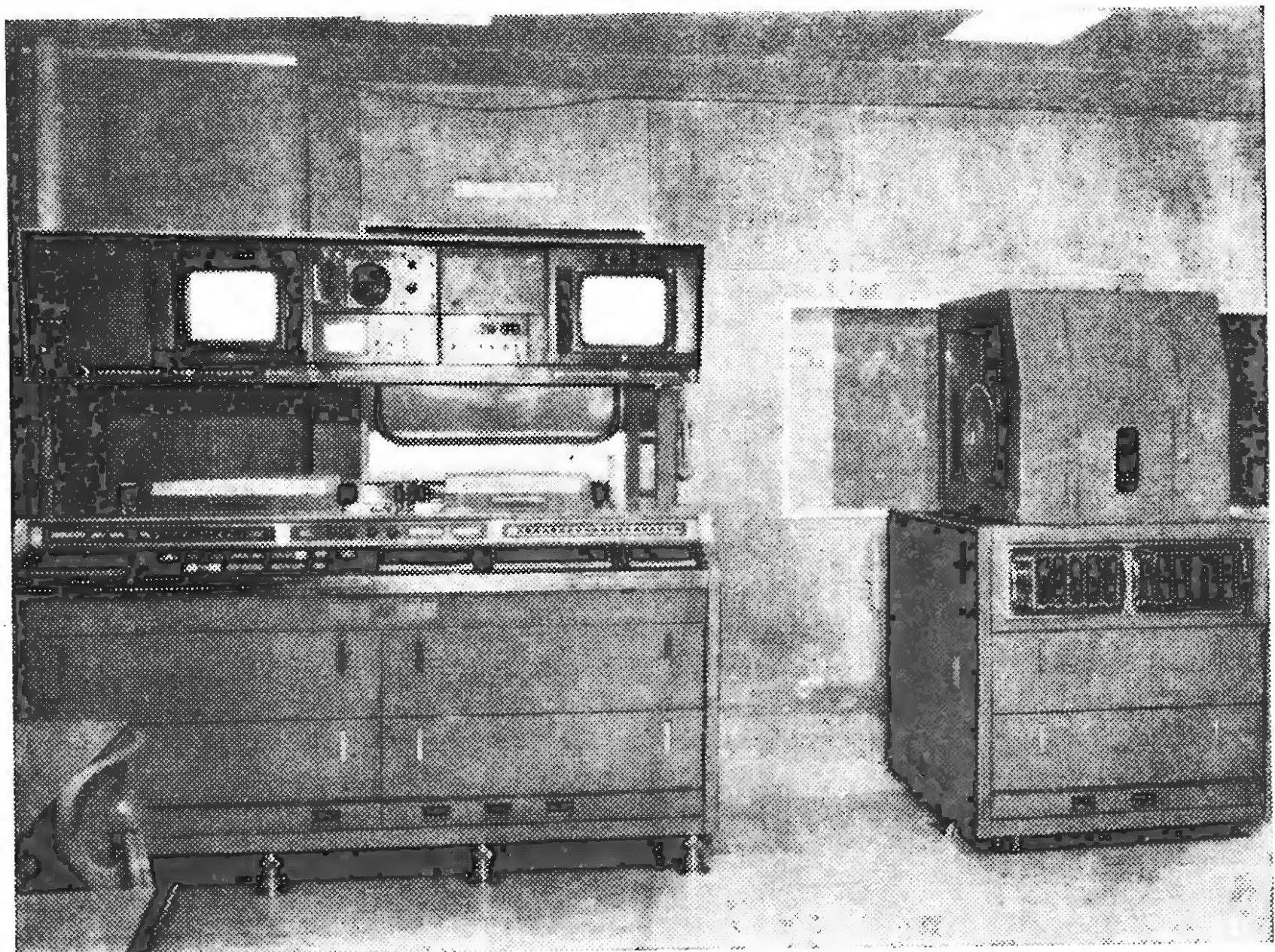

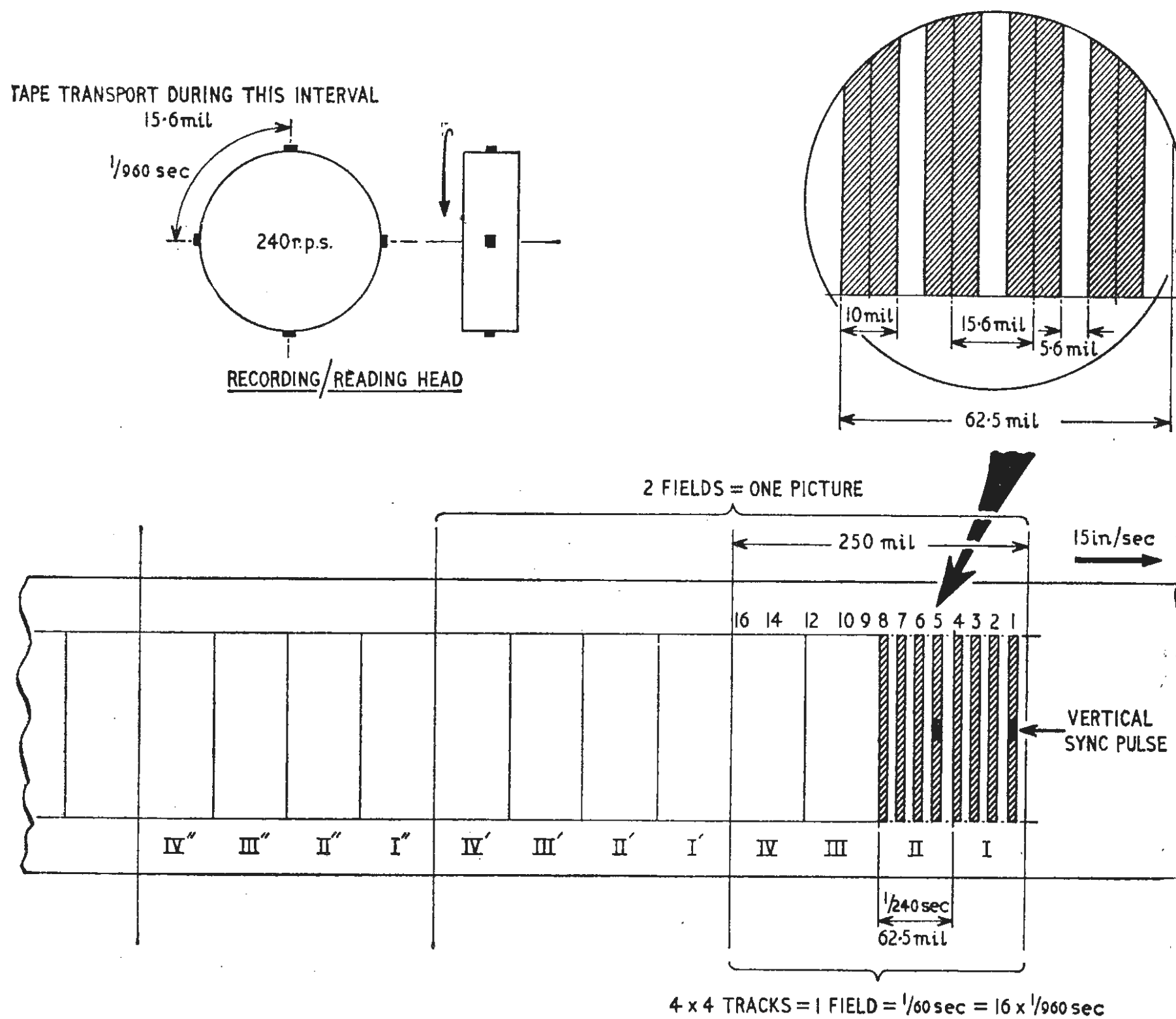

Fig. 1. Recording pattern and head arrangement for standard Ampex video tape recording. Each vertical bar contains the modulation of 16 picture lines, including line and field sync pulses.

cession, a kind of interlacing being restored by a special device. During this interval the reading head of the main V.T.R. unit makes four idle turns. It will be evident that a special method for scanning the standard recording, which for slow-motion operation moves at one fifth of the normal speed, has to be used. This is called intermittent scanning.

**Intermittent scanning.**—Normal scanning in the standard Ampex unit is performed by four reading heads mounted in the same plane in the revolving drum, which scans the tape transversely. The tape speed is 15 in/sec and

the rotational speed of the drum is 240 revs/sec. Fig. 1 represents the situation at this standard tape speed.

At slow speed the tape travels at one fifth of normal speed, that is 3 in/sec. In order to obtain at this slower speed the normal track scanning rate, the artifice of offset scanning heads has been adopted. This means that the reading heads of the slow-motion V.T.R. machine are not arranged in one plane but in four different planes, the spacing being 12 mil. (1 mil. = 0.0001 inch.) Offsetting is necessary because each head has to make in each quarter revolution ( $1/960$  sec) a "retrograde" movement with respect to the movement of

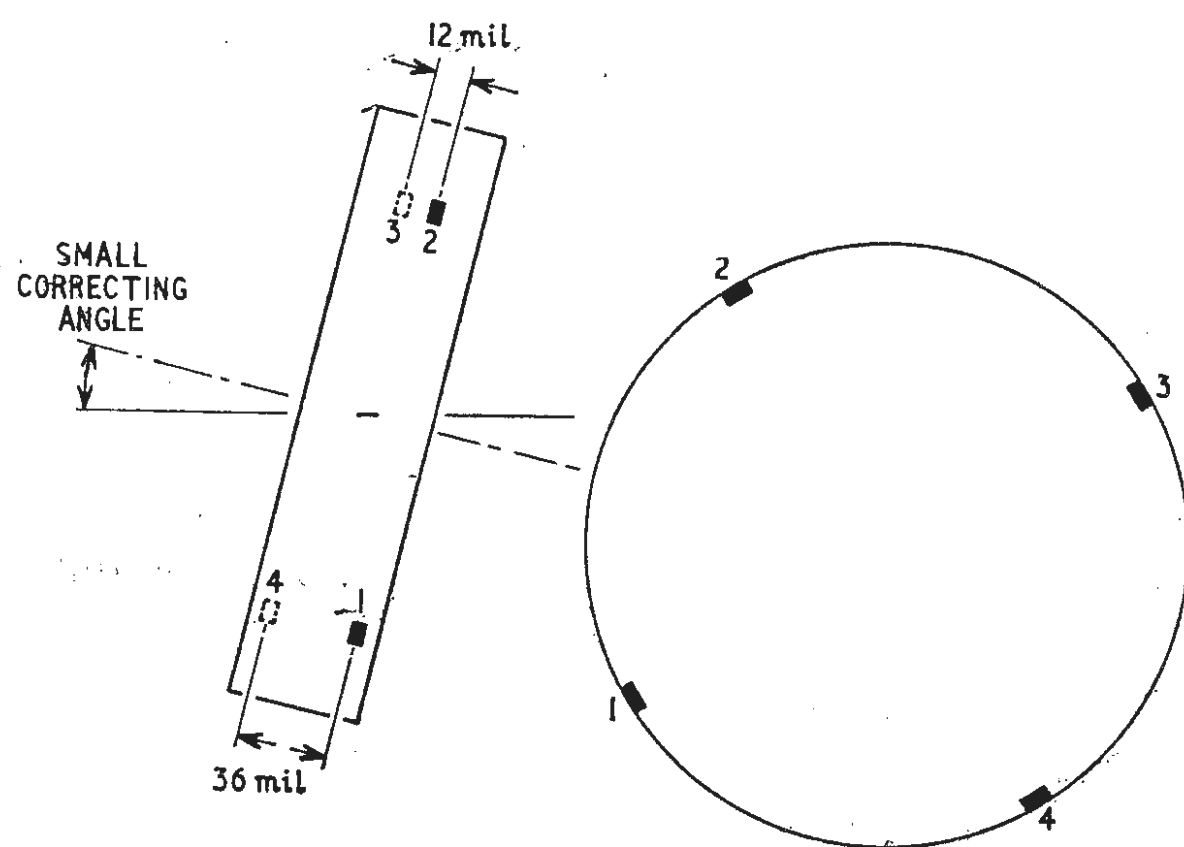

Fig. 2. Offset arrangement of heads on the skewed scanning drum of the modified V.T.R. equipment.

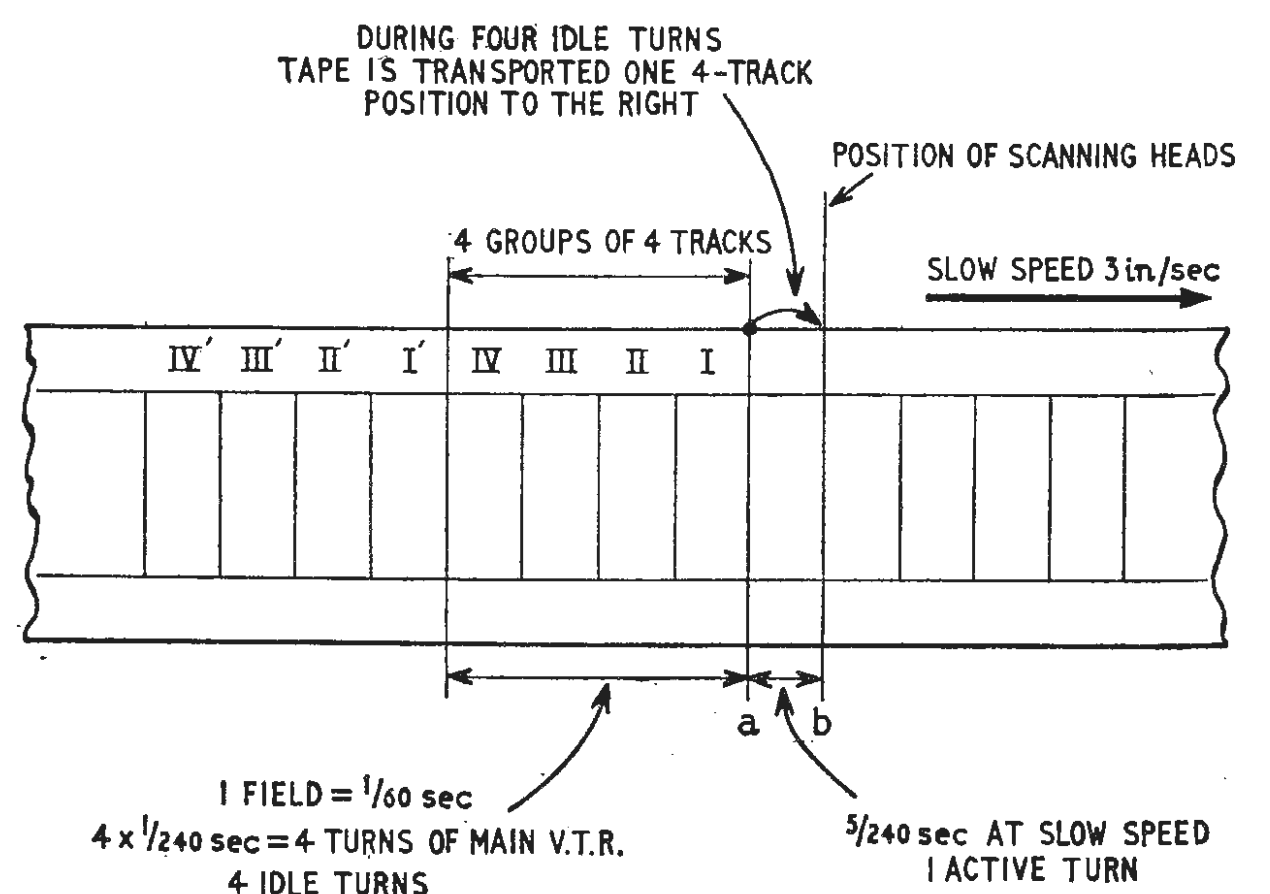

Fig. 3. Showing the action of intermittent scanning with reference to standard tape recording.

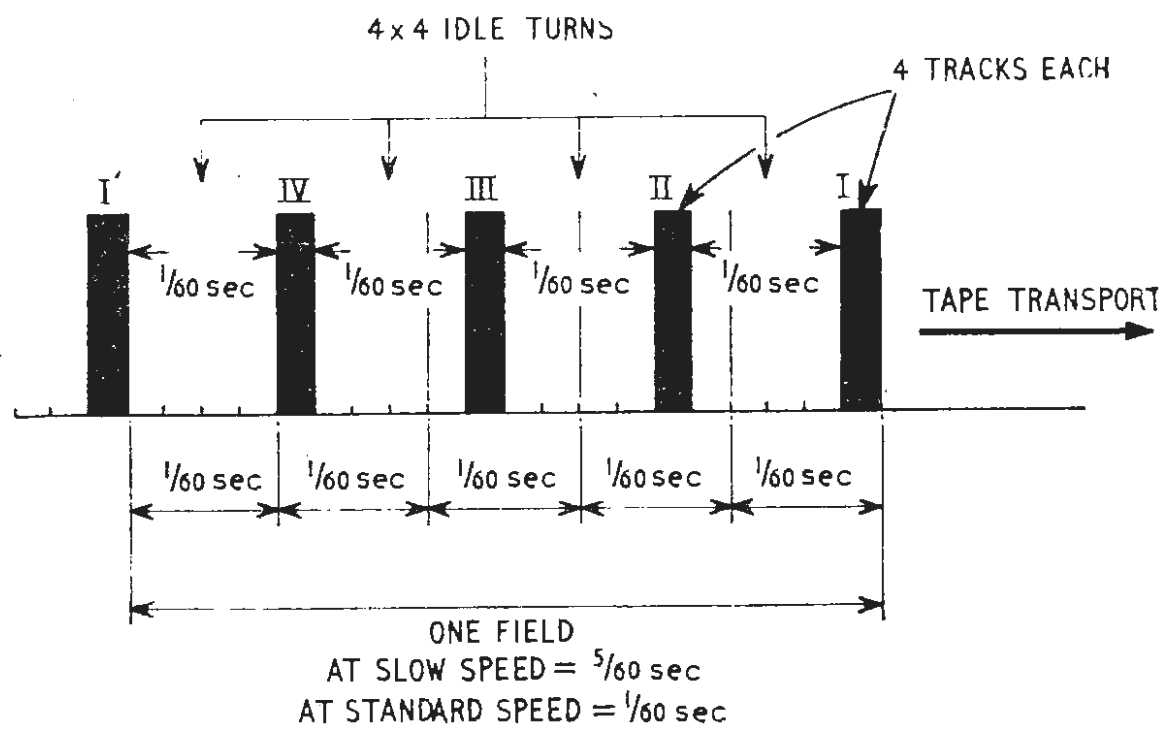

Fig. 4. How the modulation of one field is translated into four bursts of 4 tracks each, as a result of intermittent scanning on the modified Video tape recorder.

the tape of one "interval", a distance of 15.625 mil (see Fig. 2). The movement of the tape at slow speed during each quarter-revolution of the head drum however, is  $1/960 \times 3000 \text{ mil} = 3.125 \text{ mil}$ . This leaves to be compensated for a distance of  $15.625 - 3.125 = 12.5 \text{ mil}$ . The slight difference between this required distance and the head spacing of 12 mil is taken up by various compensating factors. In order to compensate for the difference in effective slant between recording and reproduction, the reading head drum is skewed at a small angle.

By the offsetting of the heads, during each revolution of the head drum a group of tracks is scanned at slow tape speed; four active revolutions plus 16 idle revolutions of the drum giving one field.

**Idle turns.**—By the artifice of the offset heads the effect of a five-fold increase of forward tape speed is achieved. Although the actual tape speed is only 1/5 of normal speed four tracks are scanned in 1/240 sec. The time needed for the next group of four tracks (in the retrograde sense) to move up to the scanning position of head No. 1, from *a* to *b* in Fig. 3, is 5/240 sec., i.e., five turns minus one active turn=four idle turns. This is allowed for by periodic electronic gating of the amplifier.

The "fields" of the standard tape, although recorded and read out at the standard scanning rate, now appear in the V.T.R. read-out signal as bursts of four tracks each, separated by intervals of four times the duration of one burst. The sequence is shown in Fig. 4. The desired retardation factor of 5:1 being obtained, and the tape modulation nevertheless being scanned at the standard rate, the basic requirements listed earlier have been fulfilled. The next step is to store this information in the one-field memory unit. In this unit, as already mentioned, each field is read five times in succession, thereby giving the desired effect of continuous motion at slow speed, or, if so desired, a still picture by an indefinite number of repetitions.

**One-field memory.**—In this storage device a similar general technique as in the main V.T.R., with standard video tape and rotating heads, is used, but the device is a self-contained separate unit. The tape, however, does not move (except at intervals to compensate for wear), the tracks being at a rather small angle. There are two self-contained recording/reading assemblies in the unit, one at each end of the shaft of a driving motor, and these are used alternately for recording and reading.

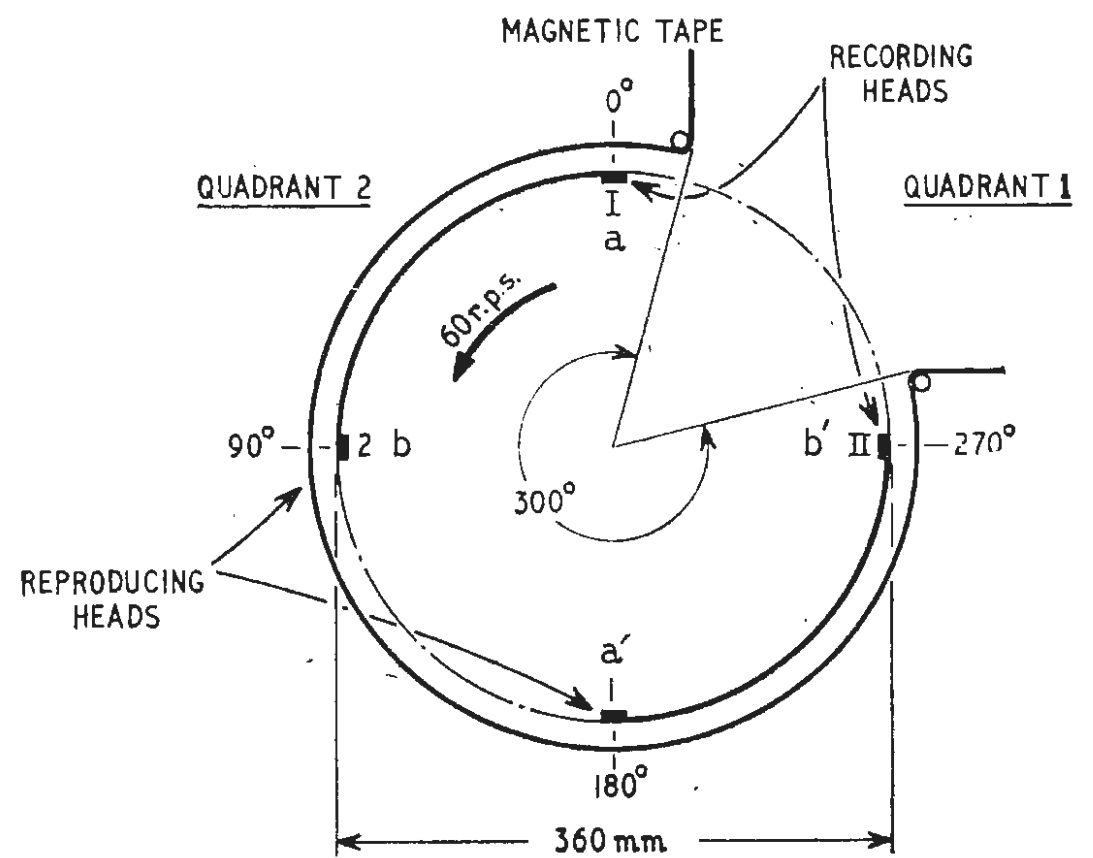

Fig. 5. Arrangement of recording and reading heads and magnetic tape in one drum assembly of the memory unit.

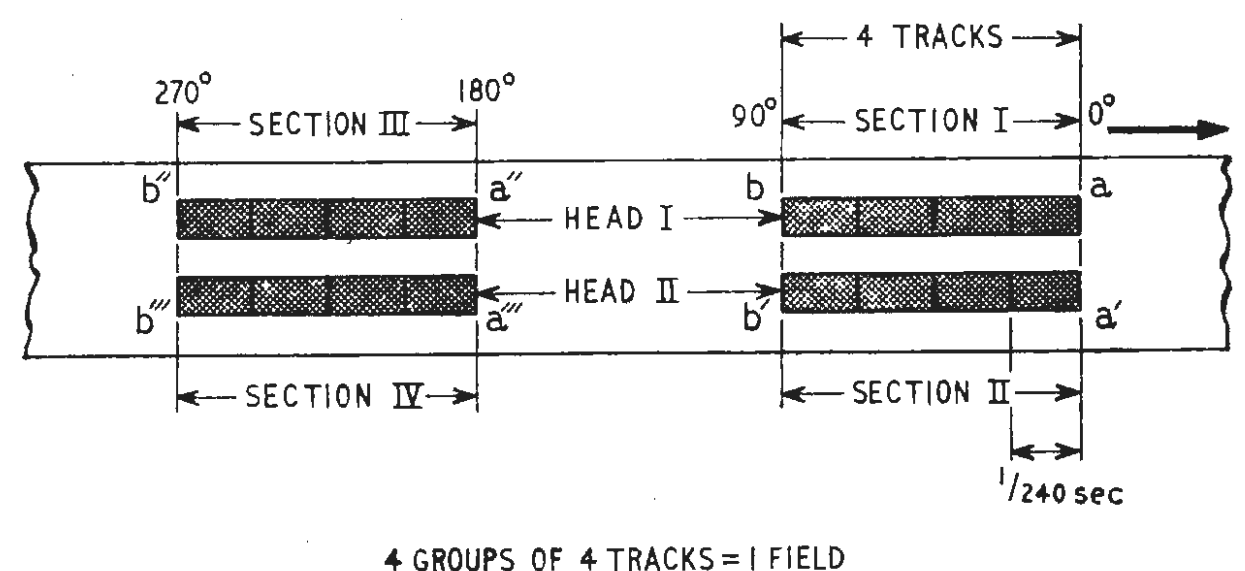

Fig. 6. Magnetic pattern on the semi-stationary tape in the memory unit. The tracks are actually slanted at  $2^\circ 54'$  to the edge of the tape.

On the revolving head drum of each assembly two pairs of heads are mounted, one pair for recording, the other for reading, as shown in Fig. 5. From this diagram it can be seen that the first and third quadrants of the drum are inoperative, the tape being fed in in quadrant 1 during intervals.

Not shown in the diagram is the fact that in quadrants 1 and 3 the tape is cleaned of magnetic and other dust particles by the wiping action of a secondary moving tape, which acts as a "broom" in contact with the recording tape. Moreover, in quadrants 1 and 3 some extra lines of video information are recorded for overlapping during reproduction.

Frequency modulation is used, with a carrier frequency of 6.4 Mc/s and a deviation of  $\pm 1 \text{ Mc/s}$ . This particular carrier frequency has been chosen to make it possible to superimpose successive recordings of a field without erasure. Experimentally it has been found that with this frequency at 1 Mc/s off carrier, the remaining modulation on the tape during superimposition is 35 dB down, which is sufficient. Without knowing this, it is difficult to understand the operation of the memory unit.

The intermittent signals arriving from the slow-motion reading section of the main V.T.R. unit are distributed to the respective recording heads of the memory unit by a switching circuit and amplifier.

For recording, one pair of heads is so positioned and switched that each head covers one trace, there being two traces and four sections altogether. The shaft of the head

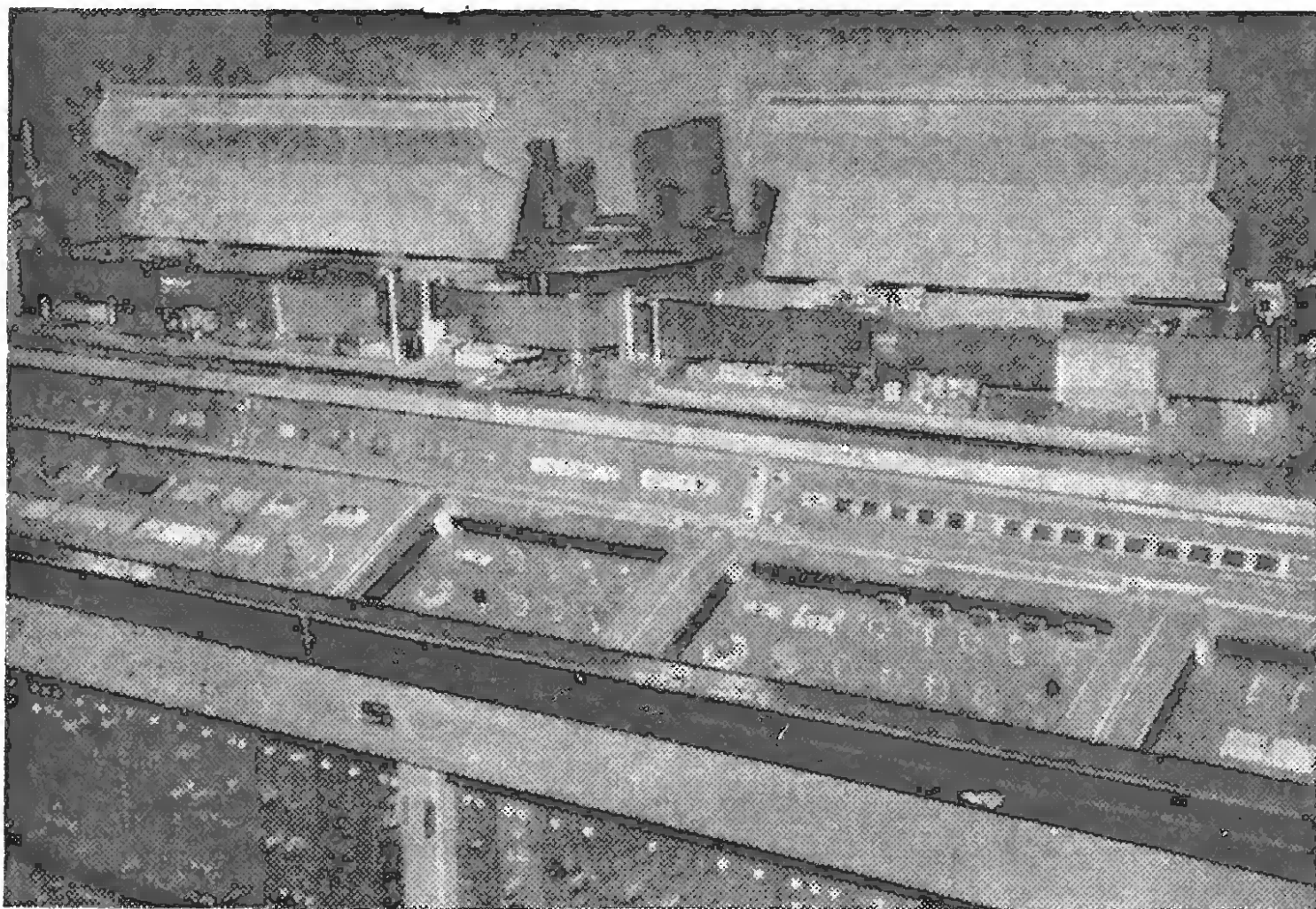

*Tape transport of the modified video tape recording equipment, showing standard-speed recording section on the left and slow-motion playback section on the right.*

assembly rotates at 60 revs/sec, a quarter of the speed of the slow-motion V.T.R. playback heads. The diameter of the revolving drum in contact with the tape is 316 mm, while its circumferential speed is 60 metres/sec. The tape, at an angle to the tracks, covers about 300° of the circumference of the drum. The resulting pattern on the tape is shown in Fig. 6. While the signal of section I, consisting of four tracks (one revolution of reading head drum on slow-motion V.T.R. machine) is fed to the recording head I and recorded, the drum of the memory unit assembly travels through an angular distance of 90° only. This gives the trajectory *a-b*.

After completion of 90° rotation, recording head II of the assembly is in position for section II, and starts recording between *a'* and *b'*. As a result of the positioning and switching of the two recording heads, the next sequences are section III, *a''-b''* and section IV, *a'''-b'''*. Although not represented in Fig. 6, the four idle turns of the head drum on the slow-motion machine take place in the intervals between the trajectories *a-b* and *a'-b'* and so on.

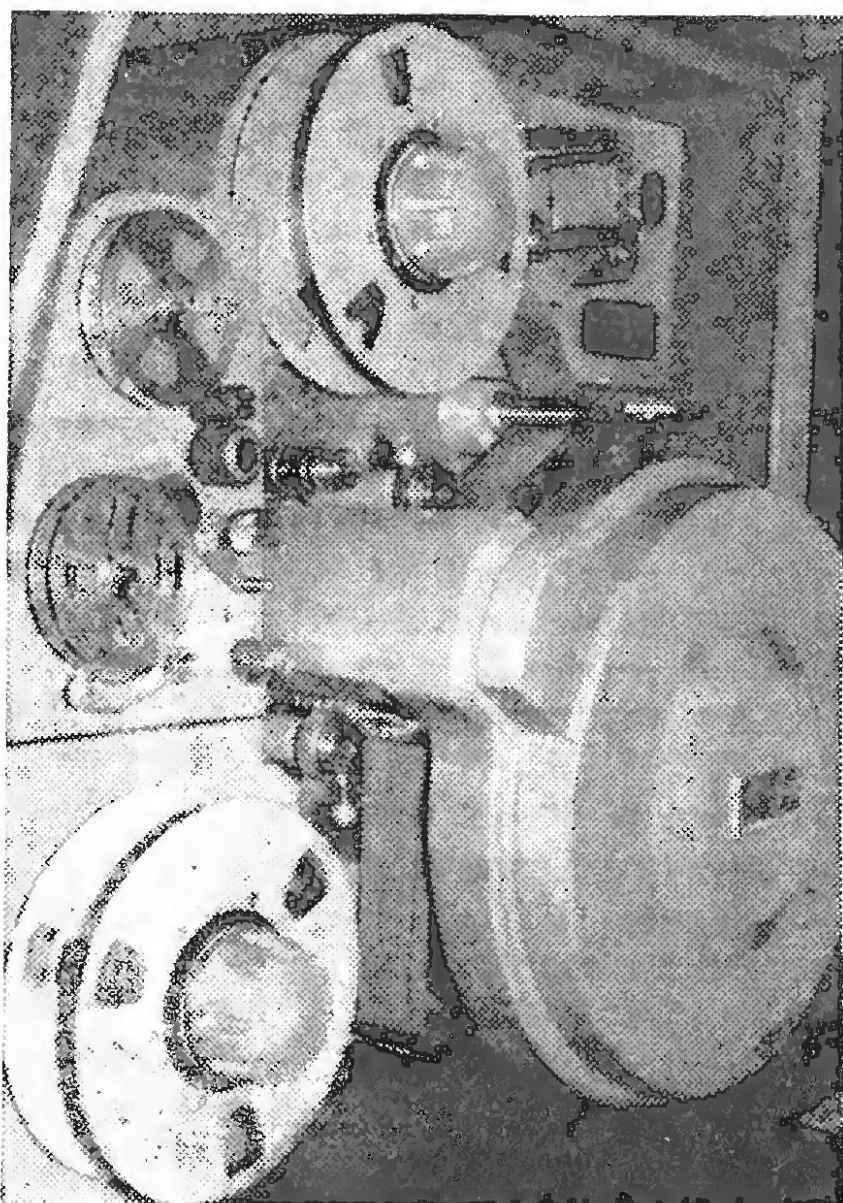

*One drum assembly of the one-field memory unit. The two large reels are for supply and take-up of the recording tape, while the two small reels are for the cleaning tape.*

When the recording of one field is completed the reading heads 1 and 2 start to play it back five times. During this period, the next field is recorded in the other drum assembly of the memory unit. A continuous scanning of the four sections of the one-field recording is obtained, because the blank interval of 90° is compensated for by the 90° offsetting of the heads.

Recording and reading are repeated alternately for successive fields by each drum assembly during each 5-field cycle, and in this way continuous reproduction of the slow-motion picture is obtained. In order to obtain a stationary picture, the movement of the V.T.R. tape is stopped and the recorded field is repeated indefinitely.

**System operation.**—The standard recording is made on a normal V.T.R. The recorded tape is then rewound and played back on the slow tape-speed section of the modified machine. After passing through the one-field memory unit the signals are amplified, sent through a switching unit and finally fed into an f.m. demodulator. The demodulated signals have to be compensated for the line sync pulses, in order to obtain a substitute for interlaced scanning. This has to be done because a slow-motion picture consists of one field only, repeated five times, and without this artifice the picture would contain only half the normal number of scanning lines. This compensation is performed in a field setting circuit, in which the line sync pulses are made continuous by a delay-line switching circuit.

Discontinuities occurring between the groups of four tracks, caused by the residual jitter of the system, are corrected by a variable delay line. A standard video signal is obtained after shaping and correction of the field sync pulses. The main characteristics of the system are as follows:

Slow-motion reproducing ratio	5:1
Output signal resolution	400 lines
S/N ratio	41 dB
Life of slow-motion heads	.. More than 100 hours
Life of memory-unit heads	.. More than 200 hours

**Acknowledgements.**—The author wishes to thank Mr. Tanabe, Mr. Yokogawa, Mr. Yoshikawa and Mr. Matsuoka of NHK for information and for reading the manuscript, and Mr. Hirasawa for discussions and contributions.



# R.E.M.E. School of Electronics

TRAINING ARMY RADIO & ELECTRONIC ENGINEERS

**T**HE task of maintaining the electrical and radio equipment in the Army has over the years passed from the Royal Engineers in the 1914-18 War to the Royal Army Ordnance Corps and since 1942 to the Corps of the Royal Electrical and Mechanical Engineers. It would be true to say that since the formation of the Corps the electronic and radio equipment used by the Army has more than trebled in quantity and it is immeasurably more complex.

Although the Corps is also concerned with the Army's mechanical gear, we must confine ourselves to its elec-

trical interests, 90% of which come within the purview of *Wireless World*, in fact the "E" in the Corps title might well stand for "electronics."

R.E.M.E.'s function is to maintain the equipment of the Army in a fit state for war and to minimize the effect of battle. The Corps training is done through two schools; one "mechanical" at Bordon, Hants, and the other, the School of Electronic Engineering at Arborfield, near Reading, Berks. This school, which handles over 1,400 scholars a year, has recently been rehoused and the new buildings were officially opened by the Rt. Hon. Fred Mulley, Minister of Defence for the Army, on September 15th.

The officers and men in R.E.M.E. are not concerned with operating the equipment but its maintenance, and are therefore primarily engineers and technicians. Moreover, because of its major role in the maintenance of the Army's equipment, it is also deeply concerned with policy in the design and development of future equipment—particularly on the score of reliability.

The new School comprises 25 laboratories, 7 laboratory-lecture rooms and 21 classrooms, plus library, cinema, drawing and printing office and admin. offices. Col. L. C. Libby, M.B.E., the commandant, who has been at the School since 1962 and has played a major part in bringing it to its present academic position, is ably backed by a teaching staff of some 100. The average weekly attendance at the School is about 500 and includes officers, N.C.O.s and other ranks. There are about 70 courses in progress at any one time.

There are two main streams of entry to the School—through the Army Apprentice School comprising about 40% of entrants, and by direct entry. Those taking the second route receive their initial military training and a two weeks' course for the Army Certificate of Education before starting on a 29-week basic electronics course.

After a short military training course entrants via both streams take a 24-week equipment course during which they are instructed in the operation and mainten-

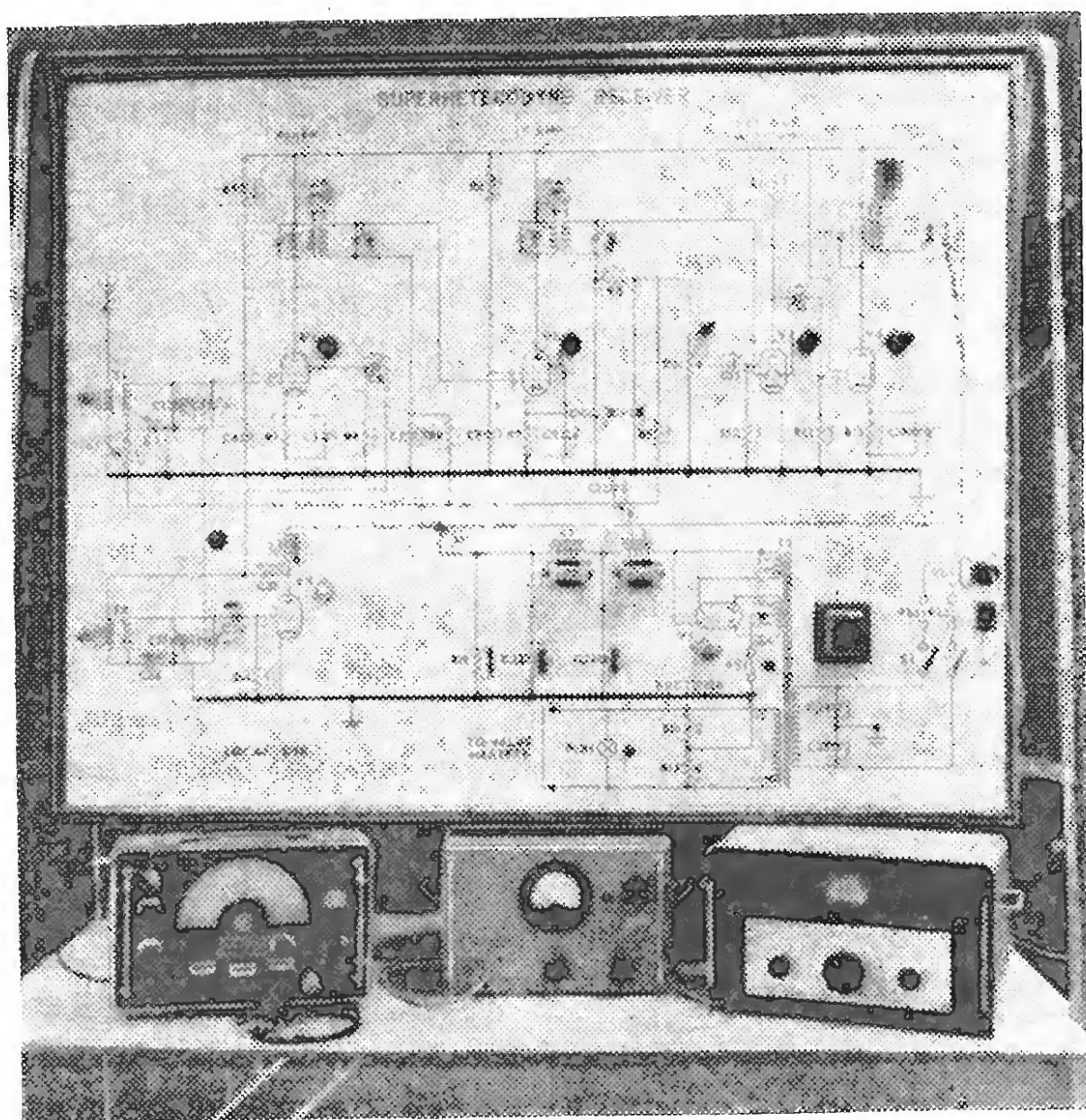

Left.—An operational receiver with plug-in components used, together with test equipment shown, for the demonstration of fault-finding techniques.

Right.—Student's bench with a circuit assembly board designed at the School. Each bench is equipped with a b.f.o., power supply unit, and oscilloscope.

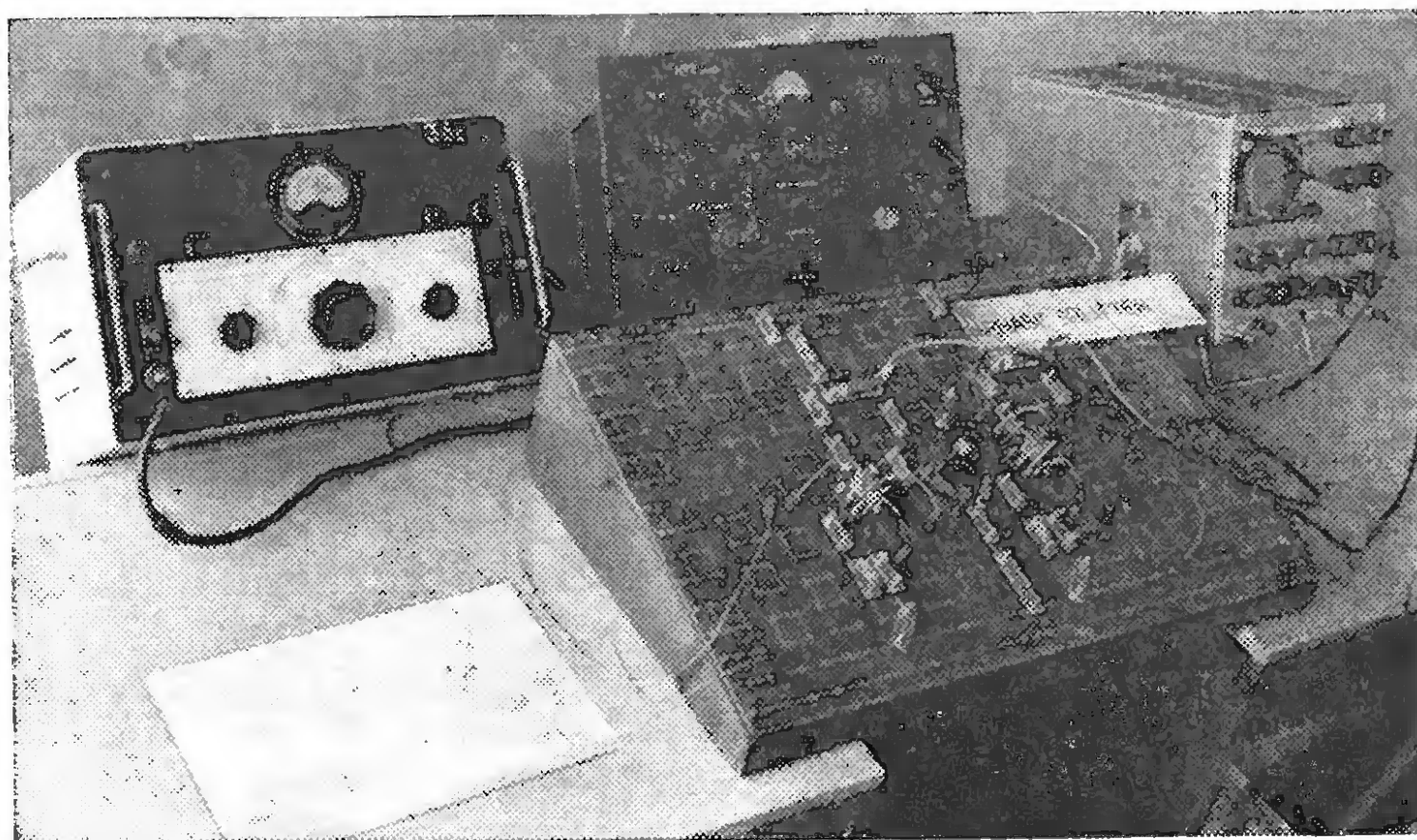

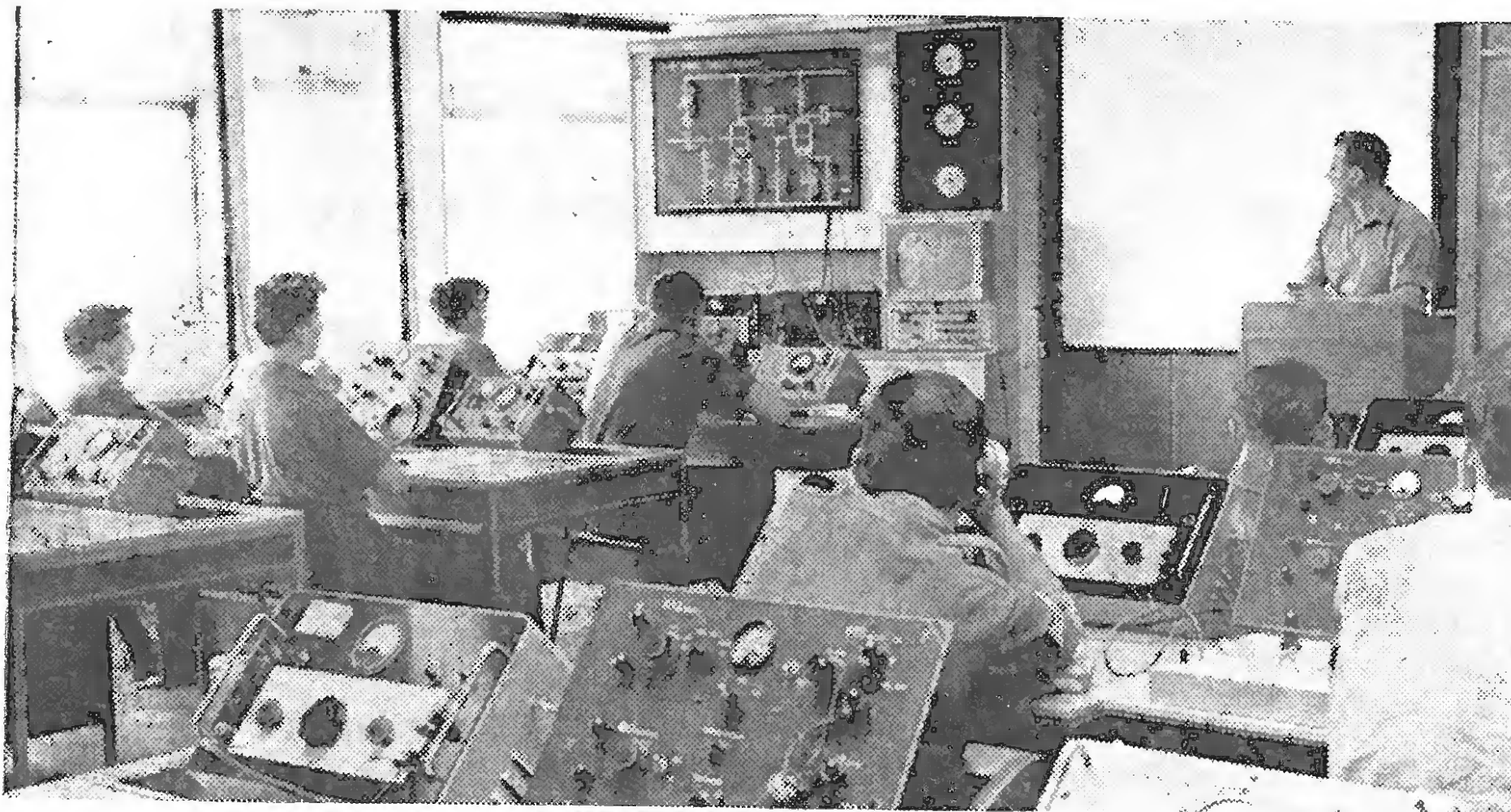

A technicians' class receiving instruction with the aid of a demonstration console, on which a wide variety of circuits with plug-in assemblies or components can be used.

ance of several pieces of standard Army equipment. At the end of this course the successful trainee passes out as a Class II technician and he then goes into the field as a L/Cpl. for two or three years' experience. Depending on the equipment course for which he has been selected he will now be a telecoms technician, control equipment technician or radar technician.

His school days are not over however. He is encouraged to take a correspondence course; and if he enrolls with the C.R.E.I., which has the Army's approval, he will have to pay only £1, the rest (about £45) being met by the Army. Incidentally, his progress during the course is notified to the School so that, in fact, the C.R.E.I. course is a continuation of his Corps training. After two or three years in the field he returns to the School for up to 23 weeks for an "upgrading" course during which he will specialize in more advanced equipment in his particular branch—telecommunications; radar and guided weapons; or servos and computing. He then goes into the field again for from two to five years. During this period he will be advised to take another C.R.E.I. correspondence course on the same conditions. He will by then be a sergeant and may return to the School for an eighteen-month artificer's course at H.N.C. level and is the culmination of 5½ years' training at the School. The total cost of training an artificer is said to be about £7,000.

The School is not only concerned with training N.C.O.s and other ranks. It has a number of specialized courses for officers (not necessarily R.E.M.E. officers) including a 42-week Officer's Long Electronic Engineering Course at postgraduate level.

It is impossible to deal adequately within the scope of a short article

with the training given and the influence wielded by the School. Mention must however be made of some of the specially devised training aids used.

To demonstrate basic electronic circuits a console, comprising "breadboard" circuits (with plug-in components), large-scale meters, and a four-beam teaching oscilloscope, is used. Students each have small "breadboard" circuits on which to carry out their own experiments with plug-in components of different values. With this console over sixty different circuits can be taught.

The circuit assembly board illustrated on the previous page comprises a series of sockets wired

in squares of four to facilitate the plugging in of specially mounted components.

At present, commercially produced fault-finding question sheets are used on which the student records each step in his fault diagnosis. The School is however in the process of developing its own electro-mechanical device. What is described as a systems assembly board has been developed which, with plug-in circuit modules, enables systems to be built up for the instruction of artificers.

Among the outside professional interests fostered by the Commandant and his staff is the Students' Branch of the Radar and Electronics Association introduced at the School and it is noteworthy that two of the students recently received the Association's 1st and 3rd prizes for the best apprentices of the year. The School also sponsors a branch of the I.E.E.

One last word. Although the School is run as a technical college and there are no such things as "reveille" or "lights out" the staff does not lose sight of the fact that they are training *soldier* technicians. The men leave the school as fully trained soldiers.

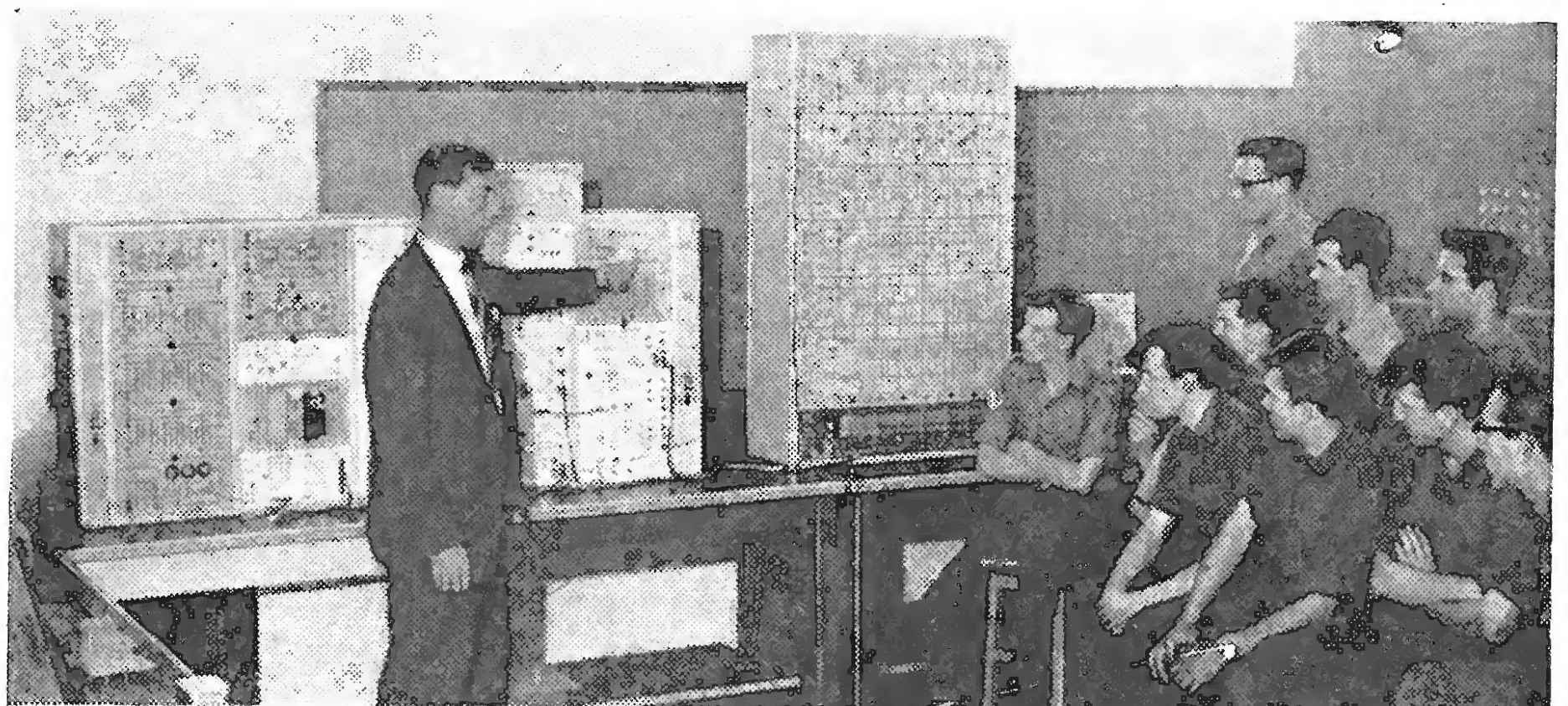

ADDIT (apparatus for demonstrating digital techniques) designed by the staff being used to illustrate basic computing techniques.

## SECOND INTERNATIONAL EXHIBITION OF INDUSTRIAL ELECTRONICS IN BASLE

# INEL 65

**H**OWEVER much Europeans may deplore it, electronic technology throughout the Western world is dominated by the U.S.A. That this is true of the industrial side as well as other branches of electronics was very evident from the 2nd International Exhibition of Industrial Electronics, INEL 65, held in the permanent buildings of the Swiss Industries Fair, Basle, early in September. Not only was there a separate, self-contained section of forty or more American firms—many of them small specialist manufacturers not well known in Europe—but the main body of the exhibition was heavily loaded with American-made or -designed products, shown by European subsidiaries of U.S. companies, by European agents and by European manufacturers with licensing arrangements. Attempting to counterbalance this weight of American technology were the few big Continental firms like Philips, Ericsson and Oerlikon and two national groups of exhibitors, French and British respectively. The contribution of the smaller European firms to this counterbalancing was more in the volume than the technical significance of their exhibits. In fact, if it were not for the presence of American technology INEL would probably have a hard time justifying its existence.

The greater part of the exhibits consisted of standard electronic components, units and measuring instruments (mostly for electrical variables). Of the genuinely *industrial* electronic systems and equipments on show the majority were concerned with the processing of information—a field in which electronics has shown outstanding versatility and has tremendous potential. One example was an equipment shown by the Reliance Electric and Engineering Co. (U.S.A.) for digitally measuring and displaying the linear speed of the paper web in different sections of a papermaking machine and also the “draw,” or differential speed, between sections. Speeds and draws are critical in manufacturing papers of particular characteristics, and accurate digital measurement greatly assists the operators in setting up the machine conditions required for a particular type of paper with minimum wastage of material. It is this saving of material which justifies the cost of the electronic equipment.

The measuring transducers are rotary pulse generators driven through gearing from the machine rolls, and arranged so that, for example, one pulse is generated for every one foot of linear paper movement through the rolls. The timebase needed for speed measurement is provided by an accurate crystal oscillator and an electronic counter. This counter gates the output of a selected rotary pulse generator during intervals of one minute, so that if the pulse generator produces 1,000 pulses in one such interval the linear paper speed is 1,000 ft/minute. The gated pulses can thus be counted and directly displayed on a numerical in-line indicator as feet per minute. Differential speeds, absolute or per cent, are measured by a similar technique using two pulse generator inputs and a differential (reversible) counter.

Compensation for changes in roll diameter due to

wear, and for gear ratio and other machine errors, is performed electronically by pre-setting the timebase system on a plug-board programming panel. Thus, if the diameter of a roll were reduced by wear the rotary pulse generator driven by it would produce pulses at a frequency slightly greater than 1 per linear foot, and this would be compensated by shortening the timebase so that it gated the pulses over an interval of slightly less than a minute. The whole equipment uses solid-state digital circuitry mounted in a series of plug-in units, which allow flexibility of application.

Another equipment using a plug-board programme and semiconductor circuitry was an automatic electric welding machine shown by the Swiss firm, R. U. Schild & Co. The purpose of this machine is to eliminate the majority of the control adjustments which normally have

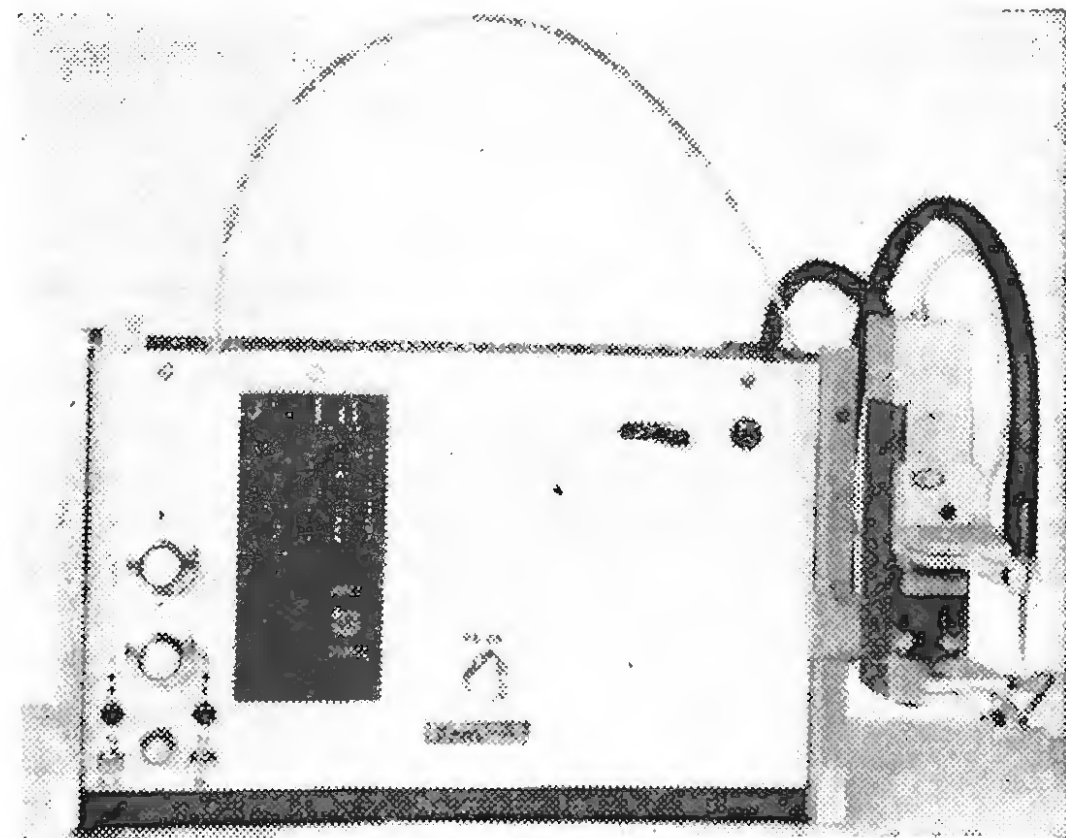

Automatic electric welding machine with plug-board programming system (R. U. Schild).

to be made by the operator during a large production welding sequence. The pre-set programme allows a sequence of 12 different welding operations to be performed automatically, and all the operator has to do is to present to the machine the parts to be welded in the correct order. For each operation in the sequence the plug-board allows a choice of four electric welding “powers” (watts/sec) and two welding “pressures” (kg) to be pre-set, and each of these variables can be continuously adjusted in advance. The plug-board programme is scanned electronically by semiconductor circuitry and this scanning allows the sequence to be stopped at will, or to skip several operations, or to repeat a particular operation as many times as may be required. Maximum welding speed with the electropneumatically operated welding head is 180 spots per minute (with a power of 100 watts/sec).

Automatic data processing equipments for accounting, production control and other recording purposes are now being attached to a variety of machines, but probably the most unexpected application to be seen at the exhibition was a system making possible a “help-yourself” petrol

pump. The customer draws as much petrol as required, with the aid of an electronic numerical indicator of volumetric flow mounted in the pump, and the amount drawn and the price is automatically recorded on an adding-listing machine in a nearby office. The advantage of the system is that it allows a variety of accounting procedures to be performed automatically (e.g., totaling all charges made to a particular customer), and the equipment contains various electronic facilities such as flip-flop binary data stores allowing several pumps connected to it to be used at the same time. Developed by the Swedish firm RETAB, the equipment uses semiconductor circuits throughout and a large proportion of these are Texas Instruments integrated circuits (adopted, according to the exhibitors, Fabrimex, for reasons of lower cost and greater reliability). The mechanical flow metering part of the equipment is orthodox, but, of course, the flow measurement is converted into electrical form by a digital transducer.

A high degree of automatization, permitting rapid operation, is a feature of the Beckman Instruments liquid scintillation spectrometer—an instrument for counting beta particles from radioactive isotopes in which the sample is immersed in a liquid scintillating medium. A built-in computer calculates the counts/minute rate every 1.2 seconds, allowing continuous digital presentation of count rate during the counting cycle. The rate is computed for both pre-set time intervals and pre-set count intervals, and there is also an automatic correction for background radiation in which the background count rate is subtracted from the overall count rate. Computing is also involved in an automatic calibration system for the instrument, using an external radiation standard.

Apart from the specialized systems mentioned above, several general-purpose information processing equipments were to be seen. A new approach to the problem of random-access storage of large volumes of data was demonstrated by the Potter Instrument Company, U.S.A. Magnetic tape is the most economical medium for storing large quantities of data but it does not allow convenient random access because of the serial nature of the information on the tape. On the other hand, systems of discrete elements such as ferrite core matrices are very suitable for random access but are too expensive for storing information in quantities of millions of bits. The Potter equipment effects a compromise by using a number of short loops of tape, each loop carrying a multiplicity of tracks, which are driven past read/write heads,

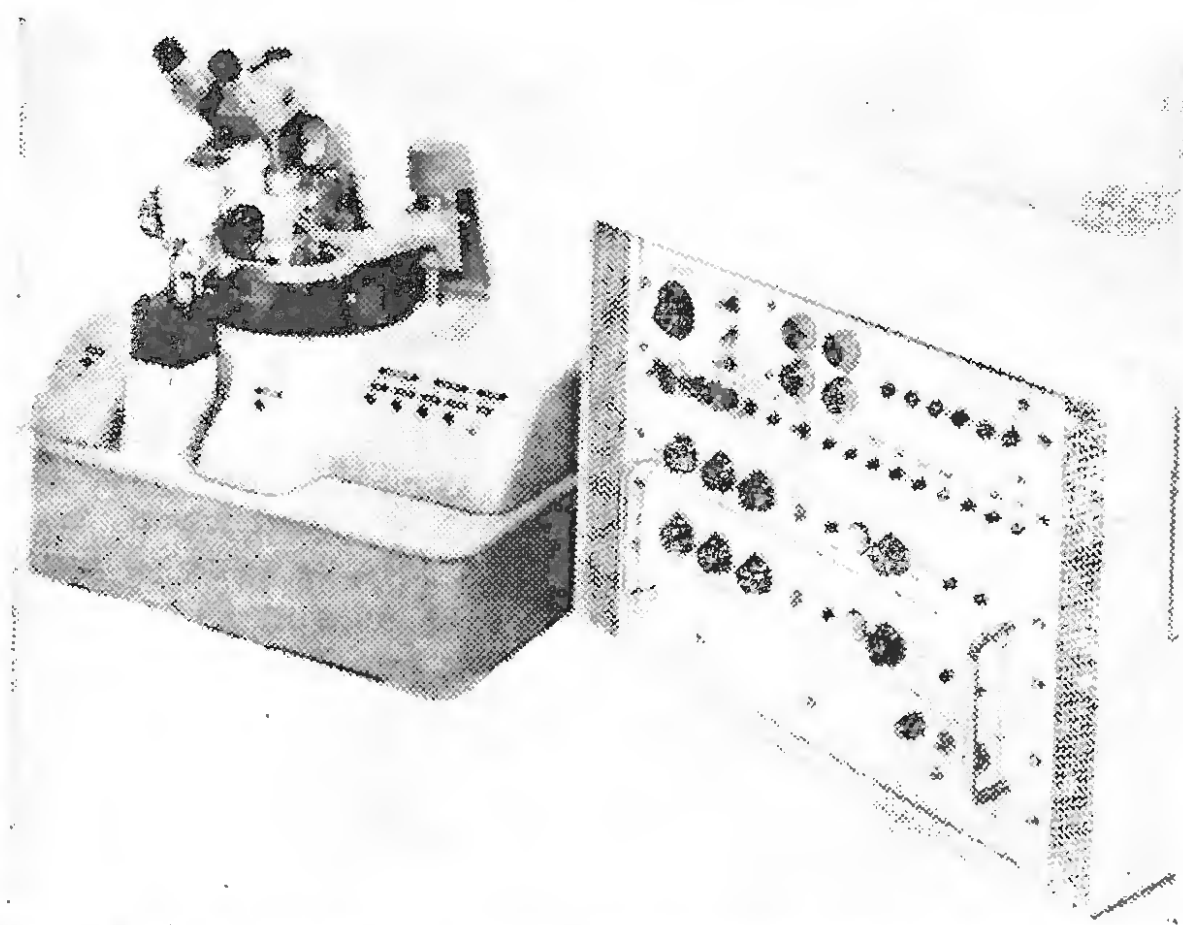

Shown by Electroglas, this automatic integrated-circuit tester will handle up to 2,000 devices per hour.

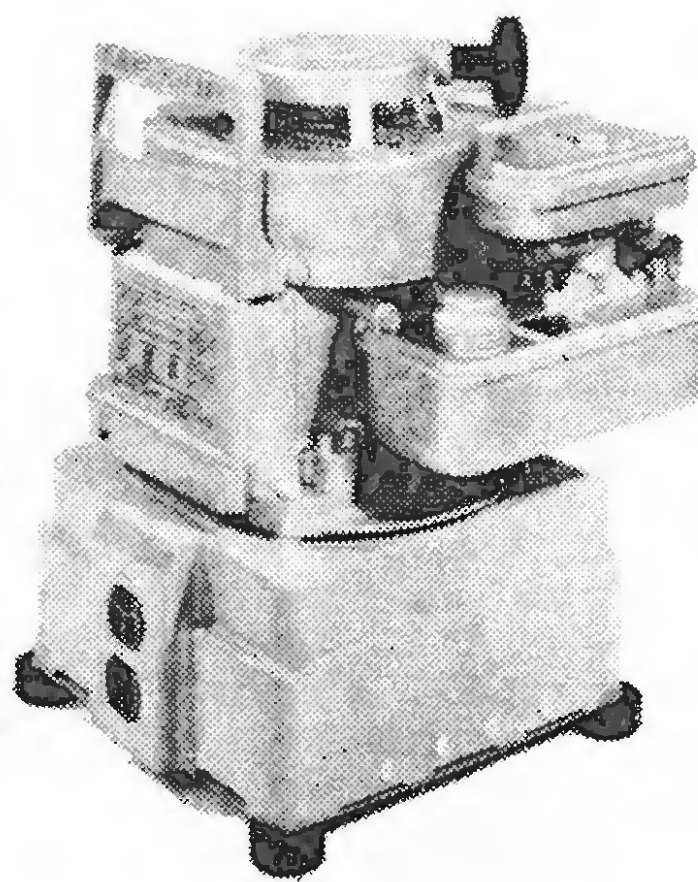

This portable petrol-driven electric power generator shown by McCulloch Mite-E-Lite Inc. uses a rotating permanent magnet to overcome brush problems and increase efficiency. Weighing 55 lb, it produces 650 watts.

using air bearings. A group of eight such loops forms a tape cartridge, a complete unit capable of storing 25.1 million bits which can be loaded into and withdrawn from the main machine. It is claimed that the system is cheaper to buy and to operate than comparable random-access stores using magnetic discs, and a particular advantage over this disc type of machine is said to be that the Potter equipment can check-read data immediately after it is written on the tape, thereby giving faster operation in many storage operations.

## Computing equipment

In the field of electronic computing, the French firm Electronique Marcel Dassault were demonstrating a neat desk-top calculating machine for office and laboratory work, using semiconductor binary digital circuits, ferrite-core storage of programmes and immediate print-out of calculation steps and results on a narrow paper tape. Numbers and programme instructions are entered by the operation of press-buttons. Designed principally for industrial real-time control operations are the Honeywell H20 and the Litton L-3040 stored-programme digital computers. The last-mentioned is particularly interesting because it is constructed entirely by integrated circuit techniques. Working in the parallel mode with a 32-bit word length, it has a magnetic core store, expandable in 4096-word modules from 4096 to 32,768 words, and a 1.6  $\mu$ sec storage read/write cycle. The circuitry takes the form of NAND logic gates interconnected by laminated boards containing multiple layers of conductors. Such a computer containing an 8,192-word store weighs about 38 pounds, occupies a volume of 0.28 cu ft and consumes 110 watts of power.

In the field of measurement and instrumentation the scene tended to be dominated by test and measuring equipment for electrical variables—multimeters, oscilloscopes and the like. One of the more unusual instruments in this category was a Rohde & Schwarz (German) reflectometer, having the useful features of being direct-reading (on a pointer indicator), working over a broad frequency band without tuning (30 to 1,000 Mc/s) and independently of the input signal generator level, and being able to measure, at the same time, low attenuations in the range 0.05 dB to 5 dB. Reflection coefficients of networks, aeriels, transmission lines, etc., can be measured over the range 0.5% to 100%.

Some of the electrical measuring instruments, how-

ever, could also be used for measurement of other physical variables, such as the sensitive Keithly nanovoltmeter (10 nV d.c. full scale) intended for use with thermocouples and other low-impedance transducers producing small voltages. This American instrument has a resolution of 1 nV, and is claimed to have a stability of 10 nV per 24 hours. Specifically designed for temperature measurement was a Hewlett Packard instrument based on the temperature sensitivity of a quartz crystal in an oscillatory circuit. Changes of temperature affecting the quartz crystal probe vary the oscillator frequency, and this is used to give a digital indication of temperature. The instrument will work between  $-40^{\circ}\text{C}$  and  $+230^{\circ}\text{C}$  and will resolve temperature changes of  $0.0001^{\circ}\text{C}$ .

Oscilloscopes of particular interest included a new Tektronix instrument, Type 549, combining high speed (5 mm/ $\mu\text{sec}$ ) with trace storage; a plug-in unit for the Hewlett Packard Type 175A providing a recording on a paper chart of any waveform displayed (a sampling technique being used); and a Ferisol oscilloscope of extremely wide bandwidth (0 to 1 Gc/s) capable of displaying waveforms with risetimes as small as 0.15 nanosecond. In the last-mentioned instrument the wide bandwidth is obtained by not using a y amplifier but applying the signal directly to the vertical deflection plates. This, of course, means that the sensitivity is limited (10 V/cm), but it is claimed that the fine spot of the c.r.t. allows trace deflections of less than a millimetre to be seen.

Among the many electronic components on show, a notable exhibit on the British group stand was a display of magnetic shields suitable for instruments, relays, watches, cathode-ray tubes, etc.—but manufactured, unusually, by the technique of electroforming. This is an entirely new process for magnetic materials, developed by Plessey Radar on the basis of their experience in the electroforming of copper and nickel microwave components. The advantage of the technique is that shields

of high-permeability alloys (similar to well-known proprietary materials) can be fabricated as one-piece shells which are free from the mechanical joints and large internal stresses that normally cause a deterioration of performance. The electroformed shields can be deposited directly on glass devices such as cathode-ray tubes, or made as separate components to any desired shape. Electrical shielding is provided as well, of course, by the conducting property of the material.

Another unusual type of component, in the field of machine control, was an electrohydraulic impulse motor, providing a high-power rotary drive controllable in steps by low-power electrical impulses. Stepped rotary motion can, of course, be obtained from conventional electric stepping motors, but these suffer from poor response speed if high output power is required (because of their mechanical inertia). In the device on show, made by Fujitsu of Japan, hydraulic drive techniques overcome the inertia problem, and the hydraulic power is controlled through a valve system by a small and light electric torque motor energized by low-power electrical impulses. The motor could be used for digital position control on machine tools or other equipment, and, because of the precise angular positioning inherent in the stepping action, it offers the possibility of obtaining accurate control without the need for a closed-loop system.

A useful, simple, non-contacting transducer for timing, position indication or speed measurement of moving mechanical parts was an electromagnetic pick-up made by Electro Products Laboratories of Chicago. It is basically a small pick-up coil combined with a permanent magnet. When the steady magnetic field is disturbed by a ferrous object—say the teeth of a rotating gear wheel—the coil generates an a.c. voltage. Various sizes are available, but one of the latest is a miniature unit measuring  $\frac{3}{8}$  in diam. by  $\frac{1}{2}$  in long, capable of giving output signals of up to 3 V.

## OCTOBER MEETINGS

*Tickets are required for some meetings : readers are advised, therefore, to communicate with the secretary of the society concerned*

### LONDON

1st. Television Soc.—“Present status of colour television” by C. J. Hirsch of R.C.A. at 7.0 at I.T.A., 70 Brompton Rd., S.W.3.

4th. I.E.E.—“Infra-red devices—propagation, generation and reception” by G. Phillips at 5.30 at Savoy Pl., W.C.2.

6th. I.E.E.—Discussion on “Filling gaps in v.h.f./u.h.f. service areas” at 5.30 at Savoy Pl., W.C.2.

6th. I.E.R.E.—“SECAR—a modern s.s.r. ground interrogator and decoding equipment” by H. W. Cole at 6.0 at 9 Bedford Sq., W.C.1.

6th. B.K.S.T.S.—“A transistorised capacitor microphone” by M. L. Gayford at 7.30 at the Central Office of Information, Hercules Rd., S.E.1.

12th. Radar & Electronics Assoc.—“Transmitting aerial systems for television broadcasting on u.h.f.” by G. C. Platts at 7.0 at the Royal Society of Arts, John Adam St., W.C.2.

13th. I.E.E.—Discussion on “What is group delay” at 5.30 at Savoy Pl., W.C.2.

13th. I.E.R.E.—“Signal processing using optical techniques” by Dr. D. C. Cooper at 6.0 at 9 Bedford Sq., W.C.1.

13th. B.K.S.T.S.—“Photographic film emulsions and magnetic coatings” by H. O. Dickinson and H. J. Hutchings at 7.30 at Central Office of Information, Hercules Rd., S.E.1.

14th. I.E.E.—“Long wavelength laser generation” by L. E. S. Mathias at 5.30 at Savoy Pl., W.C.2.

15th. Television Soc.—“Problems connected with the use of colour film for colour television” by Dr. F. P. Gloyns at 7.0 at I.T.A., 70 Brompton Rd., S.W.3.

19th. Soc. of Relay Engrs.—“Testing methods and equipment applicable to v.h.f. and h.f. wired television systems” by W. B. Smith at 2.30 at the I.E.E., Savoy Pl., W.C.2.

20th. I.E.E.—Address by Prof. A. L. Cullen, chairman of the Electronics Division at 5.30 at Savoy Pl., W.C.2.

20th. Soc. Environmental Engrs.—“Radio frequency interference control” by D. J. Lewis & A.S. Evans at 6.0 at Imperial Col-

lege, Mechanical Eng'g. Dept., Exhibition Rd., S.W.7.

20th. I.E.R.E.—Discussion on “Computer/instrument interfaces” at 6.0 at London School of Hygiene and Tropical Medicine, Keppel St., W.C.1.

21st. I.E.E.—Discussion on “Instrument scale graduation” at 5.30 at Savoy Pl., W.C.2.

25th. I.E.E. & I.E.R.E.—“Opto-electronics” by Professor W. J. Poplebaum at 5.30 at Savoy Pl., W.C.2.

27th. S.E.R.T.—“Video tape recording equipment” at 6.0 at Royal Soc. of Arts, John Adam St., W.C.2.

27th. B.K.S.T.S.—“The design of loudspeakers for low frequency reproduction” by R. E. Cooke at 7.30 at the Central Office of Information, Hercules Rd., S.E.1.

28th. I.E.E., Television Soc. & I.E.R.E.—“PAL television system” by Dr. W. Bruch at 6.0 at Savoy Pl., W.C.2.

29th. Television Soc.—“Amateur-professionals or professional amateurs?—a new look at the British Amateur Television Club” at 7.0 at I.T.A., 70 Brompton Rd., S.W.3.

## OCTOBER MEETINGS *Continued*

### BATH

28th. I.E.R.E. & I.E.E.—“Infra-red technology and applications” by V. Roberts at 7.0 at Bath Technical College, James Street West.

### BIRMINGHAM

25th. I.E.E.—“Safety or disaster—the reliability of electronic equipment” by J. C. Cluley at 6.30 at M.E.B., Summer Lane.

28th. I.E.R.E.—“The early history of radio” by G. R. M. Garratt at 6.30 at Department of Electronic and Electrical Engineering, University of Birmingham.

### BRADFORD

26th. I.E.E.—“Television standards conversion by electronic methods” by E. R. Rout at 6.30 at Institute of Advanced Technology.

### BRIGHTON

27th. I.E.E.—“Automation in computer design” by D. G. Jacobs at 6.30 at College of Technology, Moulsecoomb.

### BRISTOL

7th. S.E.R.T.—“R.F. transmission lines” by B. Garland at 7.45 at Hawthorns Hotel, 8.

20th. I.E.R.E.—“Laser technology and applications” by J. MacDowall at 7.0 at University Engineering Laboratories, University Walk, Clifton.

### CAMBRIDGE

14th. I.E.E.—“Chance and the communications engineer” by G. R. Nicoll at 8.0 at Engineering Laboratories, Trumpington St.

### CARDIFF

4th. I.E.E.—“Field effect transistors: another minor revolution in transistor practice” by W. Fishwick at 6.0 at South Wales Institute of Engineers.

13th. I.E.R.E.—“Phase shift networks using field effect transistors” by W. Gosling at 6.30 at Welsh College of Advanced Technology.

15th. Television Soc.—“A 90° colour tube.” by P. L. Mothersole at 7.30 at the Royal Hotel.

### CATTERICK

13th. I.E.E.—Discussion “The communication of knowledge” at 6.30 at School of Signals.

### CHRISTCHURCH

20th. I.E.E.—“The U.K.3” by H. J. Sketch at 6.30 at King’s Arms Hotel.

### COLCHESTER

8th. Instn. Prod. Engrs.—“An introduction to electronic computers” by P. Ruglys at 7.30 at N.E. Essex Technical College, Sheepen Rd.

26th. I.E.R.E.—“Some examples of simulation and computer techniques in electronic engineering” by N. A. Huttly at 7.30 at North East Essex Technical College, Sheepen Rd.

### EDINBURGH

6th. I.E.R.E.—“Input spectrum and the ability to optimize” by Dr. I. Cochrane at 7.0 at Department of Natural Philosophy, The University, Drummond St.

28th. I.E.R.E. & I.E.E.—“Electronics in medicine—frustrations and fulfilment” by Dr. J. M. A. Lenihan at 6.0 at Carlton Hotel, North Bridge.

### FARNBOROUGH

14th. I.E.R.E.—“Fuel cells, a customer’s viewpoint” by Dr. W. R. S. Davidson at 7.0 at Farnborough Technical College.

### GLASGOW

7th. I.E.R.E.—“Input spectrum and the ability to optimize” by Dr. I. Cochrane at 7.0 at Institute of Engineers and Shipbuilders, 39 Elmbank Crescent.

### GUILDFORD

12th. I.E.E.—“Computers” by F. J. M. Laver at 7.30 at Central Electricity Generating Board.

### HORNCHURCH

12th. I.E.R.E.—“Satellite communications” by W. J. Bray at 7.0 at College of Further Education, 42 Ardleigh Green Rd.

### LEEDS

6th. S.E.R.T.—“The manufacture of transistors” by A. Lingard at 7.30 at Branch College of Engineering, Cockridge St., 2.

### LIVERPOOL

11th. I.E.E.—“Static electronic protection?” by J. B. Patrickson at 6.30 at the Royal Institution, Colquitt St.

18th. I.E.E.—“Trends in telecommunications switching” by L. J. Murray at 6.30 at Royal Institution, Colquitt St.

20th. I.E.R.E.—“Colour television” by Professor G. N. Patchett at 6.30 at Walker Art Gallery.

26th. I.E.E.—“Blue print of a professional engineer” by J. B. Lancaster at 6.30 at the Royal Institution, Colquitt St.

### MANCHESTER

6th. S.E.R.T.—“Exploitation of the transistor” by R. A. L. Warrington at 7.30 at Engineers’ Club, Albert Square.

19th. Instn. Prod. Engrs.—“The computer as a tool for production control” by G. H. Smethurst at 7.15 at Renold Bldg., Manchester College of Science & Technology, Sackville St.

21st. I.E.R.E.—“PAL colour television” by M. Cox at 7.0 at Renold Building, College of Science and Technology, Sackville St.

### NEWCASTLE-ON-TYNE

6th. S.E.R.T.—“The introduction of 625-line television transmissions at u.h.f.” by M. T. Pacey at 7.15 at Charles Trevelyan Tech. College, Maple Terrace, 4.

### NEWPORT, I.O.W.

1st. I.E.E.—“Computers” by R. A. Laws at 6.30 at I.O.W. Technical College.

### NOTTINGHAM

5th. I.E.E.—“Magnetostriction” by Dr. W. Alexander at 6.30 at Main Lecture Theatre, T.I. Building, University.

12th. I.E.E.—“Hall effect devices” by Dr. J. P. Newsome at 6.30 at First Year Applied Science Block, University.

### NORWICH

5th. I.E.E.—“Instrumentation of a rocket testing site” by J. W. Dalgleish at 7.30 at Assembly House.

### PETERBOROUGH

8th. Instn. Prod. Engrs.—“Television in industry” by H. O. E. Carter at 7.30 at

Peterborough Generating Station, Albert Place.

20th. I.E.E.—“Electro levitation” by E. R. Laithwaite at 6.0 at Angel Hotel.

### PORTSMOUTH

6th. I.E.E.—“The microcircuit revolution” by C. E. Tate at 6.30 at Telephone Exchange, Park Road.

20th. I.E.E.—“Semiconductor operational amplifiers” by R. C. Foss at 6.30 at College of Technology, Anglesea Road.

### READING

19th. I.E.R.E.—“Research in electronic instrumentation at the University of Reading” by Dr. E. A. Faulkner at 7.15 at J. J. Thomson Physical Laboratory, University of Reading.

### SALFORD

18th. I.E.E.—“The place of the computer in engineering education” by E. Kerr at 6.15 at Royal College of Advanced Technology.

### SOUTHAMPTON

12th. I.E.E.—“The history of computers” by D. J. Truslove at 6.30 at The Lanchester Theatre, University.

13th. S.E.R.T.—“A review of fifty years of electronics” by Dr. K. E. Everett at 7.30 at College of Technology, East Park Terrace.

26th. I.E.R.E. & R.Ae.S.—“Loudness of sonic booms and similar sounds” by Professor E. E. Zepler at 6.30 at Lanchester Theatre, University of Southampton.

### STOKE-ON-TRENT

12th. I.E.R.E.—“Computers — present and future” by R. Woolf at 7.0 at North Staffs College of Technology, College Rd.

### SWANSEA

21st. I.E.E.—“Field effect transistors: another minor revolution in transistor practice” by W. Fishwick at 6.0 at Engineering Department University College.

### WHITBY

5th. I.E.E.—“Recent developments in multiple access computer operation” by M. V. Wilkes at 7.0 at Botham’s Cafe, Skinner St.

## LATE SEPTEMBER MEETINGS

### LONDON

29th. I.E.R.E. & I.E.E.—“Airborne computers” conference at 10.30 at the London School of Hygiene and Tropical Medicine, Keppel St., W.C.1.

29th. I.E.R.E. & I.E.E.—“Treatment of experimental animal and human malignant tumours by laser radiation” by Dr. P. E. McGuff at 6.0 at 9 Bedford Sq., W.C.1.

30th. S.E.R.T.—“The use of oscilloscopes in maintenance” by R. W. Watson at 6.30 at Royal Soc. of Arts, John Adam St., W.C.2.

30th. Television Soc.—“An introduction to waveform testing methods in television” by I. F. Macdiarmid at 7.0 at the I.T.A., 70 Brompton Rd., S.W.3.

### MANCHESTER

30th. I.E.R.E.—“Radar” by N. P. Robinson at 7.0 at Renold Bldg., Manchester College of Science and Technology, Sackville St.

# Electronic Laboratory Instrument Practice

## 10.—MEASUREMENT OF FREQUENCY

By T. D. TOWERS, \*M.B.E., A.M.I.E.E., A.M.I.E.R.E.

**I**N a run-of-the-mill electronics laboratory, frequency is one of the things that you have the least occasion to measure and, ironically, it is the one that you can measure with the most accuracy. Almost around the clock, even the most ill-equipped establishment can pick up, for nothing, world frequency standard transmissions of an absolute accuracy of the order of 1 in  $10^8$ . Not only that; simple frequency comparison techniques exist which lose little of this accuracy. This means that any laboratory can with ease check its frequency measuring equipment to not worse than 1 in  $10^7$  (or one part in ten million).

### Basic considerations of frequency measurement

Now, academically that may be very interesting information, but it does not really help the poor lab. worker when he is first faced with the problem of arriving at the frequency of an unknown signal. His approach must be primarily practical, and it must be done in four stages. First, he must possess himself of a suitable measuring instrument; secondly, he must find some standard against which to check it; thirdly, he must calibrate his instrument against the standard; and lastly, he can then measure his unknown frequency.

As to the choice of measuring instrument, there are more than a few different types, but they fall into the main categories: (a) wavemeters; (b) grid-dip meters; (c) heterodyne meters; (d) capacitor-discharge meters; (e) frequency bridges; (f) calibrated oscilloscopes; (g) digital counter-type meters; and (h) miscellaneous instruments. We shall look at these various types individually later, but first it is well to consider what standards are available in the ordinary laboratory for calibrating them and how to carry out such calibration.

### Frequency standards

Frequency standards available to a laboratory fall into three main groups: (a) standard-frequency radio transmissions; (b) laboratory calibrated signal sources; and (c) calibrated frequency measuring instruments.

*Standard-frequency radio transmissions* are within the reach of anyone who owns a domestic radio receiver capable of receiving the B.B.C. transmitters at Droitwich on 200 kc/s (1,500 metres). The deviations of the Droitwich carrier signal are maintained within the limits of  $\pm 5$  parts in  $10^9$  of the nominal 200 kc/s frequency. The nominal frequency is defined on the basis of 200,000 cycles in 1 second of Ephemeris Time (E.T.), this 1 second being realized in practice as 9,192,631,770 cycles of the caesium resonance frequency at zero field. And not only does Droitwich provide you with a highly accurate 200 kc/s carrier signal, but also its transmissions

are preceded by a highly accurate 1,000 c/s tuning signal.

With your domestic radio, again, you can use certain medium-frequency broadcasting stations to provide a selection of other carrier frequencies between 150 and 550 kc/s accurate to better than 1 in  $10^7$ .

Furthermore, if you have a short-wave or communications receiver, you can pick up the British G.P.O. special service of frequency-standard transmissions from MSF (Rugby) radiated simultaneously on 2.5, 5 and 10 Mc/s continuously for 24 hours a day (except for a five minute interruption from minute 15 to minute 20 in each hour).

If, on the other hand, you should happen to have a suitable special l.f. receiver, you can use transmissions on 60 kc/s from MSF (Rugby) and 16 kc/s from GBR (Rugby) as standards. The 60 kc/s transmitter works one hour each day from 14.29 to 15.30 GMT, and the 16 kc/s transmission generally operates for about 22 hours a day (with a maintenance period from 13.00 to 15.00 GMT). Incidentally, when GBR (Rugby) on 16 kc/s is inoperative, GBZ (Criggon) on 19.6 kc/s is available.

Standard-frequency transmissions are also radiated in a continuous 24-hour service from the American National Bureau of Standards' stations WWV, near Washington, D.C., and WWVH, in Hawaii. These radiate carrier frequencies accurate to at least  $\pm 1$  in  $10^8$  on 2.5, 5, 10, 15, 20 and 25 Mc/s.

The modulations on these standard-frequency transmissions change from time to time, but on one or other of them modulations of 1 c/s, 440 c/s, 1,000 c/s and 4,000 c/s are available, which could be used for calibrating local audio frequency standards. However, by using accepted methods of successive frequency division, you can obtain spot frequencies in the audio range to the same order of accuracy as the r.f. carrier standard-frequency transmissions, and this subdivision of r.f. is the more usual method for high accuracy audio frequency calibration.

Conversely, when it comes to frequencies in the v.h.f./u.h.f. bands you can use techniques of frequency multiplication to extend the r.f. transmission frequency standards upwards as required.

*Signal Generator Standards.*—Active signal sources in the laboratory are the second main group of frequency calibration standards. For example, a good-quality stable signal generator, calibrated against standard-frequency transmissions, makes a very useful transfer standard usable when no suitable transmission is available. Another approach is to make up a quartz-crystal (or high-stability LC) oscillator specially for calibration purposes. In these days of the transistor, it will not be found very difficult to make up a simple basic oscillator of this type. Fig. 70 gives a typical circuit for a battery-

\*Newmarket Transistors Ltd.

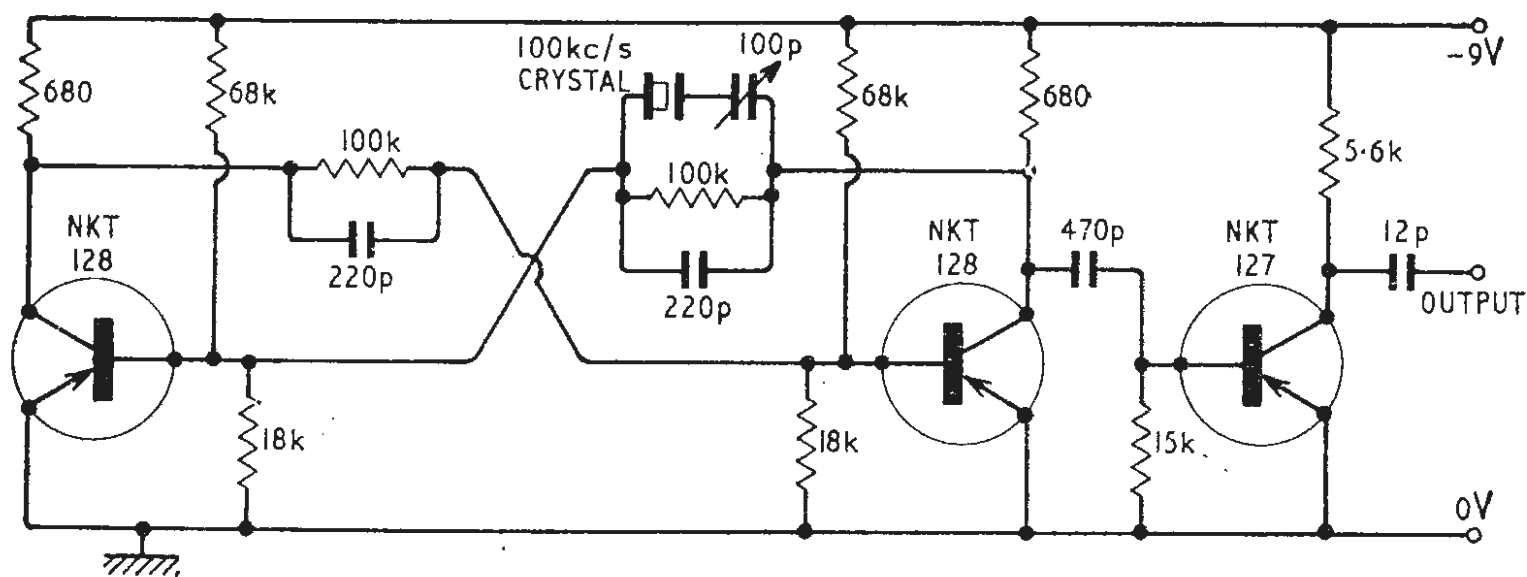

Fig. 70. Circuit for general-purpose 100 kc/s quartz crystal calibration standard oscillator.

operated 100 kc/s crystal oscillator which provides locked harmonics off to many tens of megacycles. The 100 pF variable capacitor in series with the series-mode 100 kc/s quartz crystal is used to adjust the calibration of the instrument against a standard-frequency transmission.

Another "signal-generator" type of laboratory frequency-reference sometimes very useful is a "physical" source such as tuning fork or a vibrating reed. It is surprising what accuracy of frequency can be obtained with even such simple sources as these.

**Frequency-meter Standards.** — Standard-frequency transmissions and standard oscillators apart, some laboratories use high-accuracy frequency-measuring instruments themselves as reference standards. Wavemeters and grid-dip meters are typical of this class.

Before we leave the question of standards, however, it is well for the reader to get some idea of the sort of accuracy one can expect from the various types. Typically these are: LC-tuned circuits=1 in  $10^4$ , tuning fork=1 in  $10^5$ , well-designed quartz-crystal=1 in  $10^6$ , Ephemeral Time standard=1 in  $10^9$ , and Caesium resonance=1 in  $10^{11}$ .

At this point, also, a warning on the accuracy of mains frequency (sometimes used for reference) is not out of place. Generally the frequency lies within  $\pm 0.5$  cycle of the nominal 50 c/s frequency, thus implying an accuracy of only 1 in  $10^2$  (1%). But, under abnormal conditions, e.g. load shedding, the frequency may vary from as low as 47.5 c/s to as high as 51.5 c/s, i.e. -5% to +3%. Of course, the *mean* frequency over a long period is kept very accurately to 50 c/s so that, although synchronized electric clocks may go fast or slow over short periods, they eventually return very near to the correct time.

### Calibrating instruments against standards

Having obtained a suitable measuring instrument and standard, the next step is to check one against the other. For this you need some sort of frequency-coincidence detector arrangement. Such detectors may be of three types:—(a) acoustic (b) meter and (c) visual.

**Acoustic Frequency-coincidence Detectors.**—Acoustic methods can be used in several ways. The first is the simple zero-beat method in which two signals being compared are mixed and adjusted until the audible beat between them falls to zero. This is usually satisfactory when two radio frequencies are being compared, but, because of the uncertainty of hearing below about 20 c/s, it is not entirely satisfactory when two audio frequencies are being compared. In such a case the so-called "double-beat" or "slow-beat" method is used. In this, a third (different) frequency is set up and the standard is adjusted against this to give an audible beat frequency. The unknown signal is then tuned to beat also with this third frequency, and adjusted until the slowest beat is achieved between the two audible beat frequencies. This double-beat method is capable of much greater accuracy than the simple zero-beat one, and differences of 1 c/s can be measured.

Another example of the use of acoustics to provide a frequency-coincidence detector is in the null-detector headphones of a frequency bridge (to be described later). Here the bridge controls are adjusted until the "resonance" frequency of the bridge coincides with the frequency being measured, the indication of synchronism being a minimum signal in the headphones.

**Meter Frequency-coincidence Detector.**—Where the headphones of a frequency bridge are replaced by a meter-presentation null detector, we have one example of the next main class of coincidence detectors, i.e. meter types. Another example is where a meter circuit is used with a pointer displacement proportional to the beat frequency. A final example is the meter presentation of frequency-coincidence exemplified in the numerical display on a digital counter-type frequency meter when it is used to monitor the beat frequency while bringing two signals into synchronism.

**Visual Frequency-coincidence Detectors.**—Apart from acoustic and meter methods, visual displays of frequency

Fig. 71. A simple frequency-coincidence detector circuit.

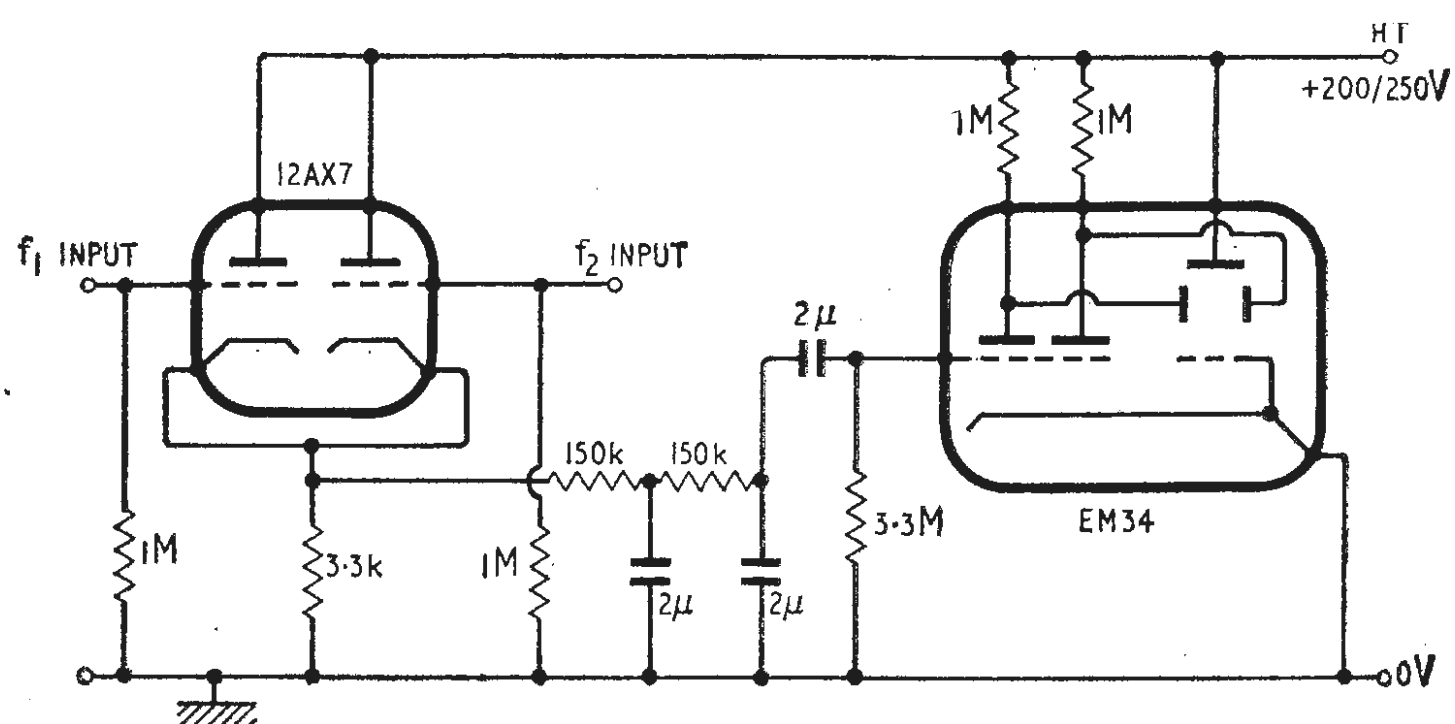



coincidence are widely used. The commonest example of this is the use of an oscilloscope where the two signals under test are fed to the x and y amplifiers, and one is adjusted until the scope trace becomes stationary. When this happens, one frequency (or one of its harmonics) is in synchronism with the other. Stationary-trace scope comparison of frequencies is really only satisfactory with audio and low radio frequencies. With higher frequencies, it will be found impracticable to hold the trace stationary.

However, if the scope is run on its own time-base, and the two high frequency signals to be compared are fed together in the y amplifier input, it is possible to see visually the coincidence of the frequencies as the envelope of the trace becomes modulated at the beat frequency when synchronism is approached.

Another visual method is the use of a "magic-eye" tuning indicator. There are many possible arrangements. One of these (due to H. V. Beck, p.405 of the October 1951, *Electronic Engineering*) is given in Fig. 71. When  $f_1$  is nearly equal to  $f_2$  in this circuit, the indicator will be found to flicker at a frequency equal to the difference, and a frequency difference of 0.05 c/s is easily distinguished.

One final rather "off-beat" example of the use of a visual frequency-coincidence indicator that may be met with is the "reed" meter sometimes used to check mains frequency. In this, a set of metal reeds tuned at intervals around 50 c/s (the reeds being electrically coil-driven) are arranged to be visible. When the signal to be tested is applied to the driver coil, the reed with a resonant frequency closest to the input frequency oscillates more violently than its neighbours and gives an indication of the unknown frequency.

## R.F. measurements

Having dealt with standards and calibration we can now turn our attention to actual measurements of frequency.

**Absorption Wavemeter.**—For measuring radio frequencies, the least complicated instrument is the absorption wavemeter. In its simplest shape this takes the form of an LC circuit as shown in Fig. 72, where the tuning capacitor is fitted with a dial calibrated in frequency.

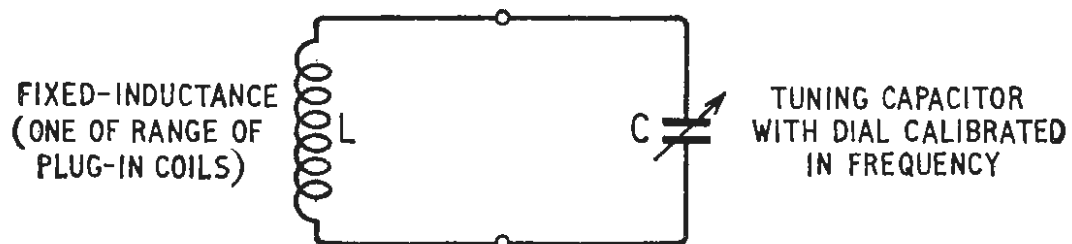

Fig. 72. Basic circuit of absorption wavemeter.

To measure the frequency of a transmitter or receiver, you tune the wavemeter with its coil loosely coupled to the equipment until the equipment response shows a change caused by the absorption of r.f. energy by the wavemeter resonant circuit. By the use of plug-in coils, a wide frequency range may be covered by the absorption wavemeter. Such meters are often fitted with some form of resonance indicator such as a pilot lamp or meter, so that you can see the synchronism with the signal source without having to watch for any change in response in the source equipment.

Wavemeters can be calibrated from a t.r.f. receiver tuned to a standard-frequency transmission, or from any calibrated standard signal generator.

One of the more useful features of the wavemeter is

that it gives a quick identification of the fundamental frequency in the presence of its harmonics, as the circuit is not usually sufficiently sensitive to respond to harmonics.

**Grid-dip Meter (or Oscillator).**—An absorption wavemeter can be used only to check circuits when r.f. energy is present. Some other arrangement is required to check the frequency of a passive tuned circuit. A handy instrument for this is the grid-dip meter. Not strictly a signal

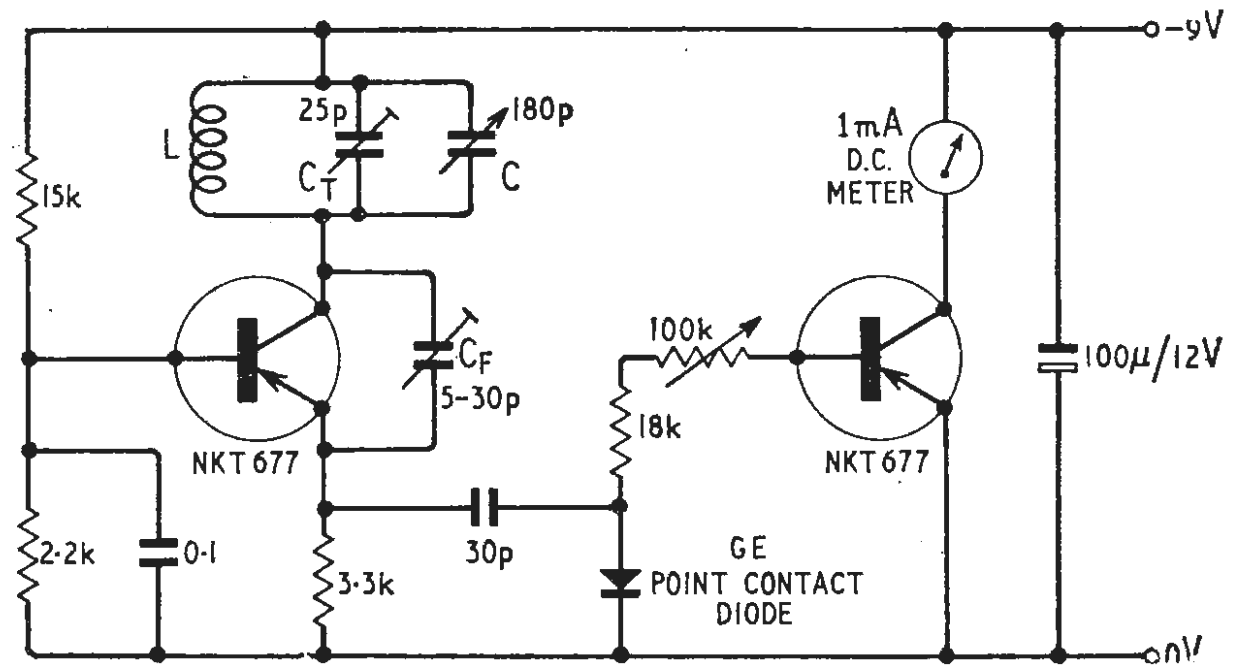

Fig. 73. Circuit of typical "grid-dip" meter capable of operating from 1 to 30 Mc/s with suitable plug-in coils.

generator, it combines the function of a calibrated variable frequency reference oscillator with that of an absorption wavemeter. A typical circuit of a simple transistor grid-dip meter is shown in Fig. 73. In use, the oscillator coil is loosely coupled to the tuned circuit under test, and the grid-dip meter tuned by the main tuning capacitor C until the reading on the millimeter dips to a minimum. What has happened then is that the variable oscillator frequency has been synchronized with the tuned circuit under test, which has absorbed some energy from the oscillator and caused the meter to dip. The frequency of the tuned circuit under test is then read off from the calibrated dial of the master control capacitor C. (The term "grid" in grid-dip meter is a bit of a misnomer. It refers back to the days when these instruments used thermionic valves, but people still talk of the transistor version as a "grid-dip" meter, although the grid has disappeared along with the valve of which it formed part!)

**Heterodyne Frequency Meter.**—Until the recent large-scale increase in the use of counter-type frequency meters, accurate measurements of the frequency of an r.f. signal source were most often carried out by the heterodyne or zero-beat method. This depended on the fact that when two signals of different frequencies are mixed in a non-linear circuit, the output contains a signal at a heterodyne or beat frequency equal to the difference between the two original signals. The heterodyne frequency meter is in effect a standard signal generator fitted with provision for feeding the unknown signal into a mixer along with the internally generated standard frequency signal. The internal generator is then adjusted until the beat frequency is heard on the headphones and the dials are adjusted so that pitch of the beat note progressively decreases until it becomes inaudible. The setting of the heterodyne frequency meter dials then gives the exact frequency of the signal being measured.

A very well-known version of the heterodyne frequency meter is the BC-221 shown in Fig. 74. This

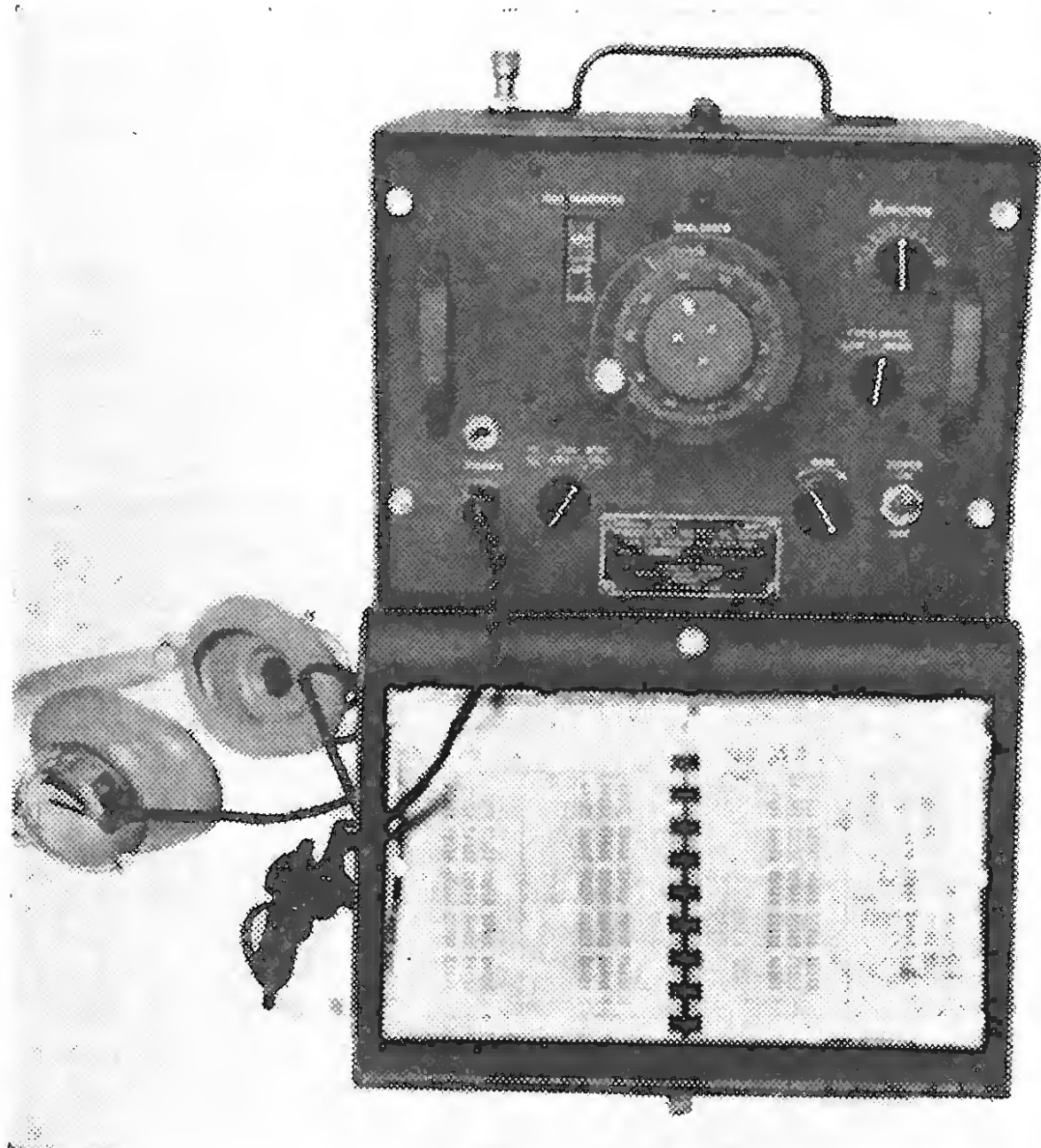

Fig. 74. BC-221 heterodyne frequency meter widely used by the Forces in World War II and readily available on the surplus market.

was widely used by the Armed Forces during the last war as a frequency standard covering 125 kc/s to 20 Mc/s in two ranges. The tuning control is geared to obtain a most precise slow motion of the dial. The setting can be read to five figures, which can then be translated to the exact corresponding frequency by the use of the calibration chart which can be seen in the illustration just below the front panel.

Good heterodyne frequency meters (such as the BC-221) incorporate an internal crystal calibration oscillator against which the variable frequency oscillator can be adjusted at a series of check points by means of a small vernier control. With this facility, the readings of the BC-221, for example, can be made accurate to 0.01% (1 in  $10^4$ ).<sup>†</sup> However, the BC-221 is capable of an accuracy of better than  $\pm 30$  c/s over most of the 125 kc/s to 20 Mc/s range.

**Counter-type Frequency Meters.**—Digital counting techniques have advanced so much over the past ten years that counter-type frequency meters are available which can measure accurately and display numerically frequencies well into the u.h.f. range. A good example of such a meter is the Marconi Type TF2401 illustrated in Fig. 75. I dealt with the principles of operation of this type of frequency measuring equipment in part 10 of "Elements of Transistor Pulse Circuits"<sup>‡</sup> (W.W., November 1964).

## AF measurements

Some methods of measuring radio frequency discussed above can also be used at audio frequencies. For

<sup>†</sup>Accuracies of about 1 in  $10^7$  are quoted for some frequencies in "Get More from LM and BC-221 Frequency Meters" by G. Jennings, *Radio-Electronics*, August 1962, p. 63.

<sup>‡</sup>The series of articles is now available as a book.—Ed.

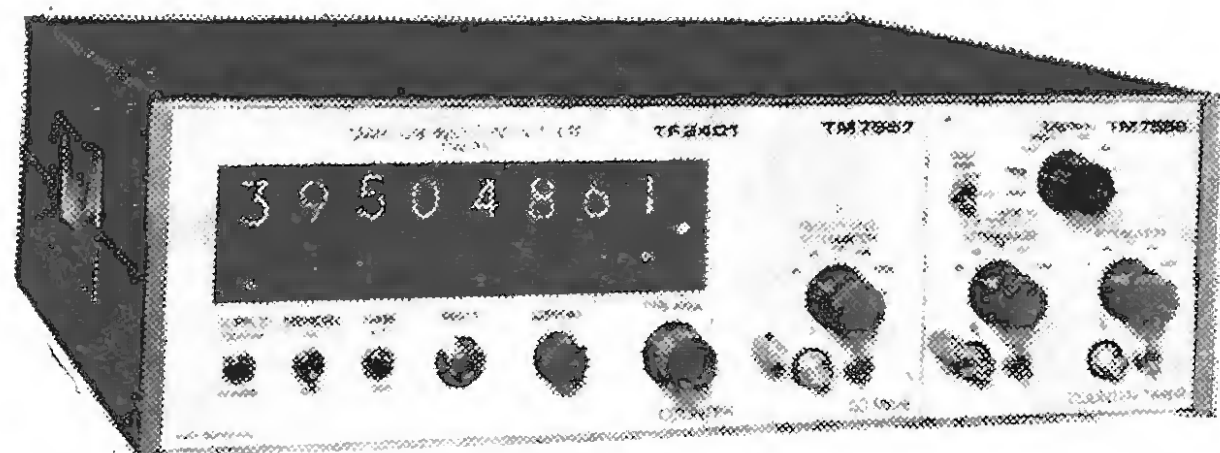

Fig. 75. Modern-high performance commercial counter-timer frequency meter (Marconi TF2401) capable of counting up to 500 Mc/s with absolute accuracy of better than 1 in  $10^7$ .

example, the counter-type frequency meter can equally well be used for audio frequency measurements of very high accuracy, although in an ordinary laboratory such measurements by themselves would hardly justify the considerable expense of a v.h.f. counter-timer to be used at a.f.

For audio work up to 20 kc/s, the slower dekatron counters, often still found around laboratories, can be used satisfactorily for many purposes. I myself have used a Labgear Fast Dekatron Counter Type D4131 for measuring the precise frequencies required to an accuracy of 0.01% (i.e. 1 in  $10^4$ ) in electronic organ tuned circuits, and found it quite adequate when used with the ancillary crystal-controlled frequency source and timing unit available.

**Bridge Measurements.**—In the audio frequency range relatively simple resistance-capacitance circuits have such time constants as to be frequency sensitive. This gives rise to a range of resistance-capacitance bridge circuits which can be used with suitable calibration to measure audio frequencies.

The Wien bridge, which has only two simultaneously variable components, is often used for this purpose, particularly as it has a very wide frequency range with one swing of the control. This bridge is a venerable one which some readers may be interested to trace

Fig. 76. Typical circuit of Wien-bridge type audio-frequency measuring bridge.

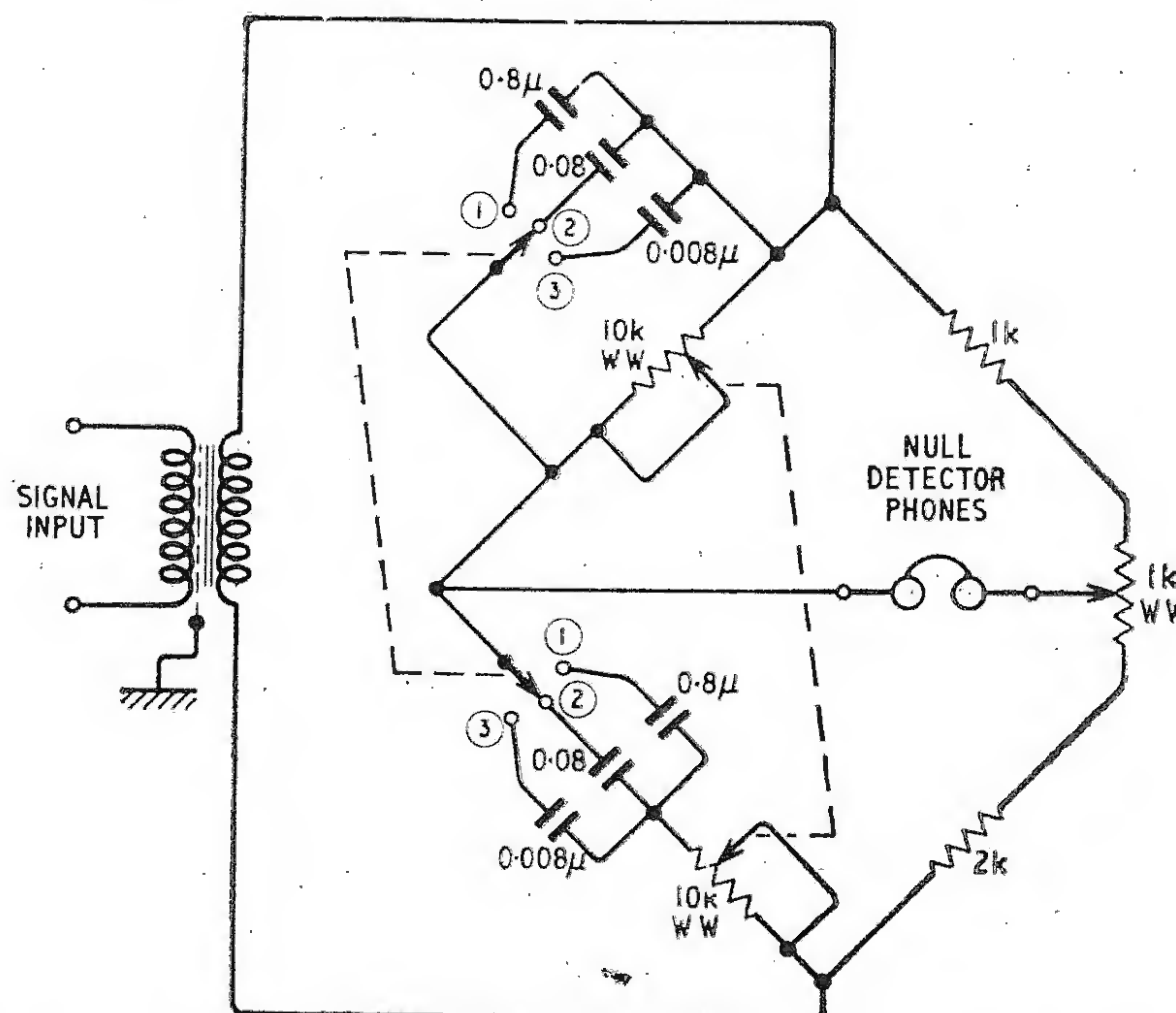

SWITCH POSITIONS: ① = 20-200c/s ② = 200-2,000c/s ③ = 2,000-20,000c/s

back to Max Wien's "Messung der induction constanten mit dem optischen telephon," *Ann. der Phys.*, 44 (1891), pp. 696-697.

Fig. 76 gives a typical circuit of an audio-frequency measuring bridge working on the Wien bridge principle. In this, the two 10 k variable resistances are ganged sections of a double potentiometer, and are so arranged that the resistances of the two arms of the bridge in which they are connected are equal at all settings. The 1 k linear potentiometer at the opposite end of the bridge is a balance resistance that compensates for small differences in tracking between the two 10 k sections of the main variable control resistance. This ganged variable resistance is the principal control on the bridge and is fitted with a calibrated direct-reading dial of frequency. Switched series and parallel capacitors for different frequency ranges will be noted. Those in position (1) are for 20-200 c/s, in position (2) for 200-2,000 c/s, and position (3) for 2,000-20,000 c/s. The dial is calibrated in the first instance against a standard signal source, the setting at each frequency being adjusted for minimum signal in the bridge detector headphones. Once calibrated, the bridge can be used to measure exactly any audio frequency in the range 20 c/s to 20,000 c/s.

The Wien bridge is not a very accurate frequency measuring instrument when compared with the 1 in  $10^6$  easily obtained with a counter-type meter. On the other hand a well-constructed Wien bridge meter can measure frequency to an accuracy of 0.5%, i.e., 5 in  $10^3$ .

**Electronic (Capacitor-Discharge) Frequency Meter.**—A meter-type instrument which does not require balancing or zero-beat adjustments is sometimes a convenience. For this, apart from counter-type meters referred to above, direct reading frequency meters are available working on the periodic discharge of a capacitor. Fig. 77 gives the circuit of a simple transistor meter of this type. The signal to be measured is applied at the input point A, and, whatever its periodic waveform, is transformed by the Schmitt-trigger shaping circuit Tr1, Tr2 into a fixed square-wave shape of constant amplitude. The square-wave output of Tr2 is differentiated by capacitor C\* and applied to the base of the pulse amplifier Tr3. The 50 k variable upper base bias resistor of Tr3 is preset so that the transistor is just bottomed when no input signal is applied. As a result, positive going spikes arising from the differentiation lead to negative-going square pulses of the same duration at the output of Tr3, while negative-going spikes are clipped off. The resultant string of negative-going pulses of fixed height and duration from the collector of Tr3 is applied to the base of Tr4 and gives a mean reading in the d.c. milliammeter in

its emitter circuit directly proportional to the input signal frequency. Accuracies of the order of 2-3% can be obtained with capacitor-discharge frequency meters such as this.

**Calibrated Scope Measurement of A.F.**—An instrument not specifically designed for frequency measurement that is very often used by practising engineers to measure audio (and even low radio) frequencies is the oscilloscope. Nowadays good quality scopes have timebases sufficiently accurately calibrated in time per horizontal scale division to enable you to measure the frequency of an unknown signal. To do this, you set up a scope display of the signal with one cycle occupying horizontally as much of the graticule as possible. If you then count the horizontal scale divisions corresponding to one cycle, you can work out the period  $T$  and thus the frequency  $f (=1/T)$ . Accuracies of a few per cent can be obtained in this way for audio frequencies (or even low r.f., depending on the timebase maximum speed).

## V.H.F./U.H.F. measurements

Measurements of very high frequencies follow much the same pattern as r.f. measurements, except the various equipments may take special forms. For example, the simple absorption wavemeter described earlier will, in the u.h.f. range, take the shape of a pair of Lecher wires, or a calibrated cavity resonator, or a slotted line.

As mentioned before, standard frequencies in these ranges are derived by multiplier circuits (usually triggered astable multivibrators or tuned frequency harmonic multipliers) from r.f. standards. Tuned Class C thermionic valves can be pushed out in this way to a few thousand megacycles and klystrons to 25,000 Mc/s. Microwave and variable capacitance diodes are also used for frequency multiplication into the microwave frequency range.

We have taken a look at most of the instruments used in laboratories to measure frequency. Although these have been widely relied on in the past, the development of economical portable transistor counter-type frequency meters capable of giving an instantaneous direct digital readout display of frequencies up into the u.h.f. range, must mean that in the years to come many of the instruments described in this article must become lab. curiosities. However, the slow natural term of obsolescence of electronic instruments means that readers may still have to know how to handle them and understand their principles for some time to come.

Fig. 77. Circuit for transistor capacitor-discharge, direct reading audio frequency meter.

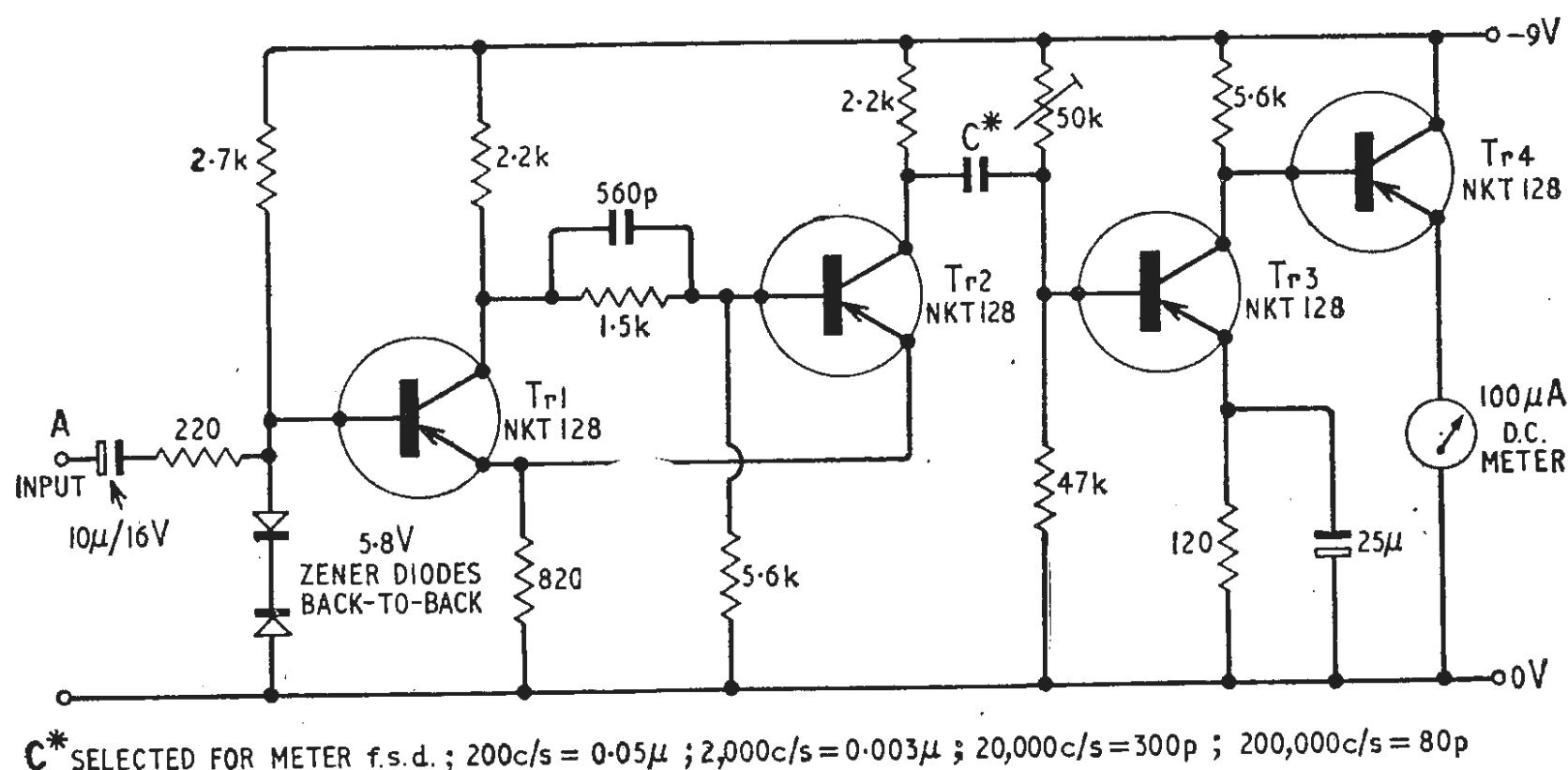

# ECONOMICAL LOGIC

Advantages of NAND/NOR logic and techniques for using it—with particular reference to minimization of networks by topographical methods

By H. R. HENLY,\* A.M.I.E.E.

THE tremendous developments in semiconductor technology in recent years have made possible the design of logic circuit elements which are reliable, efficient and suitable for mass production. In particular the combination of diodes and/or resistors with transistors to produce NAND and NOR elements has revolutionized the design of computer and process control logic.

As the following discussion will show, the application of NAND/NOR logic techniques to the realization of logic circuits results in a number of distinct advantages, both economic and in circuitry, over those elements representing the basic Boolean connectives AND and OR. A reminder of the logic systems and terms in common use is given in the box, right. (Unless otherwise stated, positive logic will be used throughout the article. On graphical symbols, the recommendations of BS530 are considered to be perfectly adequate and will be used throughout.)

The design philosophy based on AND and OR connectives has the advantage that, apart from the emitter followers, the elements represent fundamental Boolean connectives. With suitable choice of diodes, high operating speeds may be realized at comparatively low cost. However, this must be weighed against the degradation of signal levels, which may worsen with age. Also, the use of these circuits does not necessarily produce

\* Post Office Engineering Department.

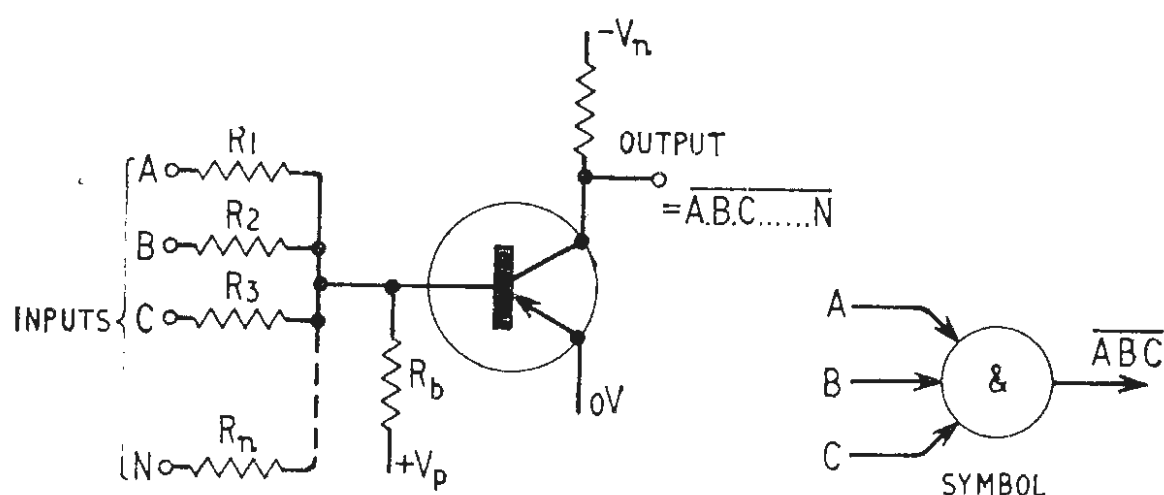

Fig. 1. Simple NAND element: transistor circuit and graphical symbol.

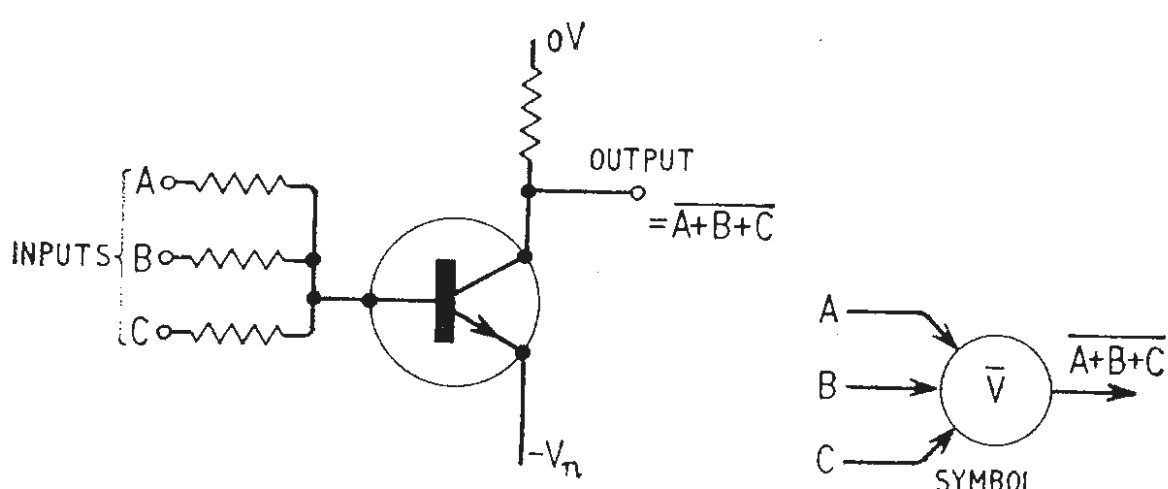

Fig. 2. Simple NOR gate, circuit and symbol.

## AND/OR/NOT Logic Realization

The truth values 1 and 0 are represented electronically by two discrete voltage (or current) levels, one of which is generally (but not necessarily) zero (earth) potential. Two logic systems may be defined:—

(1) *Positive Logic* in which the truth or 1 value is represented electronically by the more positive of the two levels chosen.

e.g.  $+6$  volts = 1  
0 volts = 0

(2) *Negative Logic* in which the truth or 1 value is represented by the more negative of the two levels chosen, e.g.:

$+6$  volts = 0  
0 volts = 1

The fundamental Boolean connectives are realized electronically by diode gates (below). These are

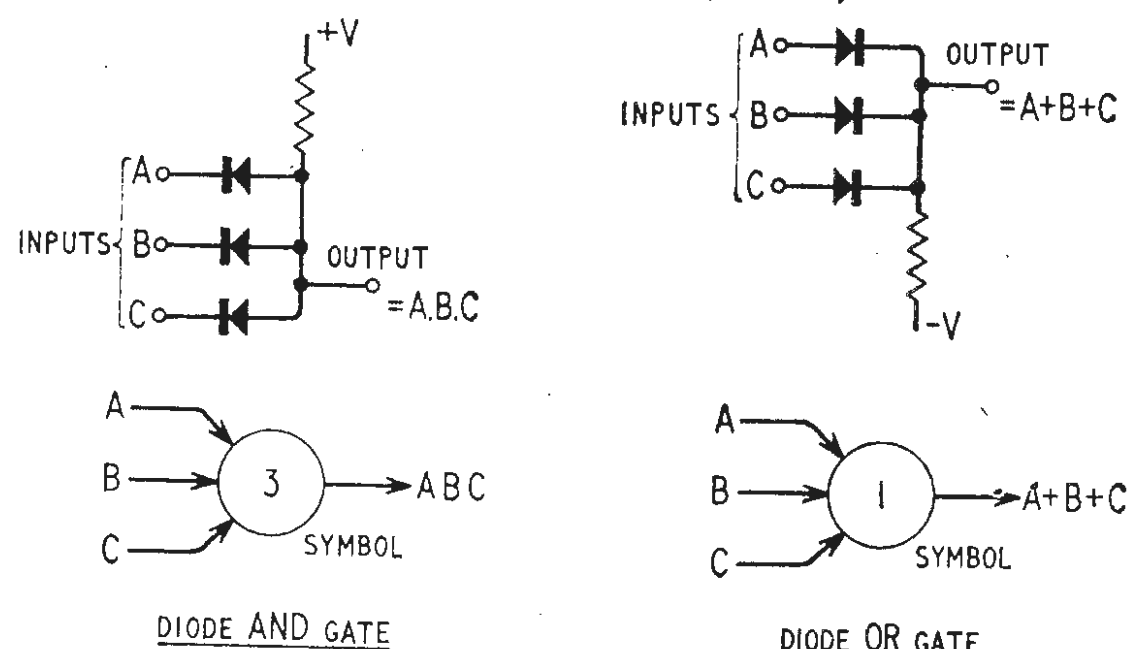

cheap and simple in construction but suffer from the disadvantage that no active device is included, resulting in a power loss at each stage of gating. The result is a gradual deterioration of signal levels which is overcome in practice by the inclusion of emitter followers at strategic points in the circuit. The NOT operation is performed by the common-emitter stage (below) which provides both inversion

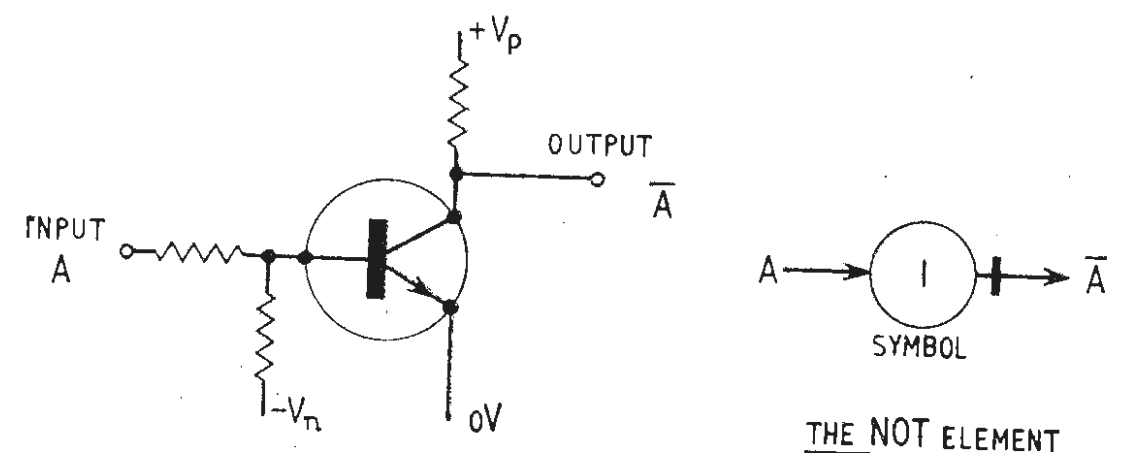

and power gain and may be used instead of emitter followers where rearrangement of the circuit equations permits.

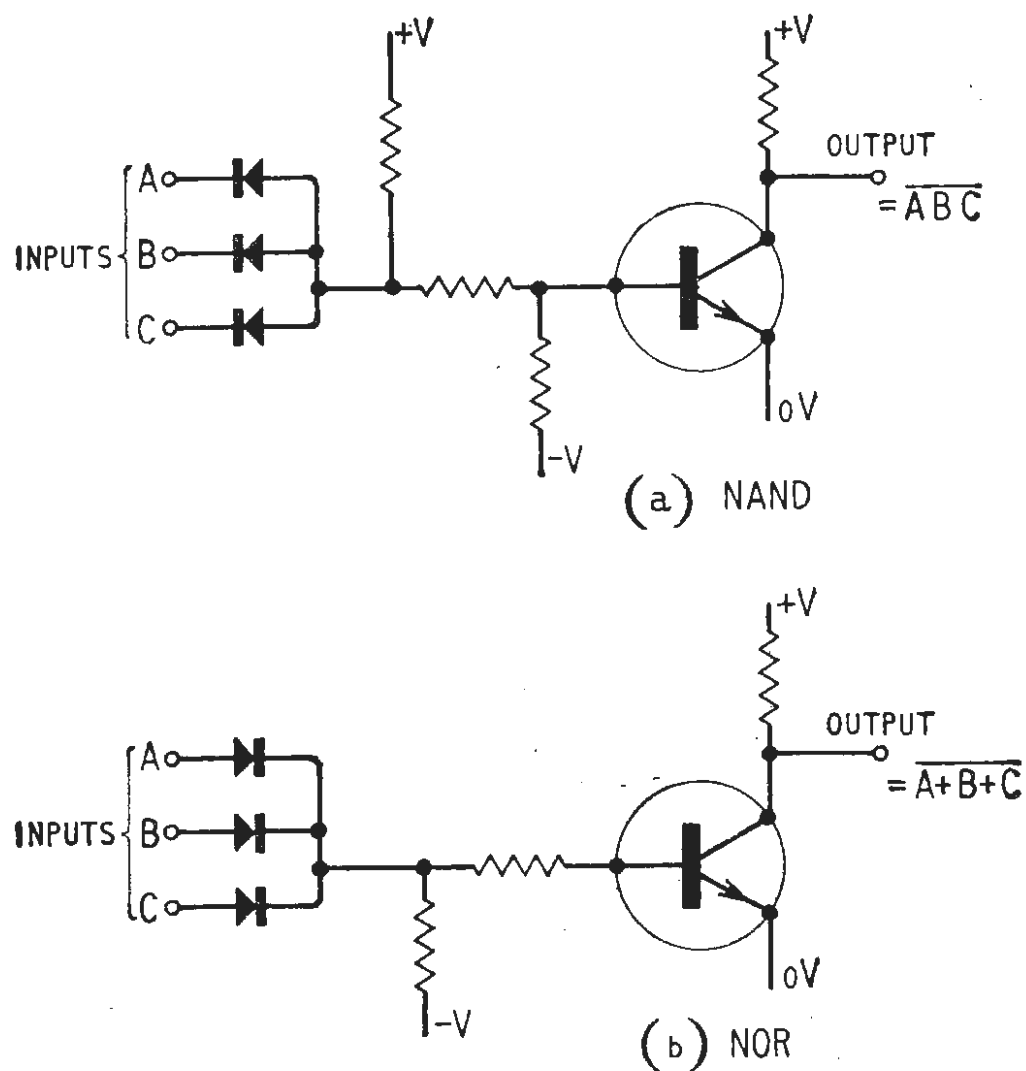

Fig. 3. Alternative NAND and NOR elements.

the most economic realization of a given circuit equation in terms of electronic components. This is particularly true now the price of transistors, diodes and high-stability resistors are of the same order.

The NAND and NOR elements are simply developments of the NOT element, comprising in the simplest form the common-emitter circuit of Fig. 1. A number of inputs are provided via resistors  $R_1, R_2 \dots R_n$ , to the transistor base. These are so chosen that with all inputs at zero potential relative to the emitter (i.e. 1 level) the potential divider formed with the base resistor  $R_b$  across the positive supply  $V_p$ , cuts off the transistor. Under this condition the output is approximately  $-V$  volts (0 level). The operation, assuming three inputs, is clearly

$$Z = \overline{ABC} \text{ i.e. } = \text{NOT-AND or NAND} \dots \dots (1a)$$

or by De Morgan's theorem

$$Z = \overline{A} + \overline{B} + \overline{C} \dots \dots (1b)$$

If the p-n-p transistor of Fig. 1 is replaced by an n-p-n type, as in Fig. 2, then with the same logic levels we have the following operation:—

$$Z = \overline{A+B+C} \dots \dots (2a)$$

i.e. NOT-OR or NOR  
or by De Morgan's theorem,

$$Z = \overline{A} \cdot \overline{B} \cdot \overline{C} \dots \dots (2b)$$

In order to ease the tolerancing problem and increase the operating speed, the alternative circuits of Fig. 3 may be used. These utilize diode gates followed by inversion. Although the overall cost is higher, the reliability (especially using silicon devices) is greater. Furthermore, compatible NAND and NOR circuits may be designed (i.e. to allow the interconnection of NAND with NOR circuits).

The NAND and NOR circuits described may be

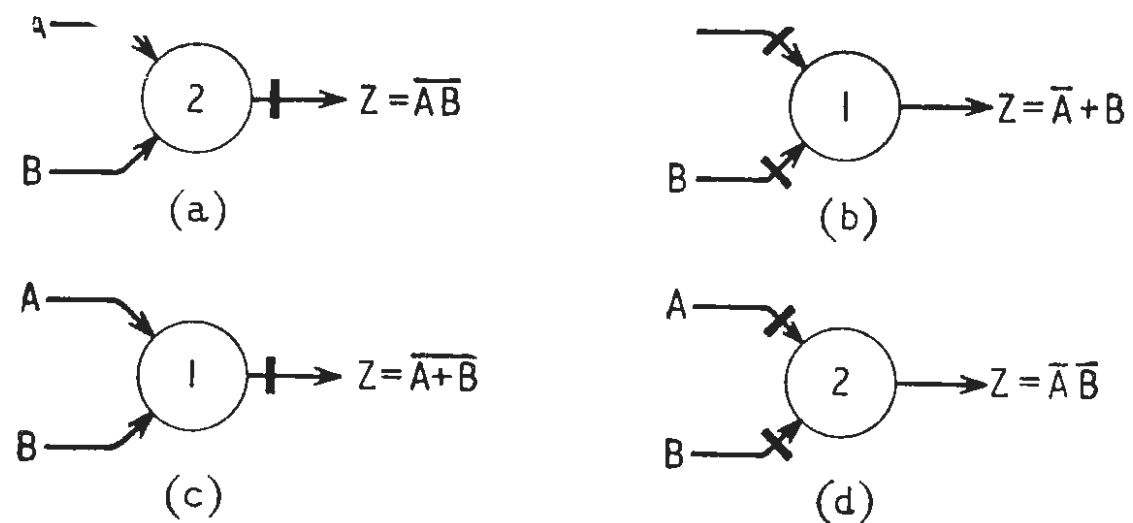

Fig. 4. Symbolic interpretation of equations (1) and (2).

designed as a standard element so that any element is capable of driving a certain number (typically 5) of identical elements. This enables the system designer to implement a logic circuit using one standard circuit element throughout, provided care is taken to ensure that the loading restrictions for the element are followed. Where it is essential to exceed the driving capabilities of the simple element, several may be combined (effectively paralleling the transistors) or another standard circuit designed with a larger driving capacity.

Thus even in its simplest form, Fig. 2 represents a very powerful logical element—a fact which has been exploited to advantage by manufacturers in the computer and automation fields.

In terms of the basic connectives we may derive the equivalent circuits of these elements by making use of equations 1 and 2. These are shown in Fig. 4 and it is seen that the elements may be considered simply as combinations of AND and OR gates with inverters.

There are a number of methods whereby circuits may be implemented in NAND/NOR logic. The first and probably simplest technique for implementing a circuit is the substitution method. The Boolean expression is first translated into AND and OR elements and these are replaced by their NAND/NOR equivalent circuits. The equivalent circuits, are easily derived and are tabulated below.

FUNCTION	INTERPRETATION IN BASIC CONNECTION	NAND EQUIVALENT CIRCUIT	NOR EQUIVALENT CIRCUIT
$Z = ABC$			
$Z = A+B+C$			
$Z = \overline{A}$			

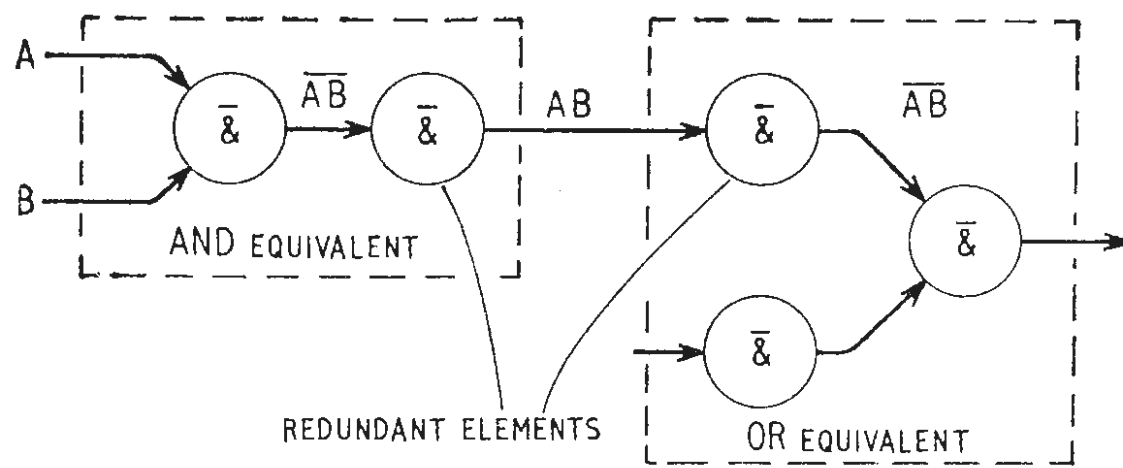

Fig. 5. Redundant elements in cascaded NAND circuits.

After the substitution the circuit is examined for redundant elements, e.g. two NOT elements in cascade. The resulting circuit is not necessarily the minimal form (assembled from the smallest possible number of elements) even though the original Boolean expression may have been.

The derivation of the equivalent circuits does yield one useful fact, of which we shall make use later. It is seen in Fig. 5 that if an OR equivalent circuit follows an AND equivalent circuit (in the case of NAND elements) two single-input elements are saved per OR input. A similar situation occurs with NOR elements when an OR circuit is followed by an AND circuit.

A	B	f
0	0	0
0	1	1
1	0	1
1	1	0

$$f = A\bar{B} + \bar{A}B$$

Truth table for Exclusive OR function.

To exemplify this technique and to introduce other ideas we shall consider the Exclusive OR circuit. The Truth table is given above, from which we obtain the function:

$$f = A\bar{B} + \bar{A}B \quad (3)$$

If this is implemented in the basic connectives it requires two AND elements for the product terms, an OR element for the output gate and two inverters. The circuit is shown in Fig. 6(a). Substituting the appropriate NAND equivalent circuits in 6(a) and removing redundant elements yields the circuit of Fig. 6(b). This uses five elements and eight inputs, so a simpler solution is

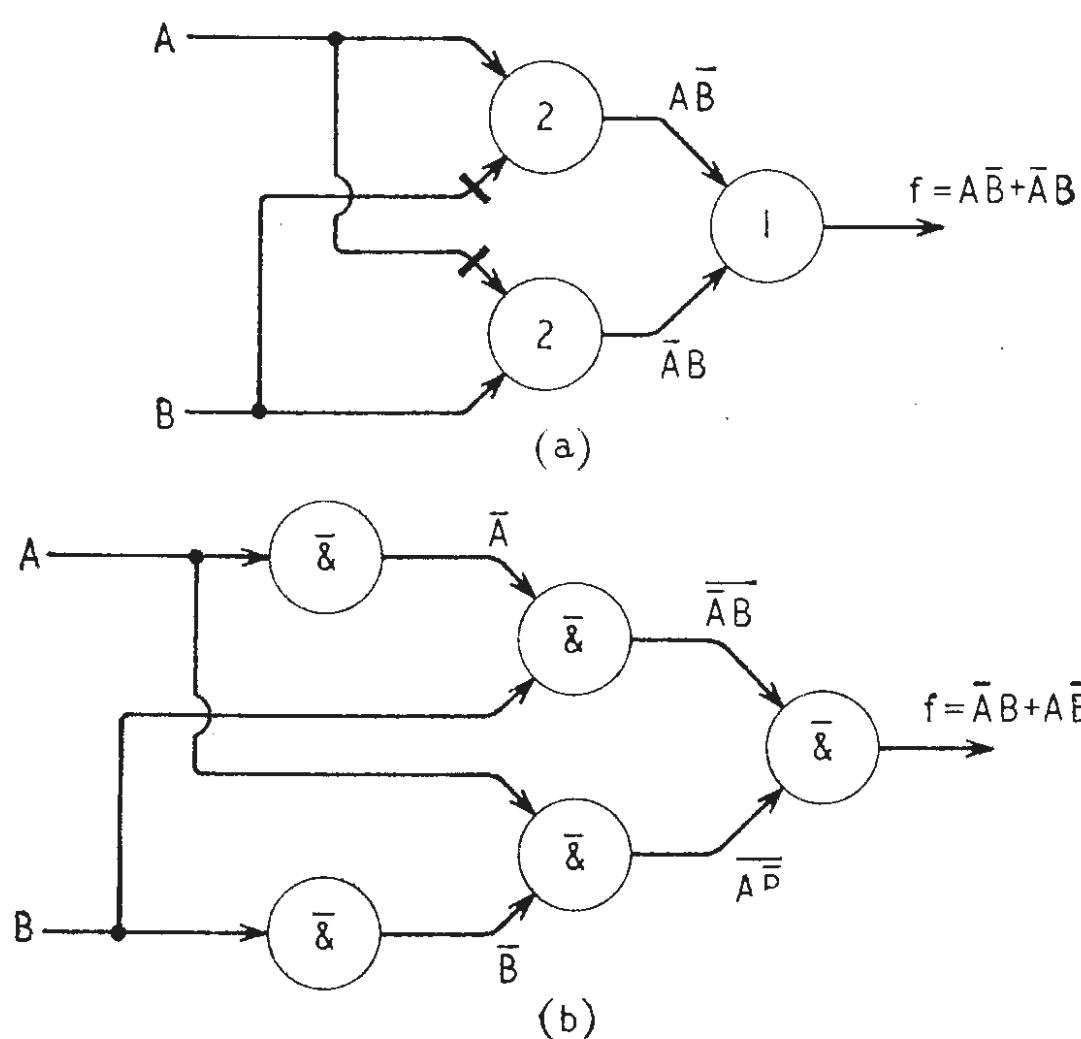

Fig. 6. (a) Basic logic diagram for equation (3); and (b) implementation of equation (3) in NAND elements.

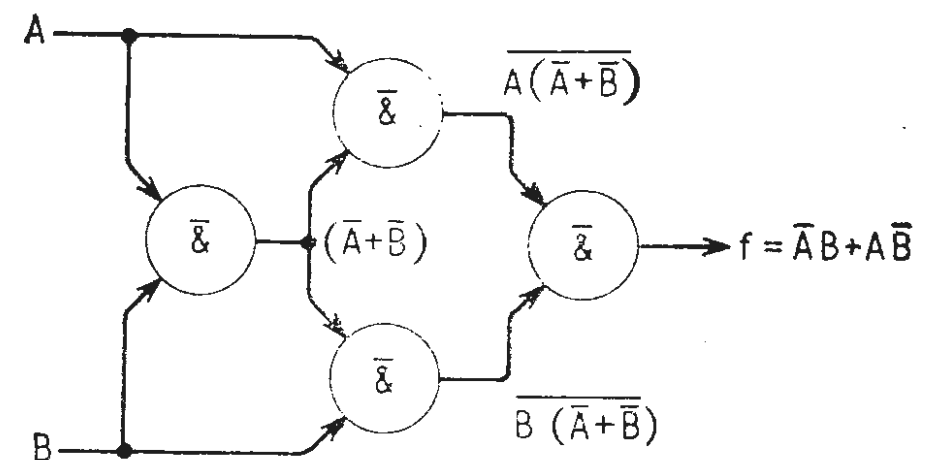

Fig. 7. NAND implementation of equation (4).

sought. Returning to equation 3, by the distributive laws we can write:

$$\begin{aligned} f &= (A\bar{B} + \bar{A}) (A\bar{B} + B) \\ &= (\bar{A} + \bar{B}) (A + B) \\ &= (\bar{A} + \bar{B})A + (\bar{A} + \bar{B})B \end{aligned} \quad (4)$$

Now the equation is in the form AND-OR-AND, with a common factor  $(\bar{A} + \bar{B})$ . The NAND implementation is shown in Fig. 7, requiring only four elements and eight inputs, and has been shown to be the minimal form<sup>2</sup>. This brings out the important point that although the substitution method yields useful results the circuit is not necessarily the minimal form. It may be necessary to rearrange the circuit equations into a form which represents the output of NAND/NOR elements. It should also be noted that equation 4 yields the minimal circuit in basic connectives by writing it as:

$$f = \bar{A}\bar{B} (A + B)$$

requiring only three elements and one inverter—a saving of one inverter.

It is instructive to take this example a stage further and consider the NOR form. From equation 4 we have:

$$f = (\bar{A} + \bar{B}) (A + B)$$

but instead of partially multiplying out to obtain the sum-of-products form we retain the product-of-sums form, from which the NOR form is obtained directly, Fig. 8. This is the minimal NOR form requiring five elements and eight inputs and is therefore less economic than the NAND version.

It is important to note that here we sought an equation which required the output to perform an AND function whereas for the NAND version we made the output

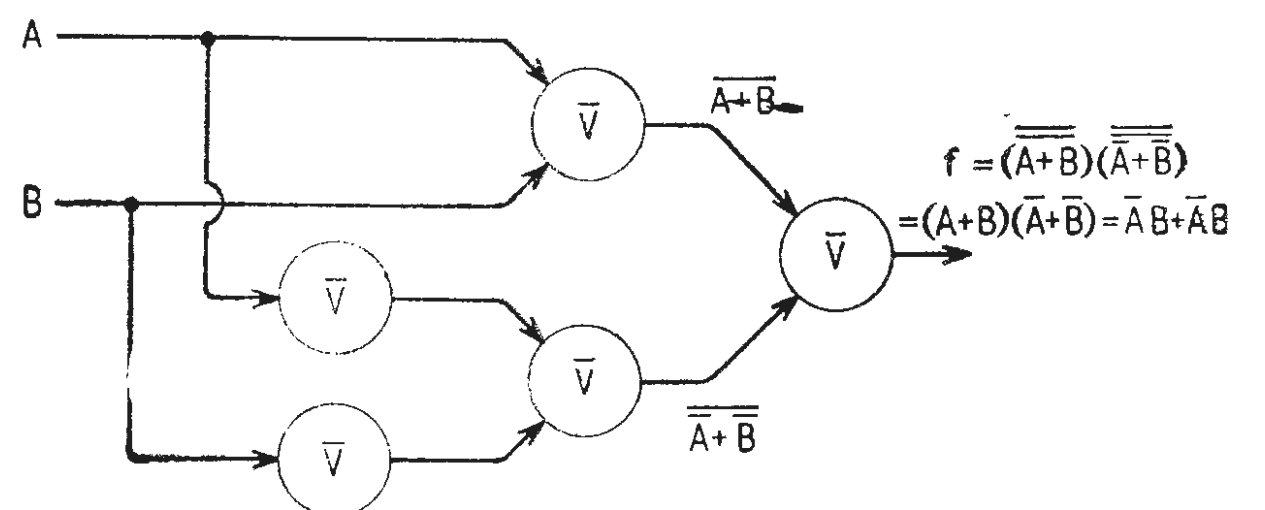

Fig. 8. NOR form of equation (4).

gate perform an OR function. Let us consider this point more closely. Referring to the circuits of Fig. 4, it can be seen why these arrangements are desirable.

First consider the case of two NAND elements feeding an output NAND gate, Fig. 9(a). Analysing this in terms of the basic Boolean connectives, we arrive at Fig. 9(b), remembering that De Morgan's theorem gives two alternative forms for a NAND function. It is seen that the complementations occurring in the penultimate stages of gating are cancelled in the last stage.

(continued on page 521)

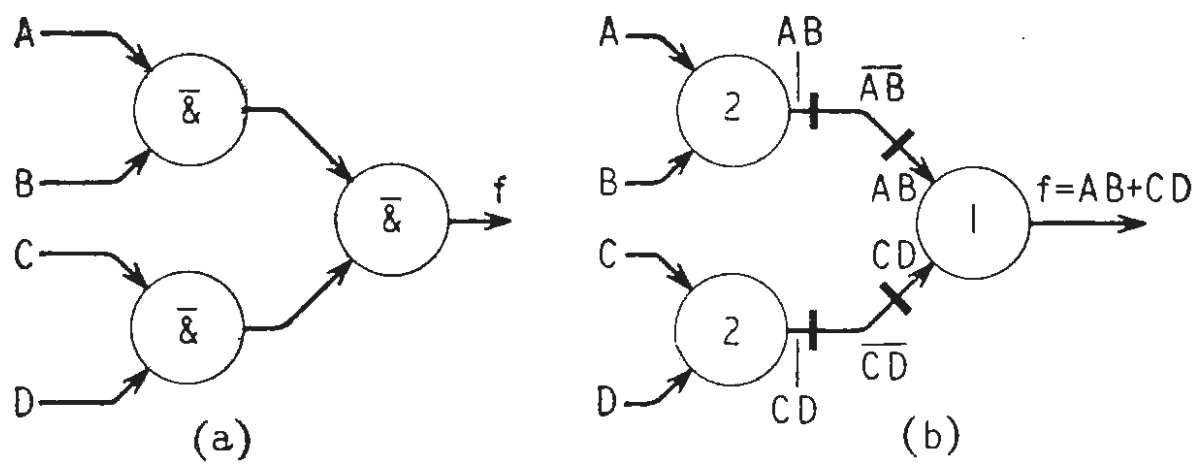

Fig. 9. (a) Analysis of NAND circuit; (b) analysis of (a) in terms of basic connectives.

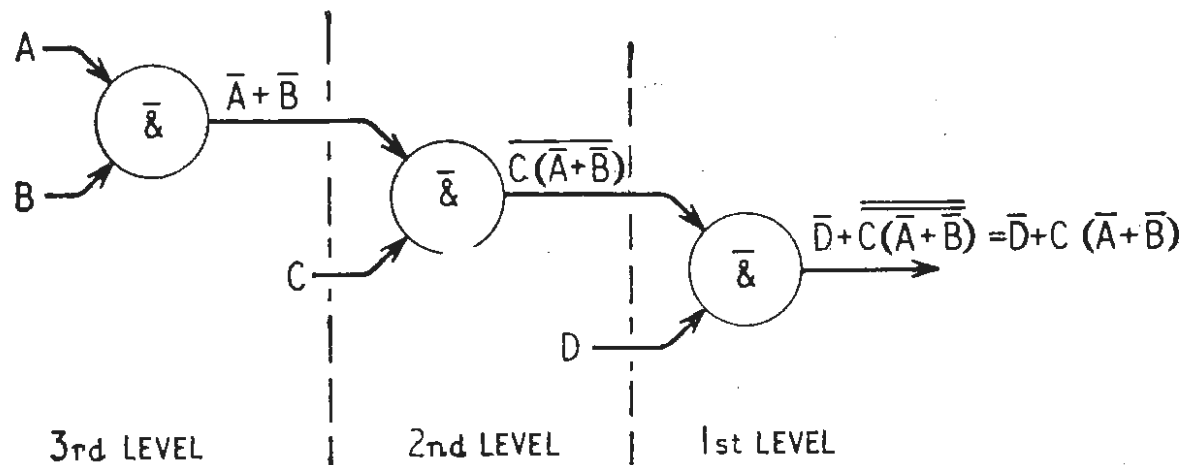

Fig. 10. General NAND circuit, indicating three levels of gating.

It is conventional to number the stages of gating from the output, i.e. the output stage is the first stage, all stages driving it constitute the second stage and so on.

The above exercise can be repeated using NOR elements, and a similar analysis results. The output function would be the dual of Fig. 9(b), since dual elements would be used. Again by using the appropriate equations (from De Morgan's theorem) terms complemented in the second stage of gating would be complemented again in the first (output) stage. In general it can be concluded that variables entering at the first stage appear complemented at the output whereas those entering at the second stage appear uncomplemented at the output. This conclusion will now be developed into a general theory.

Consider Fig. 10, which shows part of a larger circuit involving three levels of gating. Here it is seen that terms entering at odd levels (1 and 3) appear complemented at the output, whereas variables entering at the even level (2) are unchanged at the output. It is left to the reader to establish the same rule for NOR elements.

From the foregoing results, general rules for the implementation of NAND/NOR logic can be formulated. These follow identically the rules devised by Maley and Earle<sup>2</sup> and provide an extremely powerful tool for the logic designer.

### Rules for implementing NAND/NOR logic

1. Write the equations in a minimal form, suitable for the type of element it is proposed to use. (i.e. in the Sum-of-Products form for the implementation in NAND elements).
2. Draw the circuit using the basic Boolean connectives.
3. Replace each element with a NAND (or NOR) element and complement terms entering at odd levels which are required uncomplemented in the output. Where possible the original equation should be rearranged so that terms to be complemented at the output enter at odd gating levels, thus saving inverters.

As an example of the technique consider the function  $f = A\overline{B} + \overline{B}C$ . This is already in a suitable form for

NAND logic, i.e., a sum-of-products form, so we can immediately draw the Boolean circuit of Fig. 11(a). From this follows Fig. 11(b), in which each element is replaced with a NAND block, including the inverter to give  $\overline{B}$ .

In order to implement the same function using NOR elements it is necessary to rewrite the original equation in the product-of-sums form, i.e.

$$f = A\overline{B} + \overline{B}C = \overline{B}(A + C)$$

by simple factorization. The two stages of implementation are shown in Figs. 12(a) and 12(b). In this case B is inserted at the first gating level to produce  $\overline{B}$  at the output.

In this example the NOR configuration produces the more economic circuit, in terms of components, since it involves only two elements and four inputs in contrast to four elements and seven inputs for the NAND version (Fig. 11).

It is important to note the above rules result in no loss of minimality, i.e. the NAND (or NOR) form obtained by these rules will be no less minimal than the original Boolean form.

### Minimization

The techniques discussed above provide a ready means of implementing a function in NAND/NOR logic after it has been reduced to its minimal form by the various minimization techniques.

Since the problem of minimization represents a large and often tedious part of the design, I will discuss certain techniques which are considered to be best suited to the design of circuits involving only a few variables (up to 6 or 8). Minimality is not an invariant property of a function since it depends entirely upon the type of circuit element to be used. For the present purposes we need only consider elements using diodes and transistors.

Where diode logic is concerned, each term (sum or product) involves one diode for each literal of the term. Complemented terms require inverters involving transistors.

For circuits using NAND/NOR logic each term requires a transistor and each literal of the term requires an input resistor. Where the circuits used are tailor-made, i.e. inputs are provided only as required, it is clearly desirable

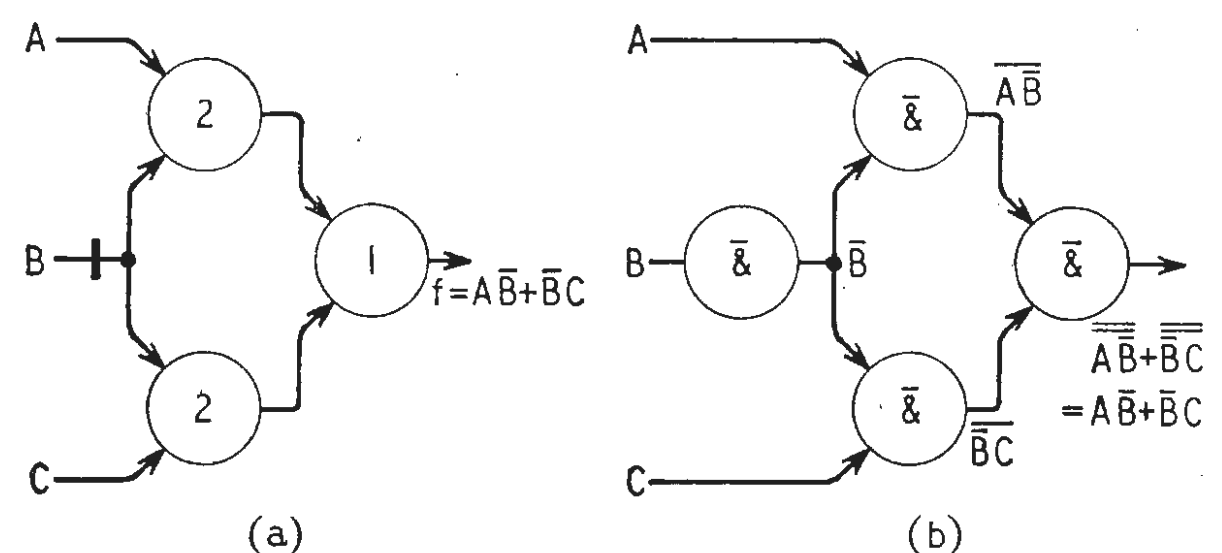

Fig. 11. Test example  $f = A\overline{B} + \overline{B}C$ , given (a) in basic connectives and (b) with NAND implementation.

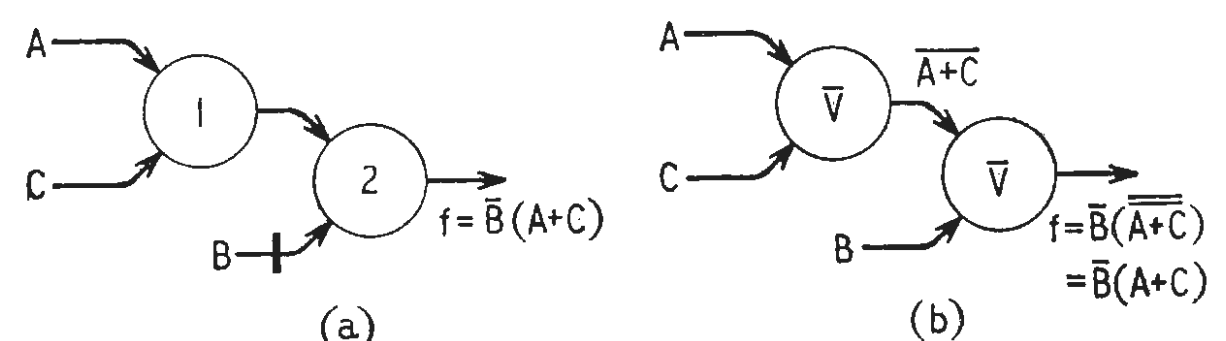

Fig. 12. Implementation of test example in NOR elements.

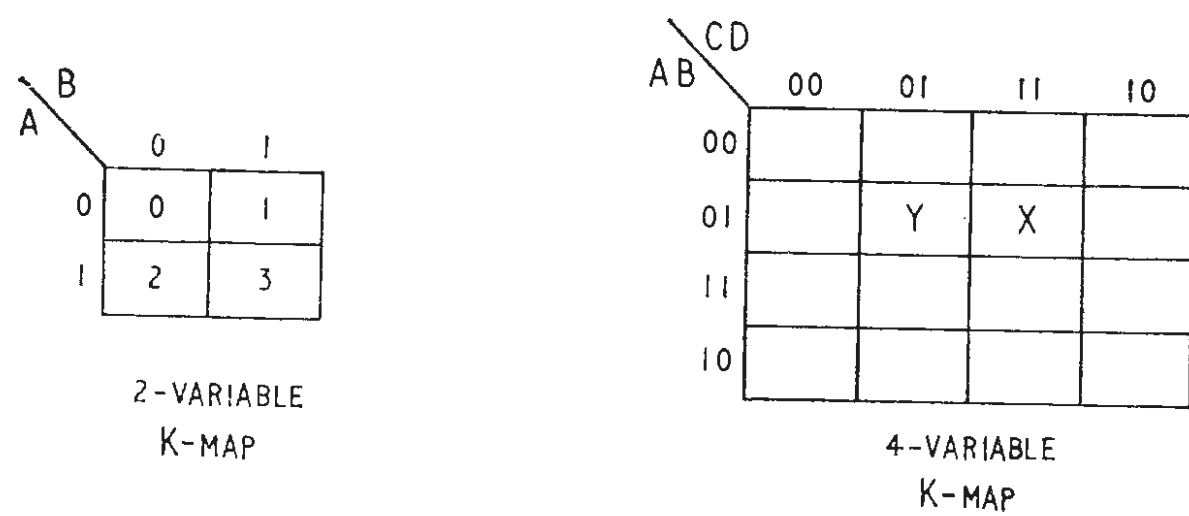

Fig. 13. Karnaugh maps.

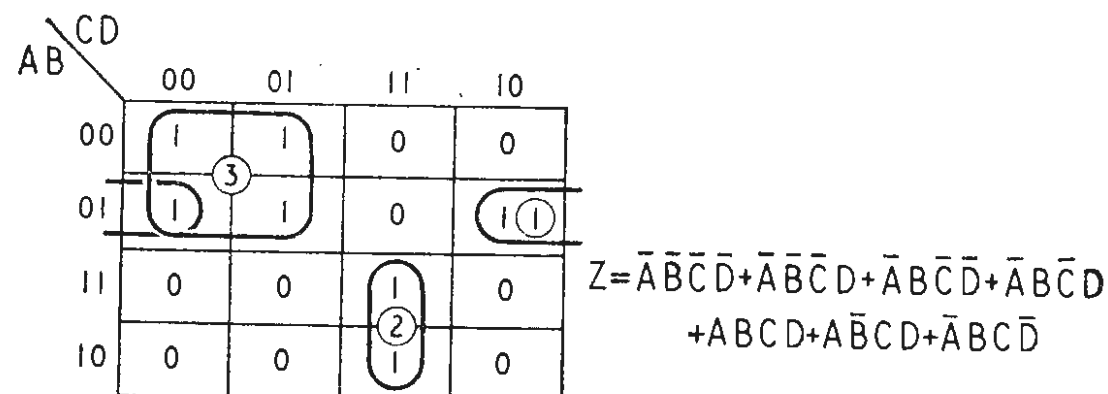

Fig. 14. Karnaugh maps for the function  $Z$  shown. The circled decimal numbers within the loops are used for reference in the text.

to minimize the number of literals as well as the number of terms. However, it is common practice to use standard elements which are produced by many manufacturers for this purpose and take one of two forms. The most popular at present is the type using discrete components, encapsulated in an epoxy-resin and designed for maximum reliability. The second and more recent form is the integrated circuit or micro-logic element. In these elements complete NOR circuits are made from a single chip of silicon<sup>5</sup>, resulting in one or more logic elements condensed into a very small package (typically a TO5 transistor case).

The use of these elements eases the minimality requirements to that of reducing the number of terms (elements) required and keeping the number of inputs to an element within the number provided. Furthermore the output loading restrictions on the elements must also be observed.

Integrated circuit techniques have developed even further, to the stage where complete logical functions can be constructed on one "chip" of silicon. This completely changes the minimality criteria and makes the direct application of these techniques difficult. Although redundancy is still undesirable it has often to be accepted in these circuits in order to ease the problems of layout and input/output connections to the circuit. This problem has been discussed recently by J. Earle<sup>6</sup>.

The problem of minimization may be tackled in many ways, e.g. algebraic, tabular or map methods. All make use of the axioms  $A + A = A$ ,  $A + \bar{A} = 1$ ,  $A\bar{A} = 0$ , and  $A + AB = A$ , to reduce the original canonical form to one involving only those terms required to completely describe the function. These terms are called prime implicants. It is proposed to discuss below the Karnaugh map method due to M. Karnaugh<sup>1,2,3,4</sup>. This is a development of the Veitch map, which, with binary ordering of the axes, is considered by the author to be superior to other methods (for problems involving six to eight variables).

The map for  $n$  variables comprises  $2^n$  cells arranged in either a plane or three-dimensional array. One cell is assigned to each of the  $2^n$  canonical product terms. Examples of two and four-variable maps are shown in

Fig. 13. The axes are labelled according to a reflected binary (Gray) code which represents the various combinations of the variables assigned to that axis (e.g. for variables  $A, B$  the term  $\bar{A}B$  is represented by 01). The advantage of the reflected binary ordering of the axes lies in the fact that adjacent cells differ in one variable only. For example, in the two-variable map of Fig. 13, the cell labelled 2 represents the term  $A\bar{B}$  since it lies at the intersection of  $A = 1, B = 0$ . Similarly in the four-variable map the cell marked  $x$  represents the term  $\bar{A}B.C.D.$ , that is,  $A = 0, B = C = D = 1$ . Furthermore the cell  $y$  represents  $\bar{A}B.\bar{C}.D.$ , and it differs from the adjacent cell  $x$  in the variable  $C$  only.

The map for a given function is drawn up directly from the truth table by entering a "1" in each cell for which the output is desired to be "1." The function is then the sum of all the terms for which a "1" is entered on the map. Furthermore any terms occupying adjacent

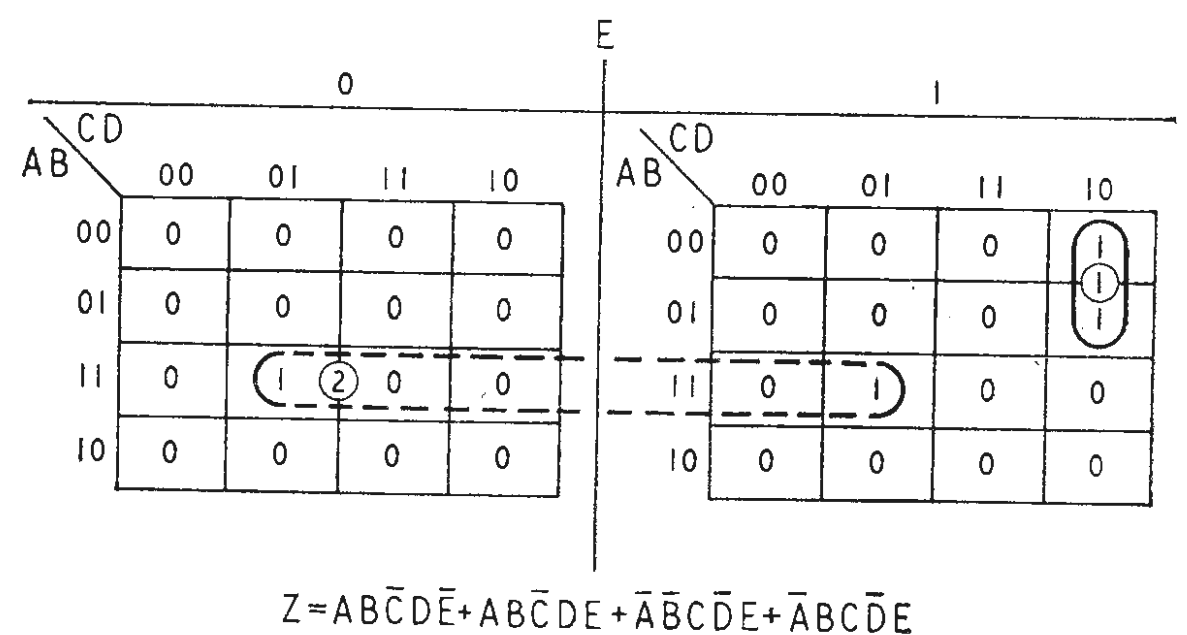

Fig. 15. Five-variable Karnaugh map.

cells in the map may be combined to remove one redundant variable, i.e. that one in which the terms differ. For example in Fig. 13, terms  $x$  and  $y$  differ in the variable  $C$  and the result of combining these terms is  $\bar{A}B.D.$  Terms which may be combined in this way are indicated by looping together on the map, as shown in Fig. 14, which is a map for four variables. Loops 1 and 2 each involve two terms only, and it will be observed that loop 1 involves terms on opposite edges of the map; this is consistent since these cells also differ in one variable only.

Loop 3 involves four terms; the argument used here is simply an extension of that used above. Loop 3 may be considered as four loops of two. This yields:—

$$\begin{aligned} Z &= \bar{A}.\bar{B}.\bar{C} + \bar{A}.\bar{C}.D + \bar{A}B.\bar{C} + \bar{A}.\bar{C}.\bar{D} \\ &= \bar{A}.\bar{C}(D + \bar{D}) + \bar{A}.\bar{C}(B + \bar{B}) \\ &= \bar{A}.\bar{C} + \bar{A}.\bar{C} \\ &= \bar{A}.\bar{C} \end{aligned}$$

Now this result could have been obtained by simply looping the four terms as shown and eliminating those variables which change value in moving horizontally and vertically across adjacent cells ( $B$  and  $D$  in this case).

Furthermore, terms may be included in more than one

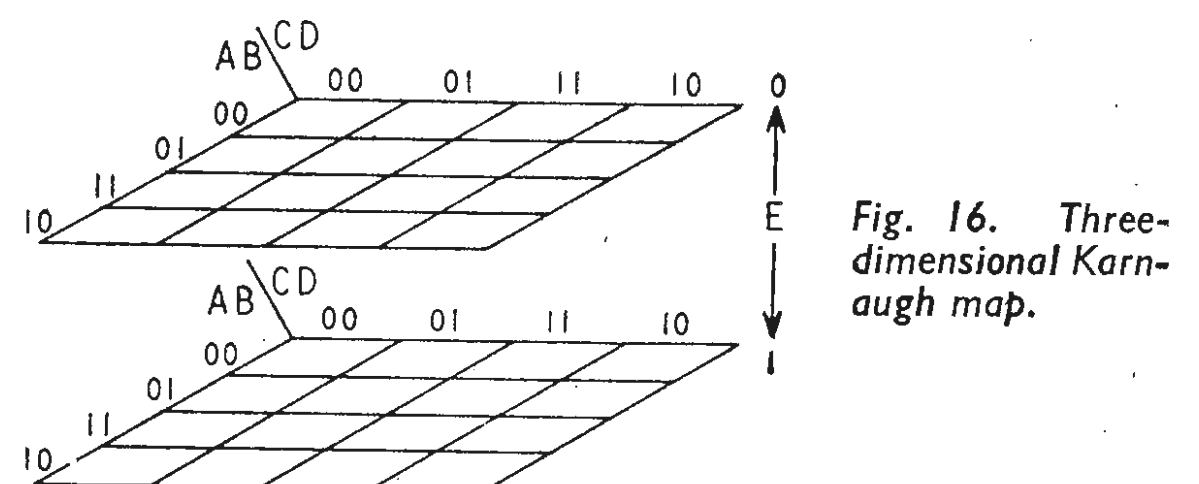

Fig. 16. Three-dimensional Karnaugh map.



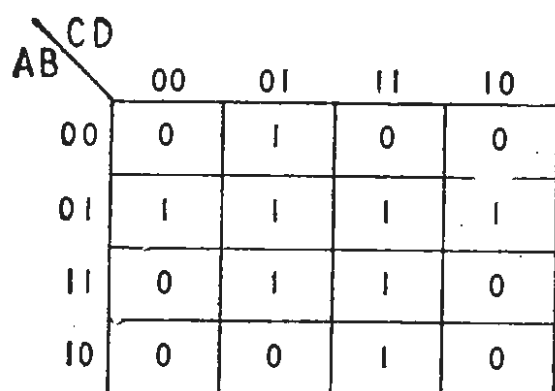
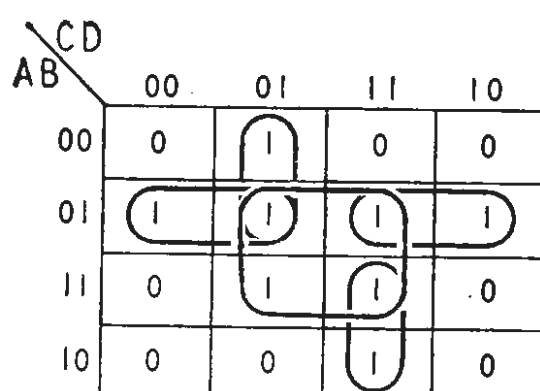
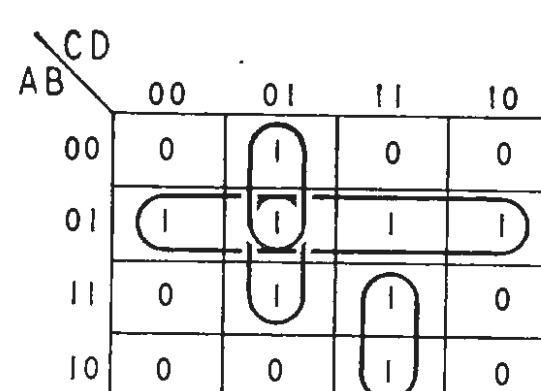

Fig. 17. Karnaugh map with a number of possibilities for looping two terms.



$$Z = BD + ABC + \bar{A}BC + ACD + \bar{A}\bar{C}D$$

(a)



$$Z = \bar{A}B + \bar{A}\bar{C}D + B\bar{C}D + ACD$$

(b)

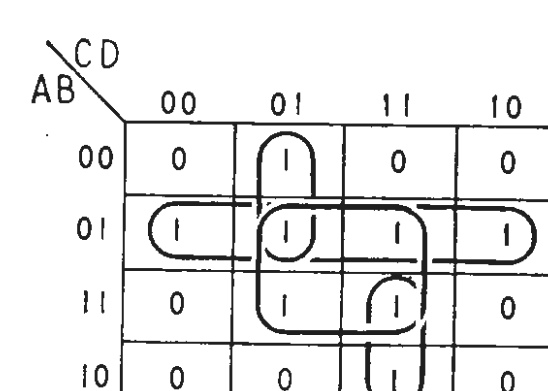

$$Z = \bar{A}B + BD + ACD + \bar{A}\bar{C}D$$

(c)

Fig. 18. Three possible loopings of Fig. 17.

loop, since  $A + A = A$ , but this should not be done carelessly since it can result in unnecessary terms being included.

In the four-variable map of Fig. 14, it will be observed that two variables are assigned to each axis. This is not mandatory and the variables may be assigned in any desired fashion. However, one complication arises where the binary coding involves more than two variables—that is, the cell adjacencies. In the case of two variables, only adjacent cells differ in one variable; with more than two variables there will also be non-adjacent cells which differ in one variable. For example, consider the three-variable code:

	<b>A</b>	<b>B</b>	<b>C</b>
	0	0	0
	0	0	1
}	0	1	1
	0	1	0
	1	1	0
	1	1	1
	1	0	1
	1	0	0

Apart from the ordinary adjacencies there are two additional terms which should also be considered "adjacent"; these are shown bracketed. If this code were used for one axis of a four-variable map (for example, with a simple one-variable code on the other axis), then these additional adjacencies must not be overlooked. The problem would not arise if the simpler, two-variable codes were used (i.e. one for each axis).

Maps may of course be constructed for any number of variables, although above six they tend to become unwieldy. For five variables the number of cells is large ( $2^5$ ) and the adjacencies are less obvious. For five variables it is advantageous to draw two four-variable maps, as in Fig. 15. Then clearly loops may exist on either map for example loop 1, or between maps as indicated by loop 2. In this example  $Z = A.B.\bar{C} + A.C.\bar{D}.E$ . Alternatively the maps may be considered as lying one above the other, as shown in Fig. 16.

In the examples so far there has been no difficulty in selecting loops on the map. However, in general there is usually a number of ways in which the ones may be looped and it is essential that the combination yielding the minimum number of loops be chosen. Consider Fig. 17. There are many possible loops of two terms; but there are two possible loops of four and the question arises—which combination to choose? Fig. 18 shows three possible combinations. The first (a) is obviously not the best choice since it involves five terms plus an output gate. Combination (b) is an improvement, but (c) has fewer terms complemented. The unnecessary terms and literals in the first two arose because the loops chosen were not as large as they could have been.

The guiding principle in selecting loops is to first select loops of single ones which cannot be combined to make loops of two. Then make those loops of two ones which will not make loops of four; then loops of four which will not make loops of eight, and so on.

This procedure is continued until all "1's" have been looped at least once. Where more than one combination of loops is possible each must be tried and the final selection made on the basis of the number of loops and literals involved (including the number of complemented terms).

Of course, we are not restricted to using the "1's" on a map; the zeros represent product terms for which the output is zero. Consider the function dealt with earlier  $f = A.\bar{B} + \bar{B}.C$ . The map for this function is

Fig. 19. Example of looping map zeros.

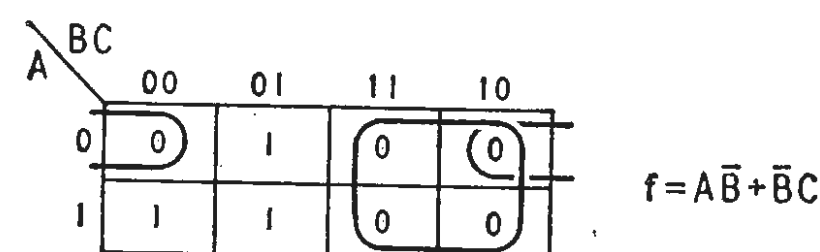

shown in Fig. 19, and one loop of four and one loop of two zeros are possible, yielding:

$$\begin{aligned} \bar{f} &= B + \bar{A}.\bar{C} \\ f &= \overline{B + \bar{A}.\bar{C}} \\ &= \bar{B} (\overline{\bar{A}.\bar{C}}) \text{ by De Morgan} \\ &= \bar{B} (A + C), \text{ the original function.} \end{aligned}$$

Here we have merely shown that the zeros of the map produce the same result as the ones. Thus in minimizing a function we may also consider looping the zeros and select the looping which yields the minimal covering (i.e. the smallest number of prime implicants).

The above discussion, of course is by no means an exhaustive treatment of the methods by which the minimal form of a logical function may be determined.

**Acknowledgement.**—I would like to acknowledge the permission of the Engineer-in-Chief, G.P.O., Engineering Dept., to publish this paper and also the help and encouragement of my colleagues in its preparation.

#### REFERENCES

1. Phister, Montgomery. "Logic Design of Digital Computers," Wiley, New York (1960).
2. Maley, G. A. and Earle, J. "Logic Design of Transistor Digital Computers," Prentice-Hall, New York (1962).
3. Marcus, M. "Switching Circuits for Engineers," Prentice-Hall, New York (1962).
4. Caldwell, S. H. "Switching Circuits and Logical Design."
5. S. G. S. Fairchild, Application Reports and Micro-logic Handbook.
6. Earle, J. "Boolean Algebra Fails to give the Right Answers," *Electronic Design*, 7th Dec. 1964, p.34.
7. Henly, H. R. "Logic Without Tears," *W. W.*, Feb. 1965.

# Keeping the Radio Peace

## CENTENARY OF THE INTERNATIONAL TELECOMMUNICATION UNION

**A**LMOST as soon as wireless telegraphy proved itself to be a practical means of communication the need for rules and regulations became evident; clearly, anarchy would lead to chaos. Apart from that, the new form of telegraphy might well constitute a threat to established state monopolies in communication. So it was that quite early in the present century many countries enacted laws to control radio. The first British Wireless Telegraphy Act was passed in 1904. Even before then, as ranges of signalling increased rapidly from tens to hundreds of miles, it became obvious that domestic control was not enough. In 1903 the German government called a conference to undertake preliminary studies for the international regulation of radio. This was largely by way of protest against the refusal of Marconi-controlled stations to communicate with other "systems." Delegates from nine nations attended. Though little was actually accomplished, useful groundwork was done for the first real international conference, held in Berlin in 1906.

Fortunately, machinery for co-operation in radio communication between the nations already existed, almost ready made, in the form of the International Telegraph Union. For 41 years the I.T.U. had proved itself to be highly successful in organizing the exchange of telegraphic and later telephonic communications across national frontiers.

### "Semaphore to Satellite"

This year the I.T.U. celebrates its centenary and, to mark the occasion, has issued a lavishly illustrated book\* on its wire and wireless activities over 100 years, with short histories of the various forms of communication. The I.T.U.'s Centenary Conference opened in Geneva on 14th September.

Apart from its more serious content and the great historical value of the excellently reproduced illustrations, the book throws light on many lesser happenings in international communication history. For instance, few of us will know that Britain did not qualify for admission to the Union when it was formed in 1865; her telegraph system was then privately owned. She joined in 1871, after the telegraphs had been nationalized by Disraeli. The U.S.A. did not adhere to the Convention until 1932 though she had been a kind of honorary member long before then. Her earliest radio laws, passed many years after those of the other great nations, were largely in conformity with I.T.U. principles. Naturally, a fair amount of space is given in the book to successive radio conferences. The first, that held in Berlin in 1906, was in some ways the most significant of all as it set the pattern for the future international use of radio for the benefit of all. Frequencies were allotted for specific uses and rules were framed for procedure and priorities in the exchange of telegrams. Delegates from 29 countries attended and they agreed that the I.T.U. should act as the central administrative organ.

Frequency allocation was then a delightfully simple matter; anyone could carry the complete list in his head. The

mercantile marine and coastal stations were given 500 and 1,000 kc/s; the band 188-500 kc/s was reserved for "services not open to public correspondence" (which meant mainly naval and military stations) while frequencies below 188 kc/s were for long-distance point-to-point services. These regulations came into force in 1908 and so were those current when *Wireless World* started publication.

The next conference, meeting in London in 1912, was held under the shadow of the *Titanic* disaster and so was concerned largely with measures for increasing the safety of life at sea. No very significant changes in frequency allocations were made, though radio beacons were allowed to use frequencies above 2,000 kc/s. There was so far no shortage of channels, though what was to prove the most difficult of problems began to loom over the horizon. At about this time Mr. Winston Churchill, First Lord of the Admiralty (probably briefed by Admiral Jackson), pleaded in Parliament for haste in setting up the stations of the proposed "Imperial Chain"; otherwise there might be no channels available. And he may well have been right; allowing for the great spread of the spark transmitters envisaged for that grandiose but (perhaps fortunately) still-born scheme, there was not over-much room in the band of wavelengths "within the limits of 17,000 and 50,000 feet" as specified for the proposed stations.

Due to the First World War, there was a big gap until the next conference, that in Washington in 1927, which is rightly described in the centenary book as "the first of the modern telecommunication conferences." Many new developments had arisen, among them valves, radio telephony, broadcasting and world-wide h.f. communication. The range of frequencies now allotted was from 10 kc/s to 60 Mc/s. To cope with the vastly increased complexity of the I.T.U.'s task the International Radio Consultative Committee (C.C.I.R.) was now set up. Its function was "to study technical and operating questions relating specifically to radio communications and issue recommendations on them." There are now no fewer than 14 C.C.I.R. study groups. From the start, propagation has always been prominent and the subject is always under review to help towards solving changing radio problems. Noise of all kinds is equally fundamental and there is close collaboration in its study between the C.C.I.R. and the International Radio Scientific Union (U.R.S.I.).

### I.T.U. organization

Subject matter of subsequent conferences became too complex for even a brief survey here, but some of the decisions produced profound changes in the I.T.U. itself. In 1932 wire and wireless, sinking old rivalries, came together; the I.T.U. became the International Telecommunication Union and joint committees were set up. In 1947 the I.T.U. became a specialist agency of the United Nations. Sweeping changes were made and it was constituted as a truly international body with no national obligations. Hitherto the staff had been Swiss, appointed by the Swiss government. The Union's permanent Bureau had been set up in Berne as long ago as 1868 in order to distribute statistical and tech-

(Continued on page 525)

\* "From Semaphore to Satellite." Pp. 343; 365 illustrations. International Telecommunication Union, Place des Nations 1211, Geneva 20, Switzerland. Price 40 Swiss francs.

nical information to members. Now, according to the latest figures available, there is a permanent I.T.U. staff of 142 persons—they might be called international civil servants—drawn from 36 different countries. The Bureau moved to new headquarters in Geneva in 1962.

As might be expected, the Union suffers under the curse of Babel. Its "working" languages are French, English and Spanish, with French as the "authentic" language in cases of dispute. Chinese, English, French, Russian and Spanish are classed as "official" languages. In the early days all the radio publications were in French only.

To cope with fluctuating monetary exchange rates the I.T.U. has had to devise its own notional currency unit for the settlement of international terminal and transit charges for traffic. This is the "gold franc" defined as consisting of 10/31 gram of gold of purity 0.900.

"Undoubtedly the toughest and most intractable problem which has confronted the I.T.U. during the second half of its first 100 years of existence has been the allocation, assignment, registration and orderly use of radio frequencies." It was to provide improved machinery for solving this problem and clearing away the chaos of the Second World War that another offshoot of the I.T.U., the International Frequency

Registration Board (I.F.R.B.) was set up in 1947. The Board, with 11 elected members of different nationalities, has a semi-judicial function in securing immunity from interference for duly registered stations.

Space communication has of late been one of the concerns of the I.T.U. It was in 1959 that a study group of the C.C.I.R. began to study these special problems. Frequency bands totalling over 6,000 Mc/s have now been allotted to the various space services, either on a shared or exclusive basis. A frequency (20.007 Mc/s) has even been allotted for distress calls from space vehicles. The band 1400-1427 Mc/s has been freed for exclusive world-wide use in radio astronomy.

One of the avowed aims of the Union is "to harmonize the action of the nations" in working towards the better use of telecommunication channels. To have achieved that aim in a world of increasingly prickly nationalism, in which broadcasting and communication services are almost national status symbols, is a matter for legitimate self-congratulation—especially as there are now over 120 member nations of the I.T.U. Judging by the fact that during the whole of its 100-year history not a single member has ever resigned, the Union may justly claim to have succeeded. H. F. S.

---

## Books Received

**Worked Examples in Electronics and Telecommunications**, Vols. 1 and 2, by B. Holdsworth and Z. E. Jaworski. The first two of four volumes which together will cover the syllabus in preparation for the B.Sc. final examinations in electronics and electrical engineering as well as the graduation examination of the I.E.E. Volumes 1 and 2 together cover the syllabus of Pt. II electronics and a portion of Pt. II electrical theory and measurement. The authors have used actual examination questions from the past few years, and in preparing the answers have outlined basic principles before giving a general solution. Vol. 1 "problems in electronics" deals with 70 problems under the headings general circuit theory; coupled circuits; electron ballistics; valve parameters and equivalent circuits; voltage amplifiers; power amplifiers; oscillators and valve non-linearities; and power supplies and filters. Vol. 2 "problems in electronics theory and communications" deals with 47 problems under electric and magnetic field theory; transmission lines; electro-acoustics; transients; harmonics; and illumination. Vol. 1, pp. 209; Figs. 121. Price 25s. Vol. 2, pp. 134, Figs. 71. Price 22s. 6d. Iliffe Books Ltd., Dorset House, Stamford Street, London, S.E.1.

**Dictionary of Electronics, Communications and Electrical Engineering**. Volume II German-English, edited by H. Wernicke. The author is head of the translating department of the West German company of Rohde and Schwarz. Volume II contains approximately 66,000 words (6,000 more than the English-German volume issued previously), and includes not only the English equivalents of German words but also of abbreviations. Pp. 576. H. Wernicke, 8024 Deisenhofen, Munich. Available in U.K. price 56s from Aveley Electric, South Ockendon, Essex.

**Electronics Buyers' Guide**. The 1965 edition of this comprehensive and invaluable directory of the American electronics industry consists of three sections:— a 450-page buyers' guide with over 3,600 product headings (from abrasives to zirconium); an alphabetical index to manufacturers and their branch offices and, in some cases, overseas agents; and 400 pages of manufacturers' announcements. It weighs 5½lb! Pp. 1338. Issued free to subscribers to *Electronics*. McGraw-Hill Publishing Inc., 330 West 42nd Street, New York.

**The Dynamics of Linear and Non-linear Systems**, by P. Naslin. An English edition, translated by the author, of the original book "Les régimes variables dans les systèmes linéaires et non linéaires." Intended for electrical, mechanical and control engineers, the work is an exhaustive, detailed analysis of control systems. In the introduction, the system concept and general properties of linear and non-linear systems are defined. Graphical and numerical methods of analysis follow, demonstrating the analogies between different types of system. Further deeper analysis employs transform methods, stability and damping criteria, phase-plane and phase-safe topological methods, and numerical and graphical computation of transients. Pp. 586; nearly 520 Figs. Price £5 5s. Blackie & Sons Ltd., 5 Fitzhardinge Street, Portman Square, London, W.1.

**Television Engineering & Television Electronics**, edited by P. Neidhardt. A technical dictionary in four languages—English, German, French and Russian—listing approximately 3,500 terms used in television and electronic technology. Linguistic cross referencing of the terms has been made by dividing the book into four language sections. The terms are first printed in the language of the section and then followed by the three translations. Pp. 340. Price £7. Pergamon Press Ltd., 4 and 5 Fitzroy Square, London, W.1.

**Design and Construction of Transistor Superhets**, by R. H. Warring. Intended for amateur-radio enthusiasts, the book is essentially practical in treatment. After a simple introduction to the principles of the superhet, an explanation of transistors and printed circuit assemblies is given. Stages of the superhet are then covered in more detail prior to a description of professionally designed circuits. The final chapters deal with constructor kits, testing and alignment. Pp. 104; Figs. 70. Price 17s 6d. Museum Press Ltd., 26 Old Brompton Road, London, S.W.7.

**The Elements**, by S. Ruben. A short, well arranged reference book of interest to both students and engineers, detailing the chemical and physical constants of 103 elements. Although not applicable to each element, 23 constants are covered, and each element is presented on an individual page. Price 15s. W. Foulsham and Co. Ltd., Yeovil Road, Slough, Bucks.

# NEW PRODUCTS

## MARINE ECHO-SOUNDER

THE latest addition to the Marconi International Marine Company's range of echo-sounders is the Contour, a precision instrument giving a resolution of up to 0.2 in/ft. The new recorder uses a servo-controlled ceramic pen, heated by a 6 V coil, and which writes on heat-sensitive recording paper.

A linearly-increasing voltage (with time) provides a voltage proportional to depth and this is quantized and applied to an integrator which allows only the strong seabed echoes to register and ignores weak echoes from fish, etc. The desired signals are then passed through a d.c. chopper amplifier to a phase-shifting stage. The phase-shifted signal and a local reference signal are then fed to a two-phase motor, in a balanced bridge, which drives the pen.

The transmitter provides about 1 kW peak power at about 50 kc/s and pulse duration is 200  $\mu$ s, 1 ms or 2 ms, depend-

ing on the range of operation. Soundings can be made at the rate of 40 to 100 per minute. The three depth ranges are 2.5-30 ft, 2.5-30 fathoms and 25-300 fathoms, and the range in use is indicated automatically at the recorder. The recording paper is 7 in wide and maintains a constant speed of 0.5 in/min, giving 24 hours recording time from one roll of paper, which incidentally has an indefinite shelf life.

The four MIMCO "Contour" recorders shown in the illustration are installed aboard Shell's *Philine* tanker giving fore, aft and two amidships depth soundings, in order to obtain a clearer picture of hull clearance in very shallow water. The recorders operate simultaneously down to 18 in at 100 soundings/min and a resolution of 0.2 in/ft. A sounding taken on board the *Philine* as she approaches one of her berths is illustrated below.

The address of the Marconi International Marine Co. Ltd. is Eletttra House, Westway, Chelmsford, Essex.

WW 301 for further details

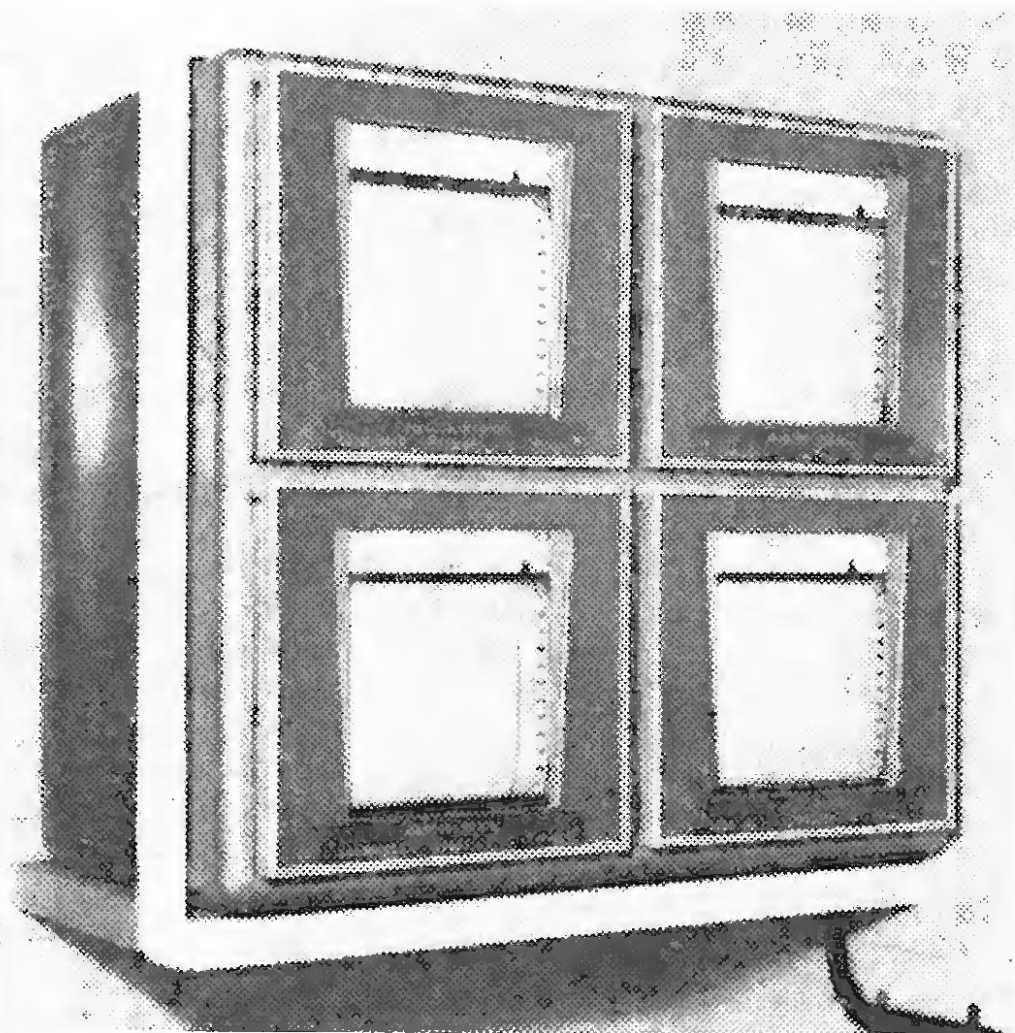
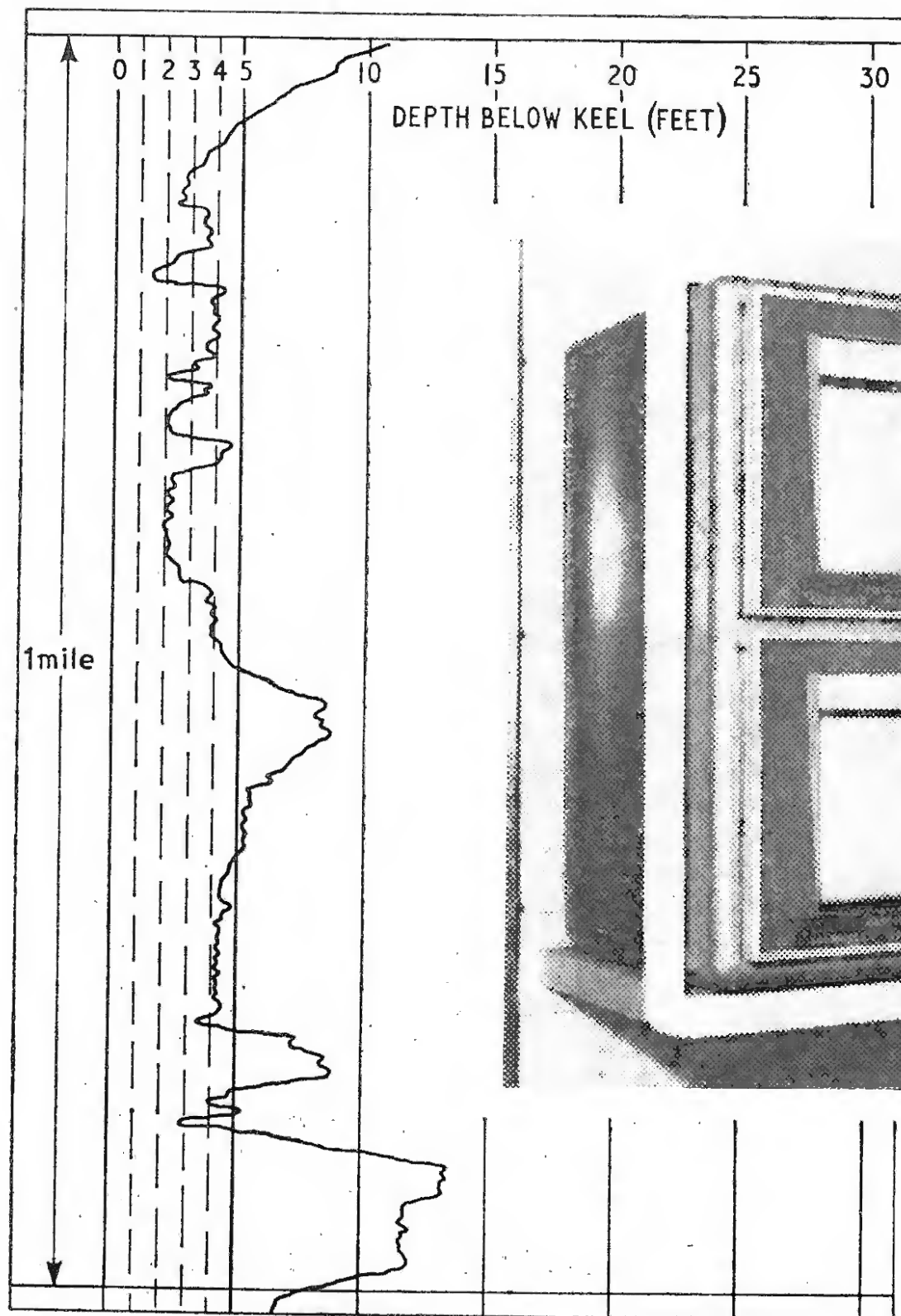

## equipment systems components

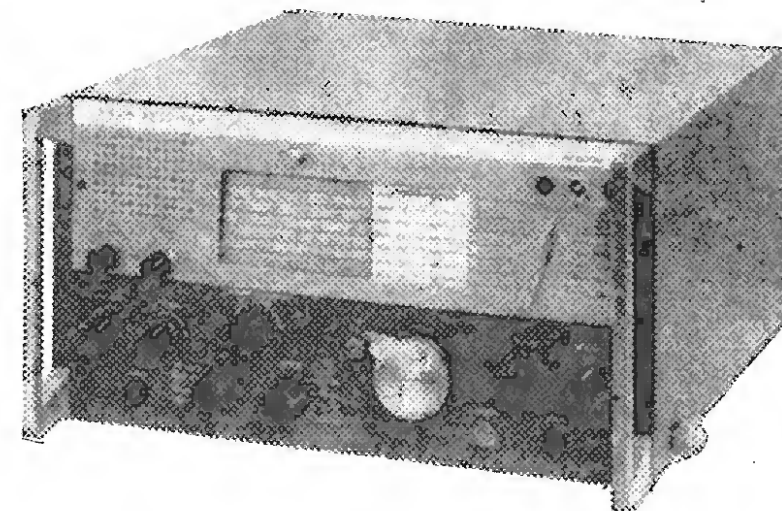

## COMMUNICATIONS RECEIVER

DESIGNED for general purpose telephony, telegraphy and facsimile reception in the 13 kc/s to 28 Mc/s range is the R408 communications receiver from Redifon Ltd., of Broomhill Road, London, S.W.18. Transistors are used throughout this set, which has been type approved by the G.P.O. and is suitable for marine use. Fourteen switched ranges are provided to give continuous coverage and an extra position is included on the waveband switch to bring in the pre-tuned 500 kc/s marine distress and calling frequency.

For frequencies below 650 kc/s, the intermediate frequency is 80 kc/s and above this double conversion is employed. While the second i.f. remains constant at 80 kc/s, the first changes as the signal frequency increases; starting at 470 kc/s, then 1.5 Mc/s and finishing at 4.5 Mc/s. The modes of operation include a.m., c.w., s.s.b. (pilot or suppressed carrier) and i.s.b. (switch selection of upper or lower sidebands).

A feature of the R408 is that the a.g.c. system is selectable, with delay times of up to 10 seconds and attack times of up to 5 milliseconds. Minimum times are 1 second and 100 msec respectively. Another feature is continuously variable bandwidth, from 800 c/s to 8 kc/s for a.m. and c.w. working and from 800 c/s to 4 kc/s on s.s.b. For c.w. the bandwidth can be narrowed by means of a crystal filter which reduces it to 160 c/s. Audio, line i.f. and a.g.c. outputs are provided.

The standard R408 will operate from either 100/125 or 200/250 volt a.c. (50/60 c/s) supplies. Also available is a version for 24 volt d.c. operation, and an adaptor to allow this version to be driven from either 110 volts or 220 volts d.c.

WW 302 for further details

## CRYOGENIC MICROWAVE CIRCULATOR

ABLE to operate at temperatures as low as that of liquid helium, the new cryogenic stripline circulator developed by the Marconi Company, of Chelmsford, should be of interest to those designing low-noise amplifiers for satellite receiving systems.

The circulator is a four-port device suitable for use in the frequency range 3.6 to 4.3 Gc/s with possibilities of use at even higher frequencies. It employs a ferrite material whose cryogenic properties are similar to those of normal ferrite at room temperature. Excellent results have been obtained from this material over a wide range of low temperatures, including liquid helium ( $-269^{\circ}\text{C}$ ) and liquid nitrogen ( $-196^{\circ}\text{C}$ ). It will also operate at room temperature at reduced performance. This feature is worth noting as the equipment may be tested before refrigeration, and of course operated at reduced performance should the refrigeration plant break down while in service.

WW 303 for further details

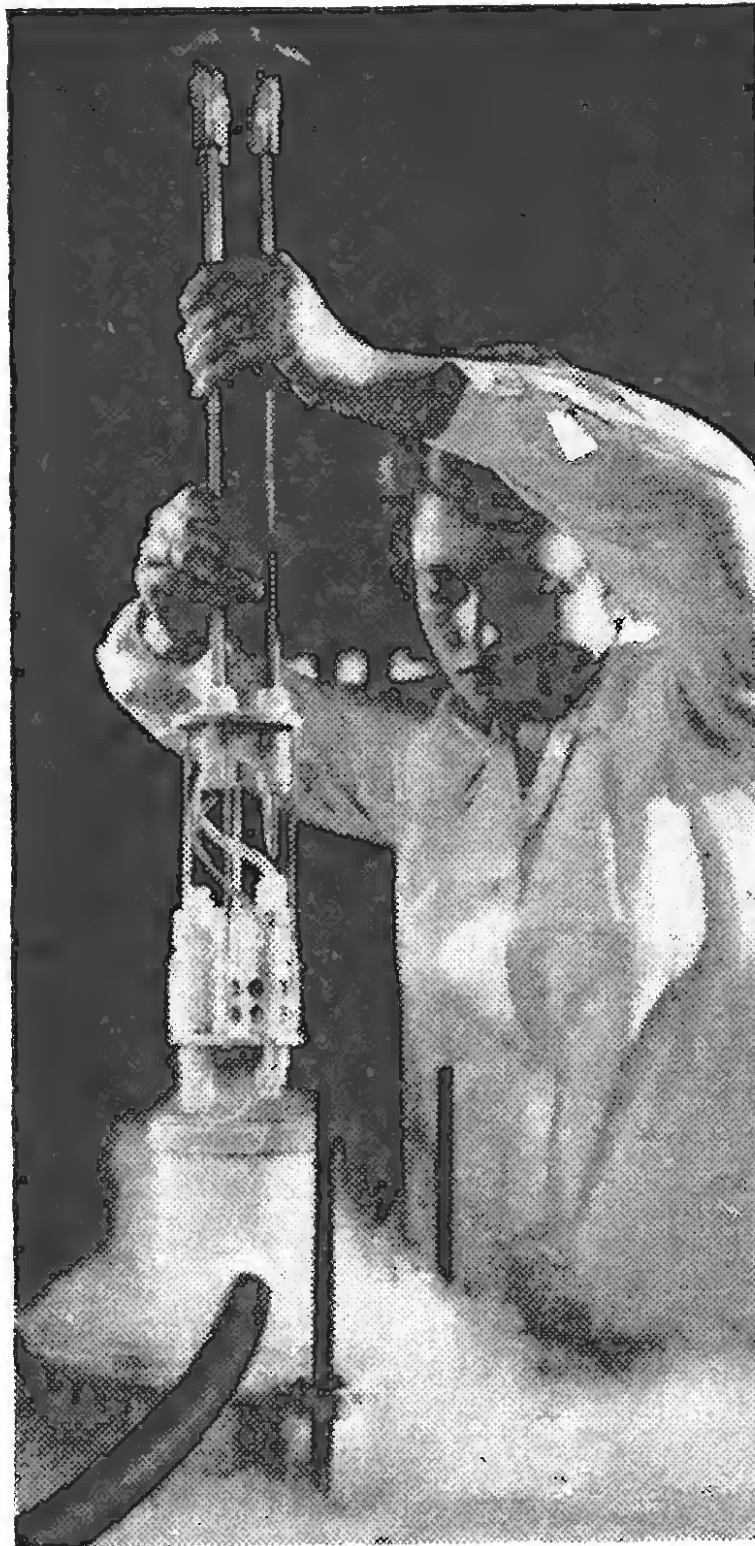

## Frequency to D.C. Converters

A RANGE of frequency detectors covering 0 to 50 c/s to 0 to 20 kc/s (nine different ranges, and units to cover higher frequencies to special order) is being offered by the Seminole Division of Airpax Electronics Incorporated, of Fort Lauderdale, Florida. These units, known as Magmeter detectors, provide a d.c. output directly proportional to input frequency and have a quoted accuracy of better than 0.25% on frequencies up to 100 kc/s. The standard output



is 0 to 1 mA into a  $325\Omega$  external load (internal output resistance is approximately 5 k $\Omega$ ).

Three different versions are available to cater for valve circuits and 12 or 24-volt transistor circuits. Each version is available in either an octal plug-in base or a "bolt-down"  $1\frac{1}{2} \times 1\frac{3}{4} \times \frac{1}{2}$  in case. The height of the octal unit is  $1\frac{1}{4}$  in.

WW 305 for further details

## AUTOMATIC WEATHER CHART RECORDER

ALTHOUGH designed for shipborne installations, the D-900-T series of automatic weather chart recorders made by Muirhead is also suitable for small airfields and airstrips. The recorder comprises a radio receiver, f.m./a.m. converter and facsimile unit.

Any eight of the many World Meteorological Organization's Radio-Fax transmissions in the frequency

range 1.5 to 25 Mc/s may be received once the pre-tuned r.f. units and crystals have been fitted. An adjustable beat frequency oscillator and a monitoring oscilloscope are incorporated to allow the operator to check that the correct frequency is being obtained (and maintained) from the f.s.k. transmissions.

The equipment is semi-automatic, the helix speed and index of co-operation (product of the drum diameter and number of lines per inch) being selected manually prior to recording. The equipment will then start and stop automatically on receipt of the appropriate W.M.O. control signals, but can be controlled manually by the operator if required. Recording is on standard 200 ft rolls of 9-in Mufax electro-sensitive paper.

Brief details from the specification include helix speeds of 60, 90 and 120 r.p.m.; scanning density of 98 or 196 lines/in; and power consumption of 100 watts. The D-900-T operates from 105/125 or 200/240 volt, 50/60 c/s supplies.

The address of Muirhead & Co. Ltd. is Beckenham, Kent.

WW 304 for further details

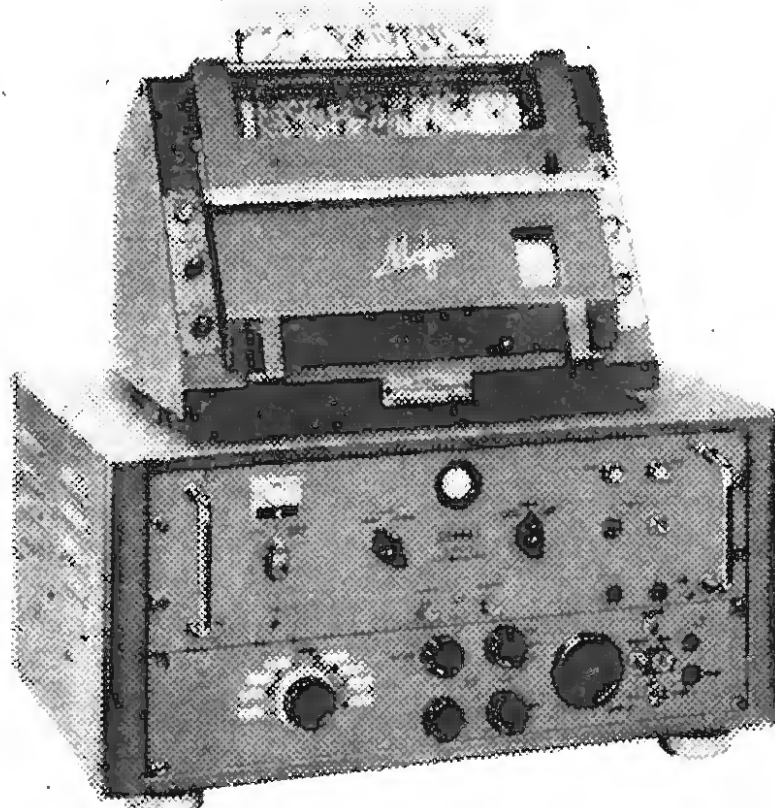

## D.C. Inverters

A RANGE of d.c. to a.c. inverters has been introduced by Synchro Developments (London) Ltd., of Dover Street, W.1. Known as the Porta Power range, it offers square wave outputs of 110, 240, 260 and 280 volts. Power ratings of 200, 500, 750 and 1,000 VA, are quoted for input voltages of 12, 24, 36 or 50 volts d.c. respectively.

Manual and automatic units are available, the latter incorporating self-operating changeover relays. The output frequency is within  $\pm 2\%$  of 50 c/s.

WW 306 for further details

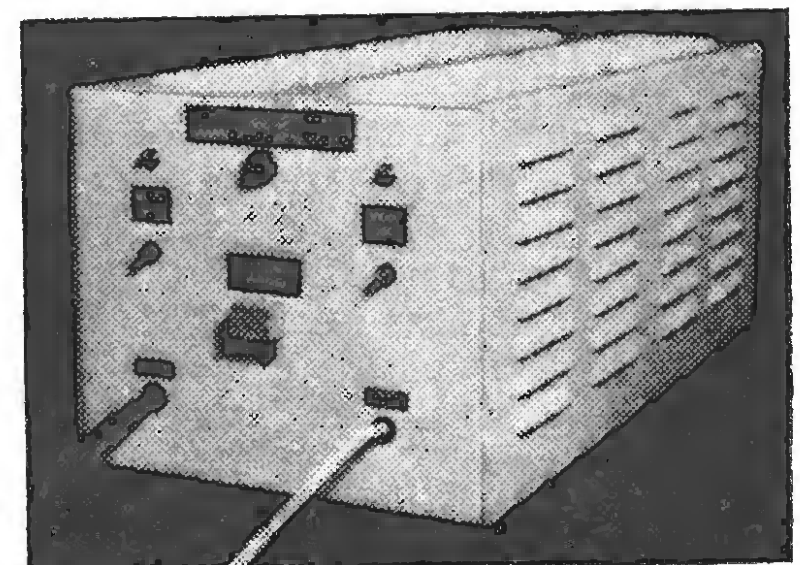

## Audio Response Unit

NINE separate controls are provided on the Astronic A1646 a.f. response unit from Associated Electronic Engineers Ltd. and allow the level of audio signals to be varied in octave steps (in multiples of two) from 40 to 10,240 c/s. Each of the nine controls is continuously variable and allows adjustment of +13 dB to -13 dB. On the standard model, the octave controls are illuminated and

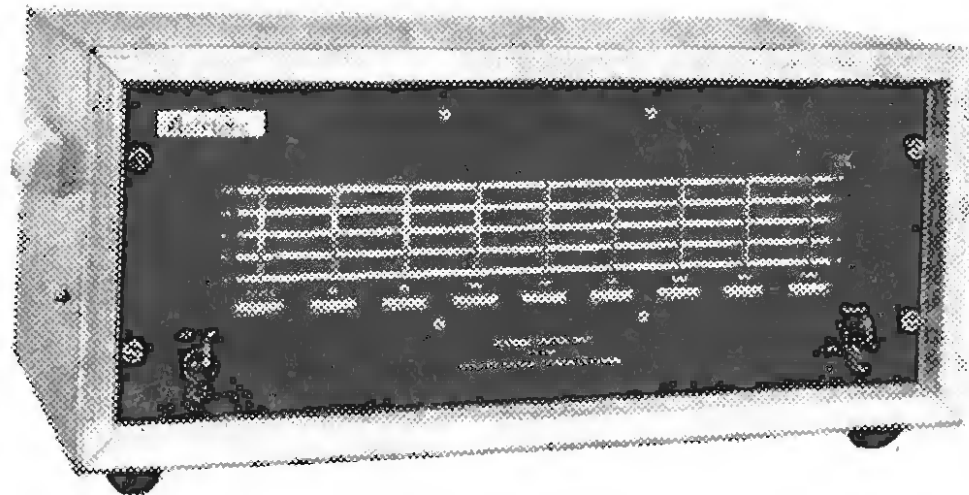

their settings are displayed in graphical form above the controls on the front panel.

At 0 dB level the input and output impedances are 600  $\Omega$ , with zero insertion loss. The overall response is within  $\pm 2$  dB from 20 c/s to 20 kc/s and the noise level is quoted as -60 dB. Overload level is +18 dBm. An "in-out" switch and an overall gain control is provided.

The standard model is housed in a metal case designed for bench use. Other models are available for rack mounting and with alternative input and output arrangements. The price of the standard model, the A1646, is £66. The company's address is Dalston Gardens, Stanmore, Middx.

WW 307 for further details

## GERMAN SOLID TANTALUM CAPACITORS

A RANGE of solid tantalum capacitors made by Standard Elektrik Lorenz, of West Germany, have recently been introduced into the United Kingdom by Standard Telephones and Cables Ltd., an associate company. The capacitance range offered is from 0.1 to 50  $\mu$ F, with working voltages from 3 to 35 V d.c. Capacitance tolerance is -20% to +50% and temperature range is from -40°C to +85°C.

The internal construction of the new series is similar to the established DEF 5134 patterns, but the capacitors are dipped in a moisture-resistant resin to give added mechanical protection. These capacitors are available from S.T.C.'s Capacitor Division, Brixham Road,

Paignton, Devon, or the London Sales Office, Footscray, Sidcup, Kent.

WW 308 for further details

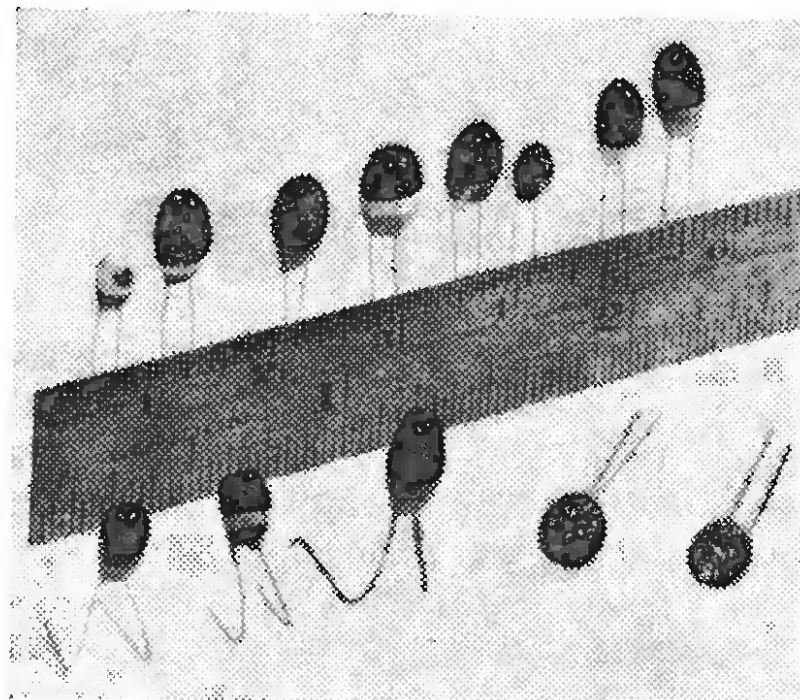

## PORTABLE DUAL-TRACE SCOPE

INTRODUCED primarily for the field service engineer of high-speed, solid state computers is the Type 453 dual-trace oscilloscope from Tektronix U.K. Ltd., of Beaverton House, Station Approach, Harpenden, Herts. This instrument has a 50 Mc/s bandwidth and uses a new Tektronix four-inch tube which provides the high writing rate and brightness required when used under high ambient light. Ten 0.8 cm divisions appear on the graticule.

Maximum dual-trace sensitivity is 20 mV/div at 50 Mc/s, 5 mV/div at 40 Mc/s, and the channels may be cascaded to obtain 1 mV sensitivity at 25

Mc/s, single-trace. Facilities are provided to delay signals for the viewing of the leading edge of the triggering waveform.

Horizontal deflection facilities include calibrated sweep delay, which is particularly useful when measuring pulse-to-pulse intervals, the amount of jitter on any train of pulses, time differences and phase angles. Calibrated sweeps extend from 5 sec/cm to 0.1  $\mu$ sec/cm, with a 10X magnifier extending the fastest sweep to 10 nsec/cm.

This instrument measures  $19 \times 10^3 \times 6\frac{3}{4}$  in and weighs 28 lb.

WW 309 for further details

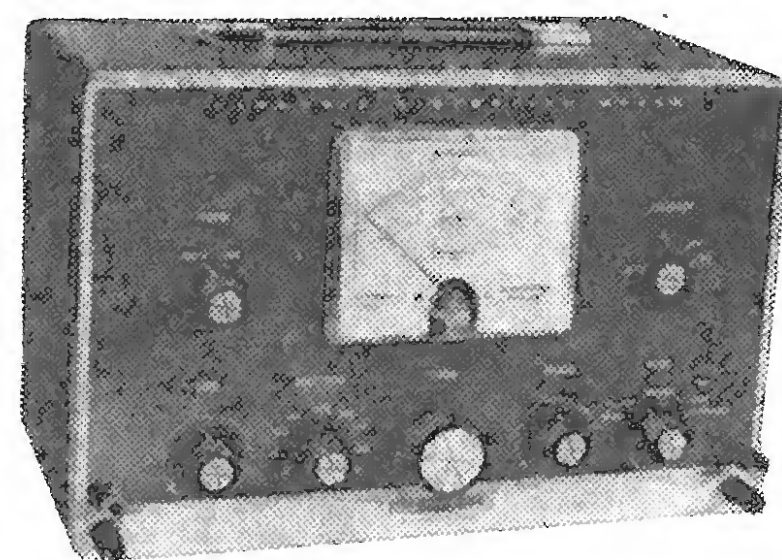

## Harmonic Distortion Meter

INCLUDED in the Model IM-12U harmonic distortion meter from Daystrom Ltd., of Gloucester, is a valve voltmeter section comprising a twin triode amplifier with negative feedback. It has four ranges from 0-1 to 0-30 volts.

The distortion meter has five ranges (0 to 1%, 3%, 10%, 30% and 100% full scale) and an accuracy of  $\pm 5\%$  plus 0.1%. The additional 0.1% is added to cover any hum, noise and distortion in the instrument itself.

The instrument indicates the residual components of the signal under test after the fundamental frequency has been removed as a percentage of the signal. In addition to harmonics, the residual signal contains any hum and noise present on the test signal at all frequencies in the audio range. The frequency coverage of the instrument is from 20 c/s to 20 kc/s, in three ranges.

This Heathkit instrument is available in kit form priced £24 15s. Assembled the price is £34.

WW 310 for further details

## Tantalum Electrolytics

THE "Castanet" range of tantalum electrolytic capacitors available from the dielectric and magnetic division of Plessey-UK Ltd., Towcester, Northants, has been extended by the introduction of the Type S which has specified impedance figures for capacitance values above 0.33  $\mu$ F, and is marketed in four case sizes A, B, C and D. Maximum impedance limits for the case sizes are, respectively:  $5 \Omega + X_c$ ;  $2 \Omega + X_c$ ;  $1 \Omega + X_c$  and  $0.5 \Omega + X_c$ , where  $X_c$  is the calculated reactance at 100 kc/s for the nominal capacitance value. It should be noted that the impedance limits obtained by the direct addition of the real and reactive terms comply with the requirements of the proposed S.B.A.C. specification for high-quality solid tantalum capacitors.

WW 311 for further details

## Low-Leakage Diodes

THREE new series Sylvania silicon-alloy diodes (D6623, D6624 and D6625) are being offered by Thorn-AEI Radio Valves and Tubes Ltd., of 155 Charing Cross Road, London, W.C.2. These diodes have been introduced for use in military and industrial computers and have very low current leakage characteristics—at a reverse voltage of 175 V, the D6625 measures 5 nA and the "A" version of this type only 1 nA. The first example shows an improvement of five times over currently available types and the latter 25 times.

Another feature of the new diodes, due to a new manufacturing process, is that they are suitable for high temperature work in general purpose applications.

WW 312 for further details

## Magnetic Switch

POWER handling of up to three amps at 120 volts is claimed for the new hermetically sealed magnetic switch developed by Sylvania Electric Products Incorporated, U.S.A. The normally closed contacts operate in a complete vacuum, making the unit suitable for use in places where arcing must not occur. Switch speed is quoted as 4 milliseconds and the operating temperature range from  $-54^{\circ}\text{C}$  to  $+200^{\circ}\text{C}$ .

The dimensions of the switch are  $1\frac{21}{32}$  in long by  $\frac{5}{16}$  in diameter. Any electromagnet with a minimum of 250 amp-turns will operate the switch, but the suggested reference magnet is Alnico V:  $1.25 \times 0.522 \times 0.158$  in.

These magnetic switches are available in the United Kingdom through Thorn Special Products Ltd., Great Cambridge Road, Enfield, Middx.

WW 313 for further details

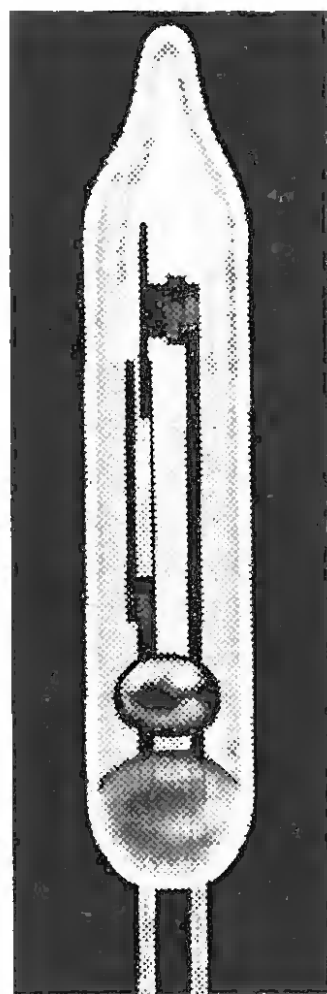

## TWO-PEN RECORDER

TWO pens independently controlled in the left-to-right direction and synchronized in the top-to-bottom axis are fitted to the x-y<sub>1</sub>-y<sub>2</sub> recorder Model 2FA

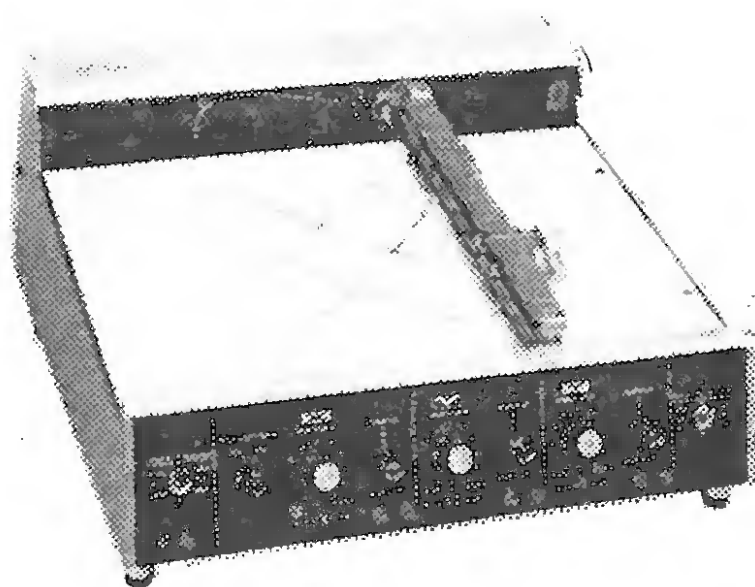

from the Moseley Division of the Hewlett-Packard, of Dallas Road, Bedford. This recorder is a bench-type instrument and has a plotting area of

11 by 17 in. There is a 0.1 in horizontal separation between the pens attached to the moving arm (seen in the illustration) to allow the pens to cross. An additional pen may be added to this instrument to produce identification marks at significant points in a recording.

Each axis of the 2FA has 11 calibrated d.c. input ranges with sensitivities from  $500 \mu\text{V}$  per inch to 50 volts per inch travel. The four most sensitive ranges may be converted for potentiometric input, should this facility be required. Input resistance on all calibrated ranges is  $1 \text{ M}\Omega$  at null point.

A five-range timebase is provided giving sweeps from 0.5 seconds per division to 50 seconds per division; which represents full sweep speeds of 7.5 to 750 seconds. An accuracy on all ranges of 2% is quoted for this instrument, which is priced at £1,293.

WW 314 for further details

## Portable Spot Welder

INTENDED for electronic and general laboratory applications the Electro-Magnetics "Porta-Weld" hand welding gun weighs less than  $2\frac{1}{2}$  lb. The gun contains an adjustable fingertip force control and a range of accessory tips is available. The resistance welding apparatus may be used to weld steel wire 0.002 in dia., 20 a.w.g. tinned copper or larger sizes of higher resistance metals. Energy is provided by charged capacitors and a joulemeter is incorporated to enable energy levels of

up to 100 joules to be pre-set.

Ni-Cd batteries may be used with the welder and will allow up to 1,000 welds, depending on welding time, without recharging. A recharging facility is provided on the standby function of the power supply unit. The power unit weighs 12 lb.

The welder is available from the Export Department of EMEC Inc. of 160 Terminal Drive, Plainview, Long Island, New York.

WW 315 for further details

## POLYESTER CAPACITORS

TWO new ranges of metallized polyester capacitors have been introduced by LEMCO. (London Electrical Manufacturing Co. Ltd., Bridges Place, Parsons Green Lane, London, S.W.6.) The ranges differ in size and finish, one being fully moulded and the other resin insulated. The moulded variety incorporate an anti-moisture trap in the capacitor base. Wire leads are solder coated and the capacitors stabilized by heat treatment.

A range of values based on the preferred logarithmic scale is available with standard tolerances of  $\pm 5\%$ ,  $\pm 10\%$  and  $\pm 20\%$  in values from  $0.01 \mu\text{F}$  to  $0.22 \mu\text{F}$ . Direct working voltage is 160 V and temperature range is  $-55^{\circ}\text{C}$  to  $+85^{\circ}\text{C}$ . At  $+20^{\circ}\text{C}$  the insulation

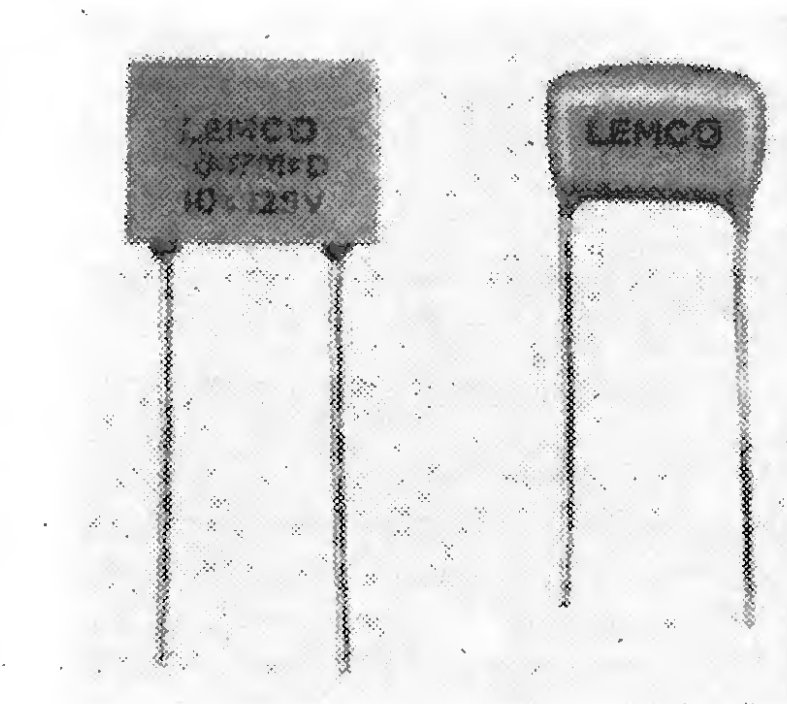

resistance is  $300 \text{ G}\Omega$  and the power factor at 1 kc/s is less than 0.0075.

WW 316 for further details

## INTEGRATED CIRCUIT HOLDER

SPECIALLY designed to accept integrated circuits in eight-lead TO-5 encapsulations is the Model S8 connector from Ferranti Ltd., of Kings Cross Road, Dundee, Scotland. Although primarily intended for use on printed circuit boards, this connector has been found particularly useful in prototype work where equipment is still under development.

The Model S8 connector is moulded

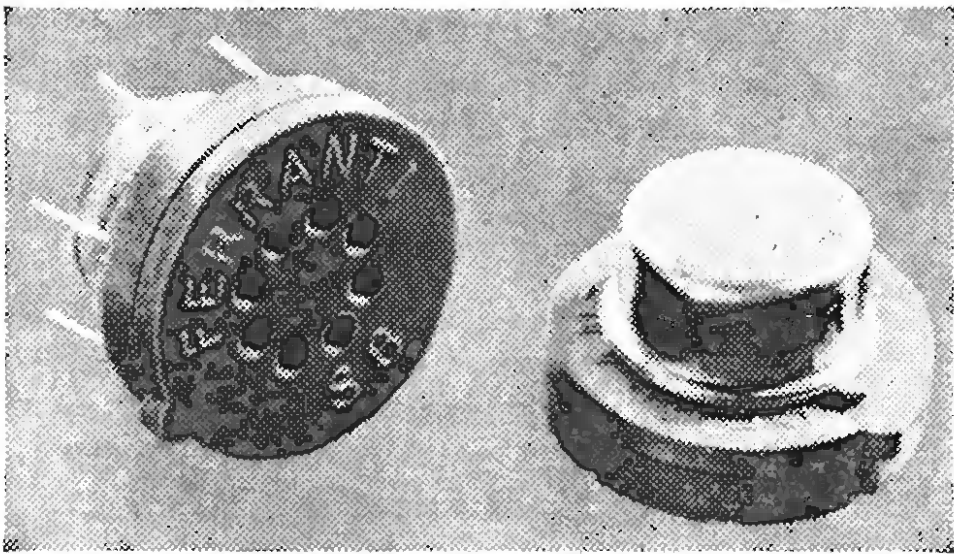

in glass-filled nylon and its eight beryllium copper contacts have a 0.0002 in ( $5\mu$ ) thick gold plating. To facilitate correct insertion, a projection is provided on the rim of the body of the connector to which the tongue of the TO-5 is aligned.

Contact resistance, including  $10\text{ m}\Omega$  contributed by the leads of the integrated circuit, is in the order of  $40\text{ m}\Omega$  and insulation resistance is quoted to be  $10\text{ kG}\Omega$ . Self inductance of each contact is  $0.001\ \mu\text{H}$  and capacitance between adjacent contacts is  $0.2\ \text{pF}$ . Insertion force is 600 gm and temperature range is  $-55^\circ\text{C}$  to  $+120^\circ\text{C}$ . The weight of the S8 connector is only 1 gm.

WW 317 for further details

## Thermal Wire Strippers

TWO new thermal wire strippers have been added to the Adamin range of soldering equipment produced by Light Soldering Developments Ltd., of 28 Sydenham Road, Croydon, Surrey.

Basically the two units are similar, but differ in wattage ratings. The Model 2B24 has a power consumption of approximately 50 watts and is specifically designed for p.t.f.e. work, while the Model 2B6 has a lower power rating and is suitable for use on p.v.c. and similar materials.

As can be seen from the illustration, the strippers can be operated by one hand. Two or three seconds should be allowed for the stripper to soften the covering to be removed. Heating is by means of an element in the shaft of each limb; directly beneath the blade unit.

Model 2B24 is available for 24 volts only and the Model 2B6 is suitable for operation from either 12 or 24 volts.

The price of the 2B24 is £3 15s and the 2B6 is £3 10s. Three step-down transformers are offered. The MT24 costs £3 15s and is suitable for both models; the LT12 and LT24 each cost £2 2s and are suitable for the 12 and 24 volt versions of the 2B6.

WW 318 for further details

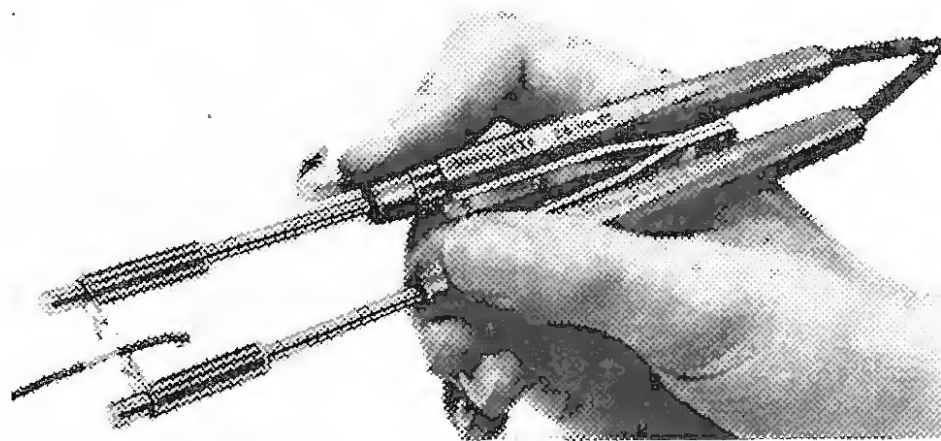

### INFORMATION SERVICE FOR PROFESSIONAL READERS

To expedite requests for further information on products appearing in the editorial and advertisement pages of *Wireless World* each month, a sheet of reader service cards is included in this issue. The cards will be found between advertisement pages 16 and 19.

We invite professional readers to make use of these cards for all inquiries dealing with specific products. Many editorial items and all advertisements are coded with a number, prefixed by WW, and it is then necessary only to enter the number(s) on the card.

Postage is free in the U.K. but cards must be stamped if posted overseas. This service will enable professional readers to obtain the additional information they require quickly and easily.

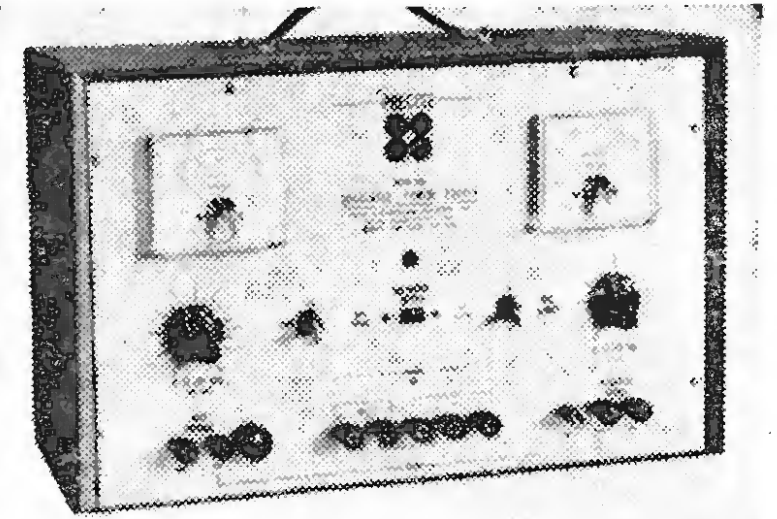

## POWER SUPPLY UNIT

A REGULATED power supply, designated Model 780, is available from Precise Electronics and Development Corp., Long Island, New York. This unit supplies two continuously variable direct regulated voltages of 0 to  $+400\text{ V}$  (ripple less than  $3\text{ mV r.m.s.}$ ) and 0 to  $-150\text{ V}$ . Output levels are set by the adjustment of two front-panel controls. A maximum current of  $2\text{ mA}$  can be drawn from the negative supply but load current from the positive supply is specified at half and full values of output voltage, i.e., at  $200\text{ V}$ , a continuous current of  $100\text{ mA}$  or intermittent current of  $150\text{ mA}$  is available; at  $400\text{ V}$  continuous current is  $150\text{ mA}$ . Regulation up to  $100\text{ mA}$  is better than  $0.3\%$  or  $0.3\text{ V}$  (whichever is greater). Two  $6.3\text{ V a.c.}$  supplies—one centre-tapped—rated at  $3\text{ A}$  each are also available and can be interconnected to provide either  $6.3\text{ V}$  at  $6\text{ A}$  or  $12.6\text{ V}$  at  $3\text{ A}$ . All output connections from the unit are made by terminals on the front panel, and voltage and current can be monitored on separate meters. The dimensions of the unit are  $9 \times 14\frac{1}{2} \times 7\frac{1}{2}\text{ in.}$

WW 319 for further details

## High-temperature Furnaces

VERTICAL high-temperature furnaces have been added to the Johnson, Matthey range of laboratory furnaces. There are eight models, four with a maximum temperature of  $1,350^\circ\text{C}$ , the remainder operating at temperatures up to  $1,500^\circ\text{C}$ . Four diameters of furnace are offered ranging from  $1\frac{1}{2}$  to  $2\frac{1}{2}\text{ in.}$

Each furnace has two thermocouples for use with a temperature controller and an over-temperature protection device. The thermocouples are embedded in the refractory, leaving the furnace chamber completely unobstructed. The overall dimensions vary according to model, the smallest being  $21\frac{3}{4} \times 12\frac{1}{8} \times 11\frac{1}{2}\text{ in.}$  and the largest being  $26\frac{3}{4} \times 18\frac{5}{8} \times 18\text{ in.}$  They all operate from a single phase  $105\text{ volt a.c.}$  supply.

Johnson, Matthey & Co. Ltd. are at 73-83 Hatton Garden, London, E.C.1.

WW 320 for further details



## Wideband Output Pentode

THE output capacitance of the special quality amplifier pentode EL5070 from Mullard's is only 2.9 pF. This represents a reduction in output capacitance of 25% on the E55L, upon which it is based.

The reduced output capacitance, which gives an improved gain-bandwidth product, has been achieved by redesigning the internal structure and using a top-cap anode connection instead of a base pin; as in the E55L. This feature has been found particularly useful when the valve is used in oscilloscope deflection

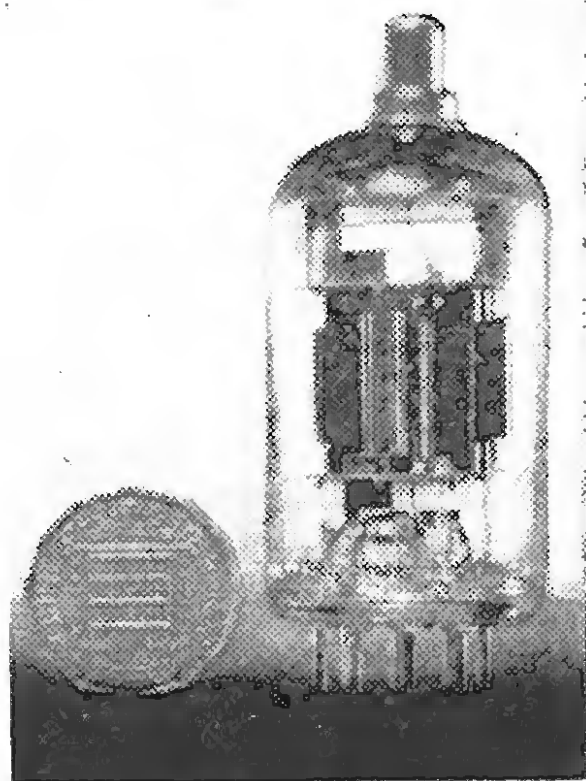

amplifiers as the lead between the anode and c.r.t. can be kept short resulting in an overall improvement in performance.

At an anode current of 50 mA, the mutual conductance of the EL5070 is 45 mA/V. This high slope has been obtained by using a frame-grid technique for both the control-grid and the screen-grid. Other characteristics of this valve include 10 W anode plate dissipation (maximum), anode voltage of 125 V and current of 50 mA, screen grid dissipation of 1.5 W (maximum), and a screen voltage of 125 V and current of 5.5 mA.

At present, the EL5070 is only available in sample quantities from Mullard House, Torrington Place, London, W.C.1.

WW 321 for further details

## Ultrasonic Generators

A SERIES of Soniclean automatic generators comprising Types 1190, 1192 and 1193 have now gone into production at Dawe Instruments Ltd. These supplement the Type 1191, which was announced in the March issue.

WW 322 for further details

## MICROWAVE MODULATION OF LIGHT

TWO microwave light modulators for coherent and incoherent light beams are now available from Sylvania International, a division of General Telephone and Electronics International S.A. of Switzerland. These are the SYO-4470 for modulation at S-band frequencies and the SYO-4460 (illustrated) for X-band frequencies. Modulators for L-band and C-band frequencies have been available for some time.

The linear electro-optic effect in a potassium dihydrogen phosphate (KDP) crystal bar is utilized in these units. An electric field applied parallel to the long optical axis varies the indices of refraction for axes 45° either side of the perpendicular. The electrical field is developed within a cylindrical microwave cavity, along the centre of which is suspended the KDP crystal. Adjustable input and output light polarizers and a quarterwave plate are built into the modulators. Through setting these in different combinations it is possible to amplitude, frequency or phase modulate light beams. It is also pos-

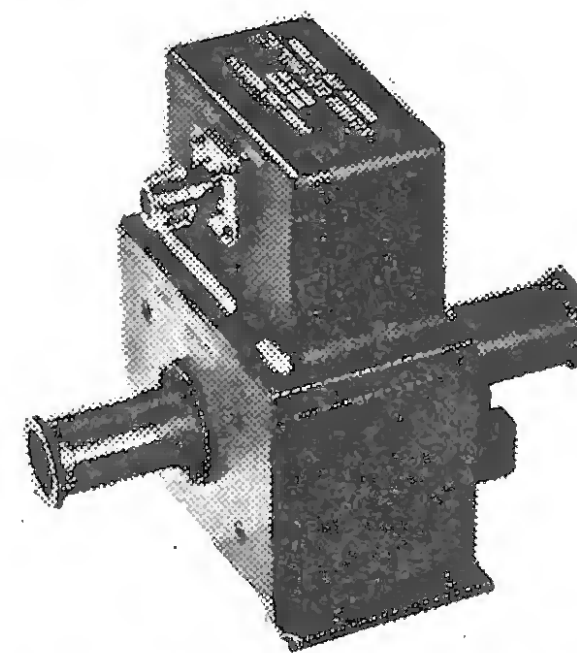

sible, after modification, to adapt for s.s.b.

Used in conjunction with the Sylvania series of microwave photo-travelling-wave tubes for the detection of modulated light, it is possible to build a complete microwave communications system with laser light as the transmission medium.

The address of Sylvania International is 21 rue du Rhône, Geneva, Switzerland.

WW 323 for further details

## A.C. to D.C. Converter

CONVERTING a.c. voltages linearly into d.c. voltages, the Model 710A from Ballantine Laboratories, of Boonton, U.S.A., should be of interest to owners of digital voltmeters. This instrument will accept a.c. voltages from 1 mV to 1 kV (in decade steps) at any frequency between 30 c/s and 250 kc/s. Accuracy of conversion is claimed to be better than 0.25% from 1 mV to 250 V at mid-band frequencies (50 c/s to 10 kc/s). Accuracy deteriorates to 1.25% as the frequency band increases and voltage increases (250 to 1,000 V).

The d.c. output, which varies from 1

to 10 volts, is proportional to the average value of the input waveform for sine waves and distorted waveforms with up to 30% total distortion, and has an impedance of approximately 25 kΩ. Input impedance is 2 MΩ shunted by 15 pF, except on the 1 mV to 10 mV range where the shunt capacitance is 25 pF.

Priced at £230 excluding duty, the Model 710A is available in the United Kingdom through Livingston Laboratories Ltd., of 31 Camden Road, London, N.W.1.

WW 324 for further details

## FLEXIBLE MULTIWAY CABLE

ABOUT the thickness of a postcard, the new flexible multiway cable called Biccastrip, consists of flat rectangular conductors positioned side by side and hermetically sealed in polyester resin insulation.

A range of screened, semi-screened and unscreened cables is now available from British Insulated Callender's Cables Ltd., of 21 Bloomsbury Street, London, W.C.1. The screened versions of Biccastrip employ rolled copper foil embedded in insulation above and below the main conductors with earth con-

tinuity conductors at the sides in contact with the foil (as can be seen in the illustration). The foil is on one side only of semi-screened cables.

WW 325 for further details

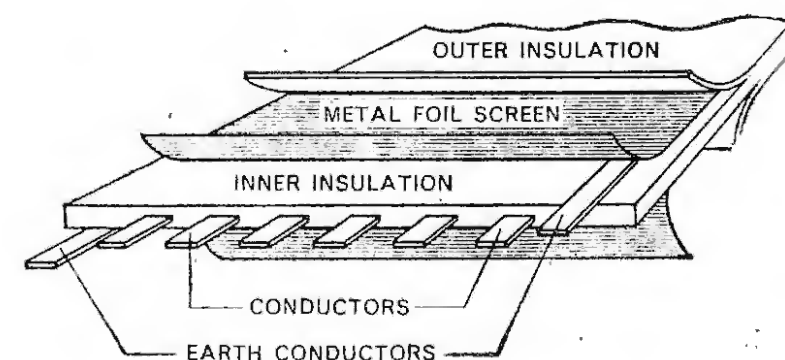

## "Science appears as what in truth she is

EACH of us, I suppose, has a pet hobby-horse upon which he is wont to ride at the slightest excuse, or even with no excuse at all. As a rather way-out instance of this, a friend of mine is absolutely convinced that there is a correlation between the taking of baths and scientific inspiration. He says that ever since the day when Archimedes sprang starkers from his tub and hared through the assembled populace yelling "Excelsior!" (or whatever it was) the bath has been the traditional home of deep thinking.

He (my friend, not Archimedes) has not been content to let the matter rest within the realm of mere opinion. He has prepared graphs which he believes prove his point. One curve, plotted through from pre-Roman times to the end of the nineteenth century, shows the vicissitudes of the bath-taking habit over the centuries, while a second, drawn to the same time-scale, purports to give the fat and the lean periods of discovery in science. My friend is not too specific as to how his data are prepared, but I do know that prolonged periods at the British Museum and much intricate work with a slide rule are essential adjuncts—and these are two institutions with which one does not argue lightly. And, although I am not wholly convinced of the validity of the comparison, common fairness compels me to admit that the two graphs follow astonishingly parallel paths.

They clearly prove (asserts my friend) that it was the Roman addiction to baths which made them so great as engineers and so clever at conquering countries. And he points with pride to where both curves take a sharp dip at the period when the legions got thoroughly fed-up with the British climate and pulled out. Between that time and the sixteenth century the troughs are deep indeed; then both tend to rise until they reach the maxima toward the end of the nineteenth century.

### "Sought out many inventions"

Naturally, I have pointed out that the Victorians were not noted for their fondness for baths, but he believes that he has the answer to that one. His researches have shown, he says, that in those days the young, instead of being permitted to chew Purple Hearts and tomcat around the territory on motor-scooters, were religiously dunked in cold tubs by their elders (and at very frequent intervals, too) in order to subdue the desires of the flesh. The net result was that at every available opportunity the young Victorians would dash off to the potting shed and invent things right, left and centre. They had to do something or burst. Or so my friend says.

I mention all this because it is relevant to the desperate predicament in which I now find myself. My statistically minded acquaintance is anxious to bring his graphs up to date as a prelude to delivering a learned paper upon the matter and he recently bludgeoned me into gathering data relating to the major electronic inventions of this century.

Now at the time of this coercion I must admit that neither of us had any doubts regarding the outcome, knowing as we did that (a) there are now far more bathrooms to the square rod, pole or perch than ever before and that (b) we are

Not as our glory and our absolute boast,  
But as a succedaneum and a prop  
To our infirmity."

*The Prelude; Wm. Wordsworth*

spending more millions of pounds on electrical research this century than our ancestors spent shillings during the previous nineteen. My *modus operandi* was simple and, I thought, foolproof. I merely sat down and made a note of the master inventions which we are accustomed to regard as of recent, or at least, of twentieth century origin, fully expecting to find the majority clustering in the period from 1939 onward when the research effort began to wax and grow exceeding fat. Alas! What a great setting forth on little horses!

### Red herrings!

Sound broadcasting gave me my first jolt, for the first broadcast of speech and music occurred, not around 1920 as I was positive it had, but as long ago as 1906.

Television served me no better; the mechanical system, which consistently made the headlines as the marvel of the age in the 1920s and early 1930s, was, I discovered, invented in 1884, while the all-electronic system in use today was conceived by Campbell-Swinton in its essentials in 1908.

What is now known as radar was born in 1935. But Hertz was using centimetric waves in 1888 and was demonstrating that they could be reflected and refracted.

The cathode-ray tube in its present high-vacuum form dates from 1929, but the instrument was invented in 1897, nine years before the thermionic triode.

The semiconductor properties of certain metallic sulphides were demonstrated in 1874. Semiconductor diodes have, I found, been in use since 1906. Oscillating crystals, suspiciously like tunnel diodes, date from 1911. (In 1924-25 interest was resurrected in these and W.W. ran several articles dealing with the subject.)

The transistor is generally supposed to have been invented in 1948, but a cutting now in front of me—for which I am indebted to reader E.R.H. of Blackpool—gives details of what seems to be an n-p-n transistor which was patented in Canada in 1925.

The optical maser arrived in 1960 (Hurray! Success at last!) The snag is that the principle underlying the stimulated emission of radiation was stated by Einstein in 1917.

The transmission of telephony along a light beam goes back, I find, to 1878, when Graham Bell and Sumner Tainter not only took out patents and successfully demonstrated it, but in addition, are stated to have shown 49 other possible ways of doing it.

There were, I regret to say, many other similar red herrings; for example, facsimile transmission, and the tape recorder. I abandoned the former when I got back to a reference in 1847 and the latter when I discovered that it was one of the hits of the Paris Exhibition of 1900.

So, to cut a long story short, the 1965 end of my graph, apart from the innovation of integrated circuits, has little or no representation at all; it has taken an aversion to its companion curve in no uncertain manner, drooping woefully where it had been expected to climb.

You can see, I hope, something of the devilish situation in

which I have unwittingly landed myself. My friend—or, more correctly, my erstwhile friend—has laid the blame entirely at my door, charging me with *suppressio veri*, malice aforethought and grievous bodily harm to his precious theory. I hasten to make clear, however, that I am not nearly so much concerned with the dissolution of the bathtub hypothesis as with the thought that I have inadvertently let the side down by exposing modern electronics research to the charge that it has bred a race of improvers rather than originators.

### Re-search or invention ?

In my less despondent moments I try to tell myself that research means re-search, and this is precisely what it is doing with success if one compares, for instance, the performance of the original Braun c.r.t. with its modern counterpart. But, lucrative as it has been to pick over the scrap-heap, the time must come when everything valuable has been removed, and then what? Research laboratories are as the sand on the seashore for multitude but does anyone know of the existence of an Invention laboratory?

In the hope of disproving my findings, my sometime friend has carried out an investigation of his own into other branches of engineering with, it seems, not dissimilar results. He is now, I understand, trying to reconcile his wretched graphs on the Mohammed and the mountain principle by seeking to introduce a corresponding downward trend in his ablutionary curve. To this end he is investigating three possibilities, namely (a) that modern bathrooms are merely status symbols, not to be sullied by usage, (b) that impurities in the Victorian water supplies, like impurities in semiconductors, were responsible for making the whole thing work, or (c) that the secret lies in temperature difference, remembering the effete modern predilection for the hot bath in contrast to the spartan Victorian cold tub.

I can only say that (a) is a hypothesis that I personally would refuse to countenance at any price. If (b) is the solution, then it should be a fairly simple matter to restore the status quo by introducing the requisite number of tadpoles and other foreign bodies into the water mains.

My money, however, is on (c) which I consider holds fascinating possibilities. If this is indeed the correct answer, then we may well be on the brink of a major breakthrough in the field of significant invention. By cooling our leading scientists to liquid helium temperatures they should respond Maser-fashion to the treatment, with their respective signal-to-noise ratios improved out of all recognition.

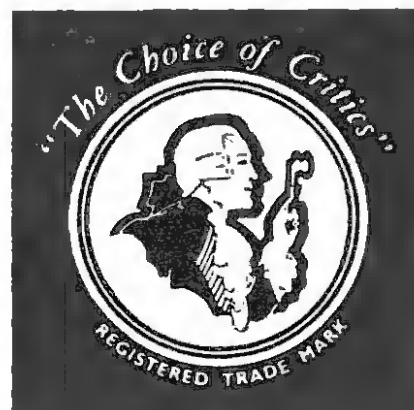

## THE HOUSE OF BULGIN AT YOUR SERVICE

### SINGLE-POLE NEON FUSE-HOLDER

WHEN IT  
BLOWS

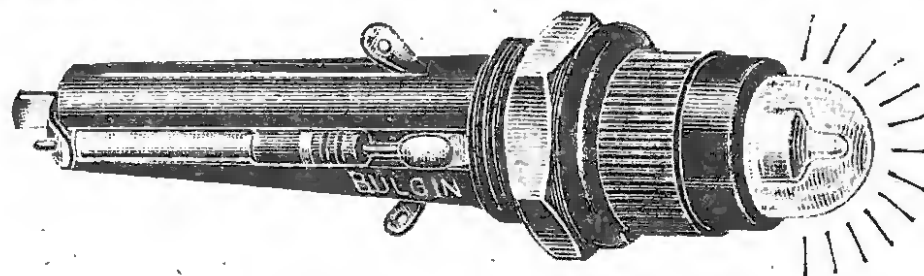

IT  
GLOWS

List No. D.F.826/V

Users of this model will find it invaluable in cases where *time means money*. When the fuse "blows," a neon lamp instantly "glows" enabling immediate location. Accepts  $1\frac{1}{4} \times \frac{1}{4}$  in. fuses and can be used on mains of 100/125 V. or 200/250 V.

U.K. Pat. No. 930330, U.S.A. Pat. No. 1,132, 224.

### OTHER POPULAR FUSE-HOLDERS

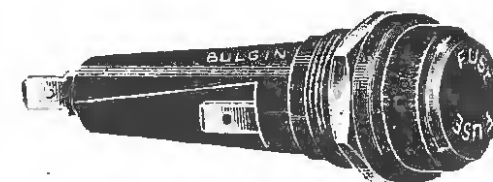
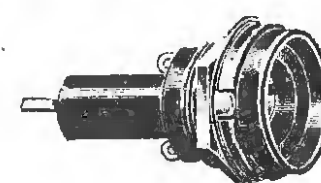
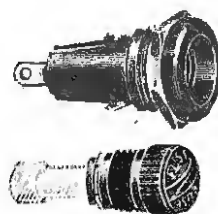

List Nos. F.296 & 297

List No. F.55

List Nos. F.155 & 156

List No. F.315

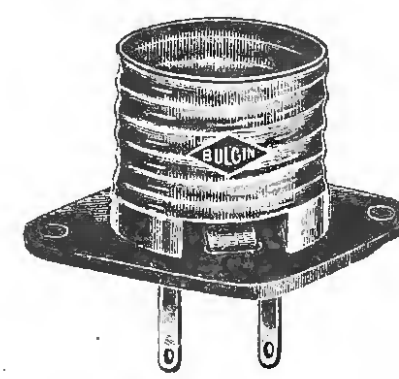
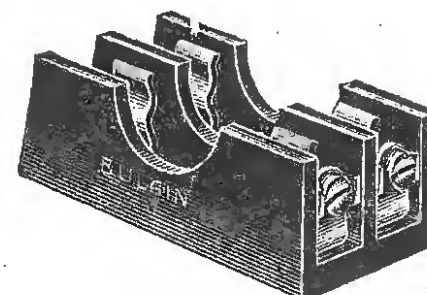
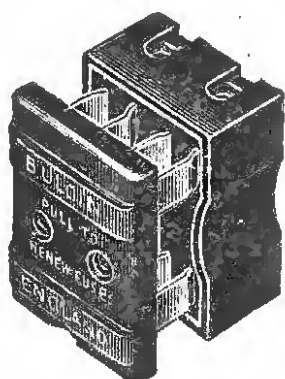

List No. F.119

List No. F.141

List No. E.S.2

A small selection is shown here from our large range of fuse-holders. Four panel-mounting types are illustrated in the top row including our new model, List No. F.315. The others are open and covered moulded fuse-holders for base mounting, together with List No. E.S.2 from our range accepting Edison screw fuses. Many different sizes of fuse are accepted by these models.

### FUSES TO FIT ABOVE HOLDERS



List No. F.120

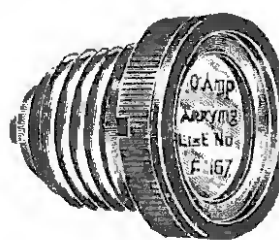

List No. F.160



List No. F.100



List No. F.286



List No. F.283/Rating



List No. F.90



List No. F.300/Rating

Illustrated above are seven models from our fully comprehensive range of fuses. These extend from normal mains-voltage fuses to delay fuses blowing on sustained overload, all available in many different sizes and ratings. Other types in our range include sub-miniature fuses for printed circuits, etc., and Edison screw types, shown by List No. F.160.

FOR FULL DETAILS SEE CATALOGUE 204/C

**A. F. BULGIN & CO. LTD.,**  
Bye Pass Rd., Barking, Essex.  
Tel: RIPpleway 5588 (12 lines)

MANUFACTURERS AND SUPPLIERS OF RADIO  
AND ELECTRONIC COMPONENTS TO

ADMIRALTY	MINISTRY OF WORKS	B.B.C.
WAR OFFICE	MINISTRY OF AVIATION	G.P.O.
AIR MINISTRY	MINISTRY OF SUPPLY	I.T.A.
HOME OFFICE	RESEARCH ESTABLISHMENTS	N.P.L.
CROWN AGENTS	U.K.A.E.A.	D.S.I.R.

WW-121 FOR FURTHER DETAILS.

# COMMERCIAL LITERATURE

"Hi Fi-Stereo" is the title of a 34-page brochure Telefunken have issued on their audio equipment, which ranges from record players to loudspeaker systems. Copies are obtainable from the Welmecc Corporation, 27 Chancery Lane, London, W.C.2.

WW 326 for further details

A "Selection Guide for Motorola Silicon Annular Transistors" is now available from the United Kingdom stockists of Motorola Semiconductor Products:—Celdis Ltd., Trafford Road, Richfield Estate, Reading, Berks.

WW 327 for further details

Tape Recorder Maintenance Ltd. announce that their latest pre-packed spares catalogue is now available from 323 Kennington Road, London, S.E.11. It lists an assortment of fuses, plugs and sockets, connectors and drive belt sets.

WW 328 for further details

The latest catalogue and price list of Stemag potentiometers (Berlin) has been received from F. W. O. Bauch Ltd. of "Chaddlewood," Cockfosters Road, Cockfosters, Barnet, Herts. The 1965/66 edition outlines in 16 pages the complete range of potentiometers and variable resistors, which includes miniature, twin, ceramic, button-type and printed circuit potentiometers. Details of the available track-laws, power ratings, tolerances, dimensions and other relevant information are given.

WW 329 for further details

Also available from F. W. O. Bauch is a 16 page booklet describing Sonnenschein (Hessen) Dryfit dry accumulators and chargers. Characteristics of the range of batteries is presented along with six graphs.

WW 330 for further details

Three types of automatic code generators are described in Pamphlet 1428a obtainable from Barr and Stroud Ltd., of Caxton Street, Anniesland, Glasgow, W.3. These generators are capable of producing a short morse code message and of keying a radio transmitter.

WW 331 for further details

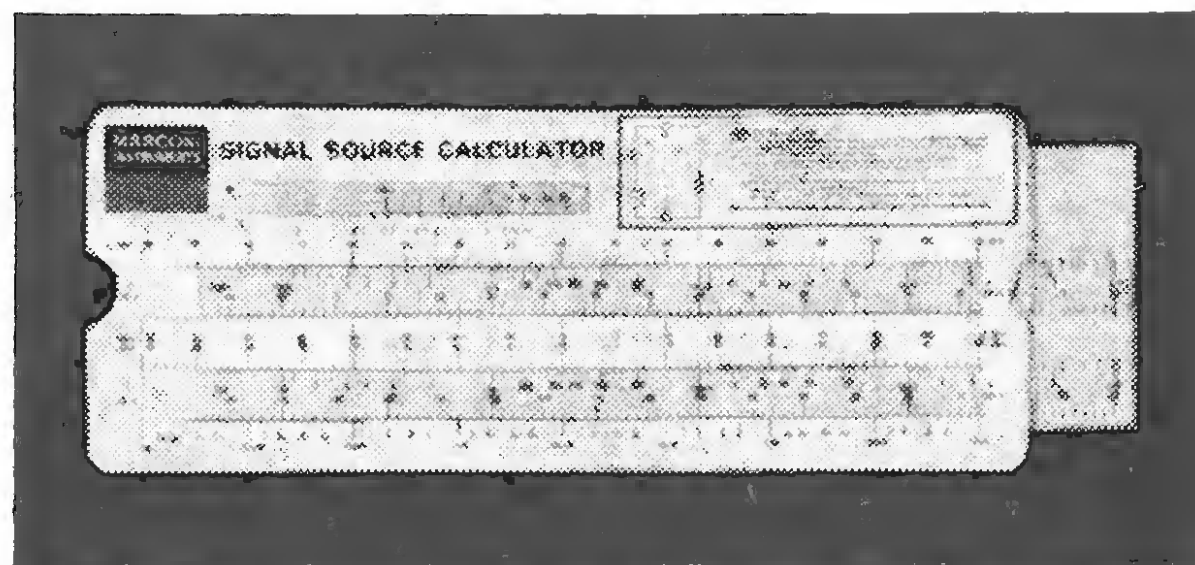

This signal source calculator is obtainable from Marconi Instruments Ltd., of St. Albans, Herts. Directions are given on the back for the conversion of volts to  $\text{dB}\mu\text{V}$  or  $\text{dBm}$  in a given load; watts to  $\text{dBm}$  or  $\text{dB}\mu\text{V}$  across a given load; volts to watts or  $\text{dB}\mu\text{V}$  to  $\text{dBm}$ ; and e.m.f. to p.d. across load.

WW 332 for further details

"Power Control for Industry" is the title of a Mullard catalogue covering thyristor and diode stacks and assemblies with d.c. outputs up to hundreds of kilowatts. Thermal performance of the Mullard range of heatsinks is also included in this 122-page publication, which is obtainable from the Industrial Markets Division, Mullard House, Torrington Place, London, W.C.1.

WW 333 for further details

Home Radio, of Mitcham, have revised and reprinted their "Components Catalogue." It now runs to 200 pages and contains information on a variety of components and equipment they stock. This ranges from aerials and audio amplifiers to volume controls and Zener diodes. Some 150 technical books are also listed in this publication which is available, price 7s 6d, from Home Radio (Mitcham) Ltd., 187 London Road, Mitcham, Surrey. The cost of the catalogue can be recovered on orders; at one shilling in the pound.

## H. F. PREDICTIONS — OCTOBER

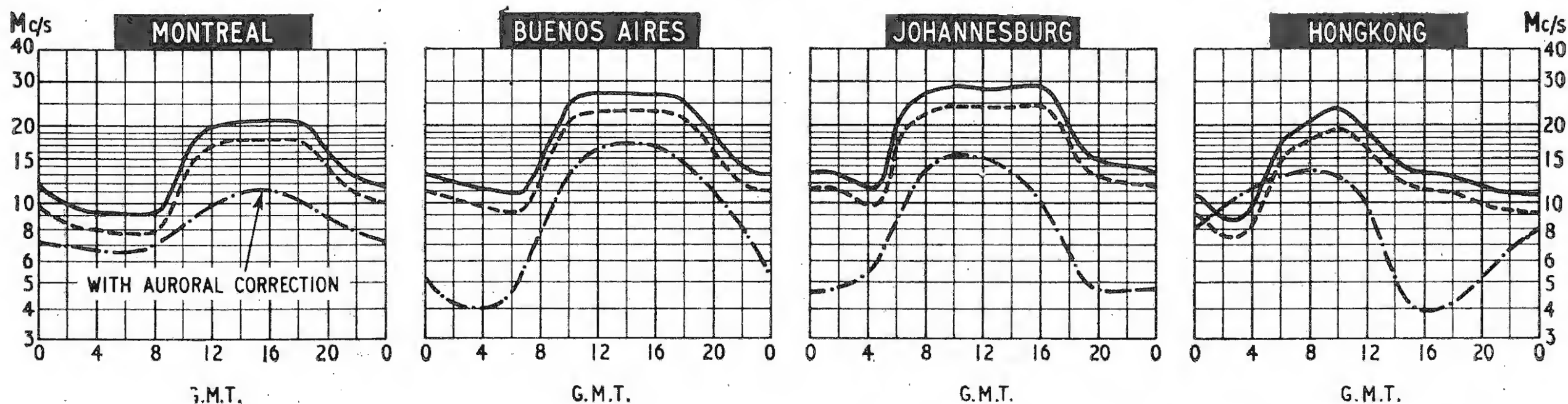

The effects of sporadic-E ionization are becoming less significant as winter conditions set in, and this month it is unlikely that sporadic-E will permit operation above the MUF. The seasonal changes in shape of the MUF curve is becoming apparent. The very flat curve of the summer months is slowly being replaced by the slightly higher, more peaky, curve characteristic of the winter months.

The prediction curves show the median standard MUF, optimum traffic frequency and the lowest usable frequency (LUF) for reception in this country. Unlike the standard MUF, the LUF is closely dependent upon such factors as

transmitter power, aerials, and the type of modulation. The LUF curves shown are those drawn by Cable and Wireless Ltd. for commercial telegraphy and assume the use of transmitter power of several kilowatts and rhombic type aerials.